



SPECIFICATIONS

CONTACT RATING: Dependent upon contact material.
MECHANICAL LIFE: 30,000 make-and-break cycles.
CONTACT RESISTANCE: 20mΩ max. initial @ 2-4VDC
 100mA for both silver and gold plated contacts.
INSULATION RESISTANCE: 1,000MΩ min.
DIELECTRIC STRENGTH: 1,000 V RMS@sea level.
OPERATING TEMPERATURE: -30°C to 85°C.

MATERIALS



CASE - Diallyl phthalate(DAP)(UL-94V-0)
ACTUATOR - Brass,chrome plated
BUSHING - Brass,nickel plated
HOUSING - Stainless Steel
SWITCH SUPPORT - Brass,tin plated.
TERMINALS/CONTACT - Brass, with Silver or gold plated. (See Page 31)

HOW TO ORDER

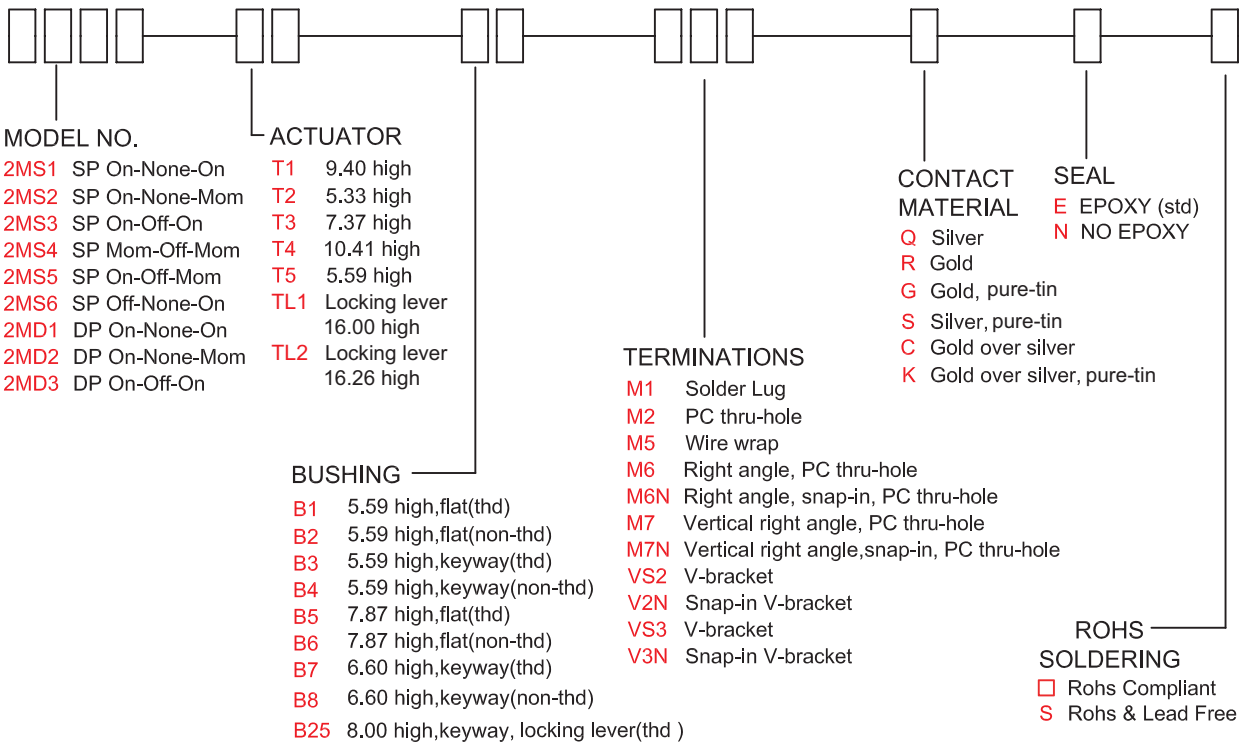
MODEL NO. ACTUATOR BUSHING TERMINATIONS CONTACT MATERIAL SEAL ROHS SOLDERING

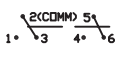
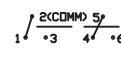

SWITCH FUNCTION

NO. POLES	UL/CSA MODEL NO.	MODEL NO.	SWITCH FUNCTION			CONNECTED TERMINALS / SCHEMATIC		
			POS.1	POS.2	POS.3	POS.1	POS.2	POS.3
SP	Q2211	2MS1	ON	NONE	ON	2-3	N/A	2-1
	Q2212	2MS2	ON	NONE	MOM			
	Q2213	2MS3	ON	OFF	ON			
	Q2214	2MS4	MOM	OFF	MOM			
	Q2215	2MS5	ON	OFF	MOM	OPEN	N/A	3-1
	Q2216	2MS6	OFF	NONE	ON			
DP	Q2221	2MD1	ON	NONE	ON	2-3,5-6	N/A	2-1,5-4
	Q2222	2MD2	ON	NONE	MOM			
	Q2223	2MD3	ON	OFF	ON			
	Q2226	2MD6	ON	ON	ON			

MOM=MOMENTARY

POLE OPTIONS



SPDT

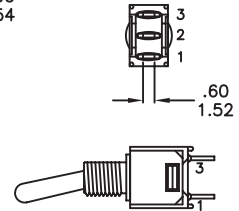
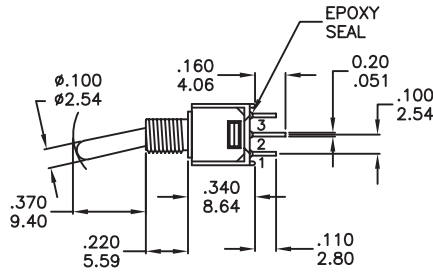
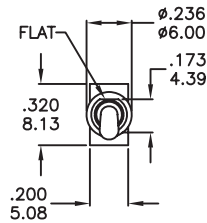

2MS6 Models : Omit 2nd terminal

Part No. Shown : 2MS1T1B1M1QE



DPDT

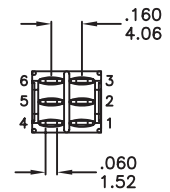
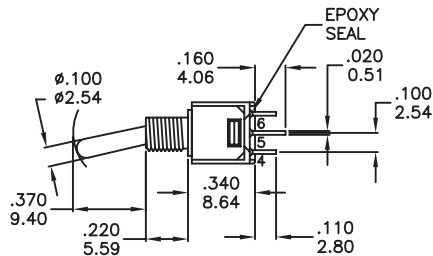
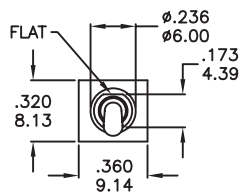

Part No. Shown : 2MD1T1B1M1RE

ACTUATOR FUNCTIONS

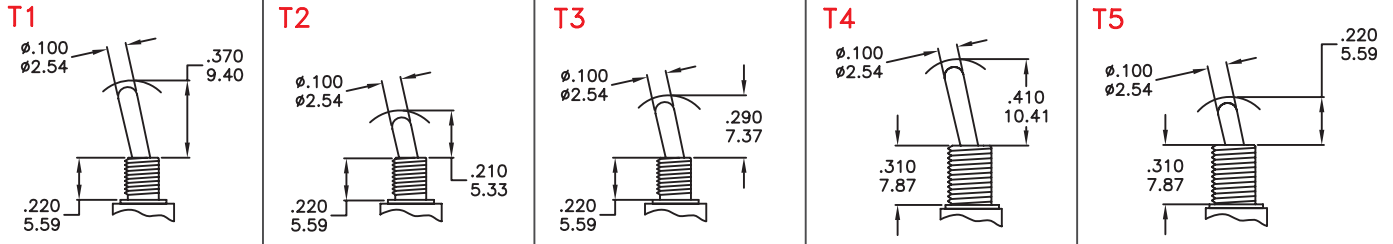

T1,T2,T3 Actuator shown with B1 to B4 bushing, subtract 0.09 (2.29) for B5 bushing, subtract 0.04(1.02) for B7 bushing.

T4,T5 Actuator shown with B5,B6 bushing, add 0.09 (2.29) for B1 to B3 bushing, add 0.05(1.27) for B7 bushing.

TL1B25

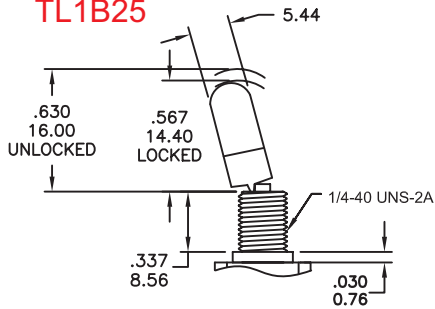

TL2B25

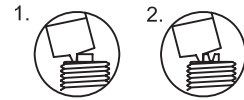
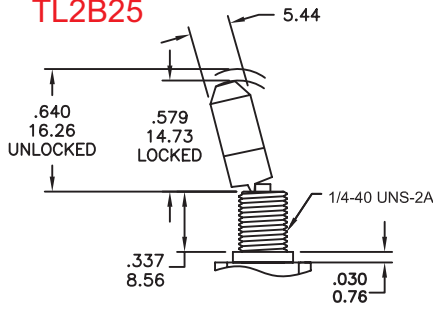

1. 2 positions lock
2. 3 positions lock

BUSHING OPTIONS

B1 THD B2 NON-THD

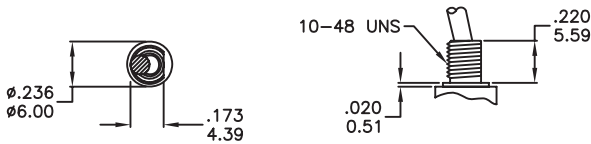

B3 THD B4 NON-THD

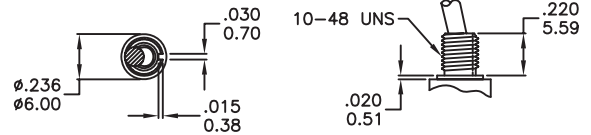

B5 THD B6 NON-THD

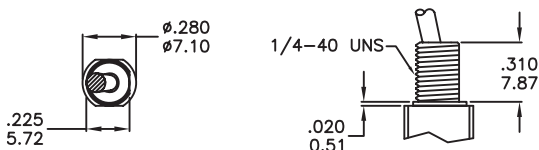

B7 THD B8 NON-THD

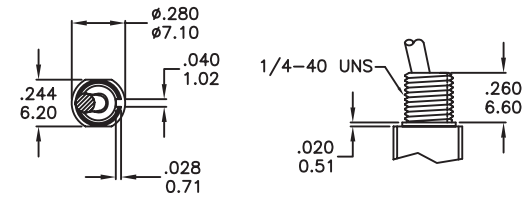

TERMINATION OPTIONS

M1

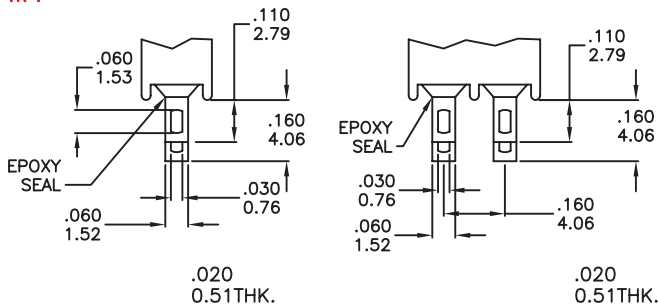

M2

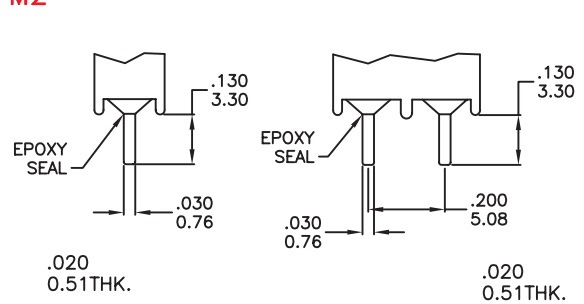

Double Pole

M6

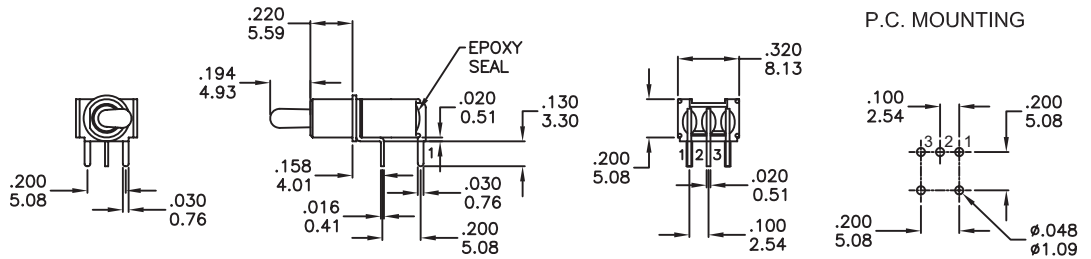
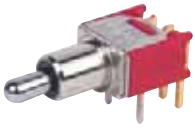

SPDT

Part No. Shown : 2MS1T2B2M6RE

M6

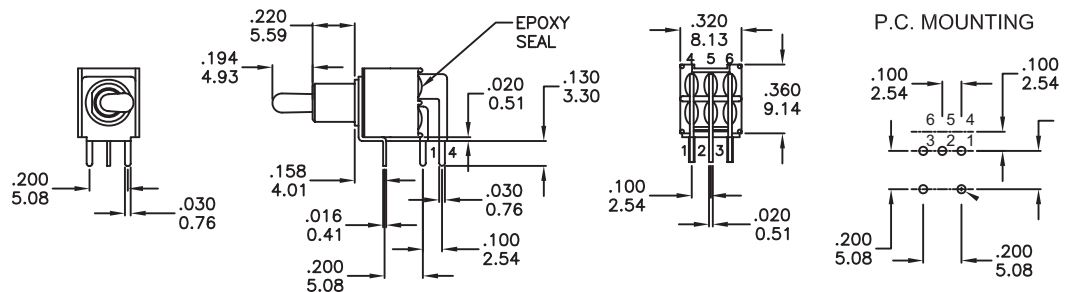
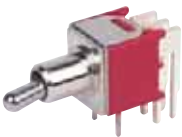

DPDT

Part No. Shown : 2MD1T2B2M6QE

M7

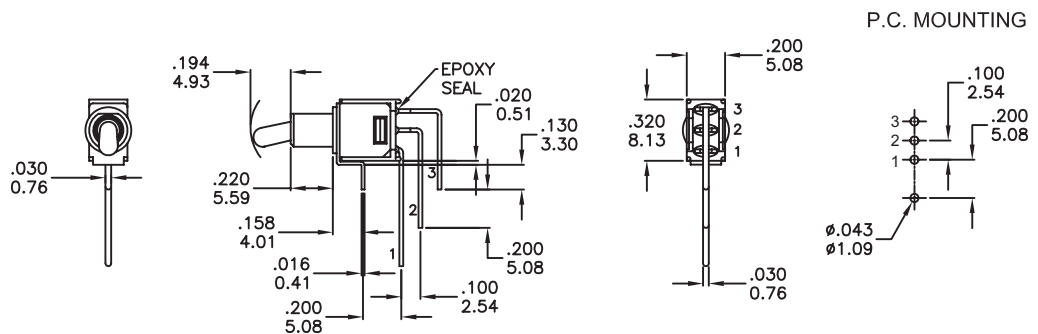
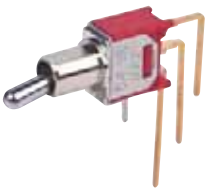

SPDT

Part No. Shown : 2MS1T2B2M7RE

M7

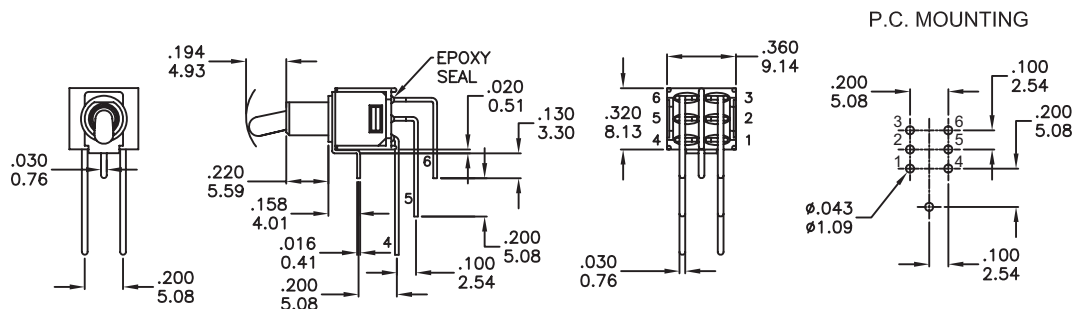
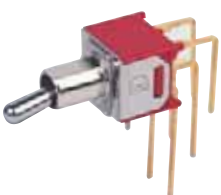

DPDT

Part No. Shown : 2MD1T2B2M7RE

2M Series

Sub-Miniature Toggle Switches

2M Sub-Miniature Toggle Switches

VS2 - VS3

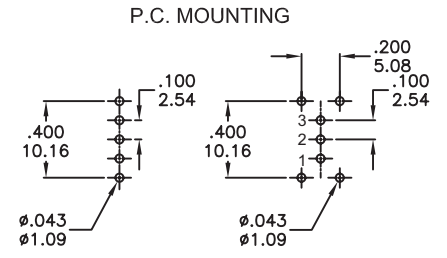
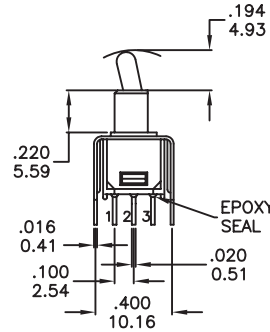
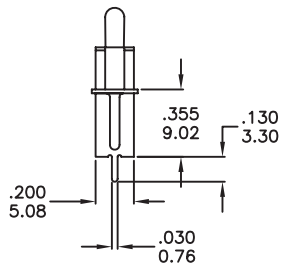

SPDT

Part No. Shown : 2MS1T2B2VS2QE

VS2

VS3

VS2 - VS3

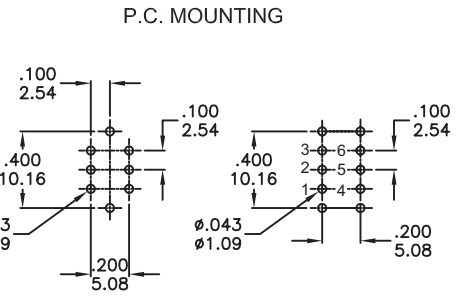
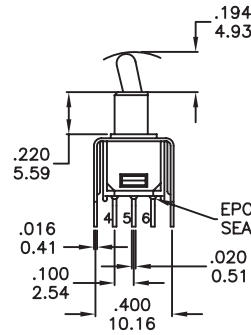
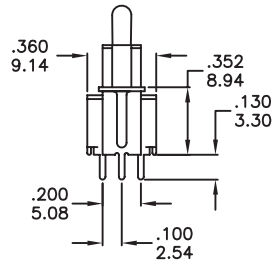

DPDT

Part No. Shown : 2MD1T2B2VS2QE

VS2

VS3

SNAP-IN TERMINATION OPTIONS

M6N

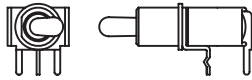

M7N

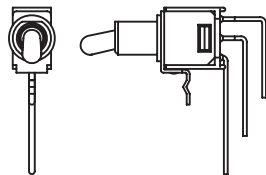

V2N

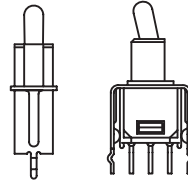

V3N

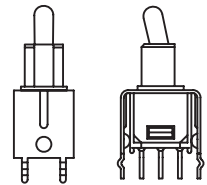

PANEL MOUNTING

10-48 BUSHING

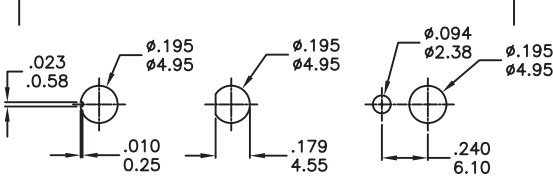

Without locking ring

With std. locking ring

1/4 IN. BUSHING

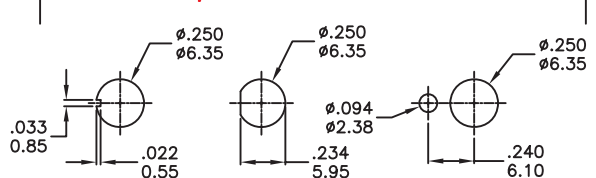

Without locking ring

With std. locking ring

HARDWARE

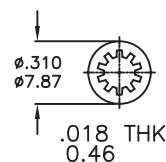
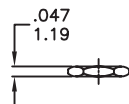
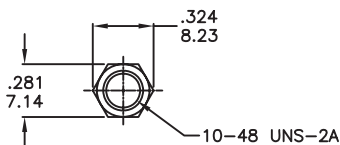

Locking Ring

CONTACT MATERIAL OPTIONS

	CONTACT MATERIAL	TERMINAL PLATING	RATINGS
Q	Silver	Q = Silver	3 Amps with resistant load @ 120VAC or 28VDC 1 Amps with resistant load @ 250VAC
S		S = Silver,pure - tin	
C	Gold over Silver	C = Gold over silver	
K		K = Gold over silver,pure - tin	
R	Gold	R = Gold	0.4 Volt-Amps(VA)max. @ 20V max. (AC or DC)
G		G = Gold,pure - tin	



SOLDERING PROCESSES

MANUAL SOLDERING : Use soldering iron of 30 watts, controlled at 350°C approximately 5 seconds while applying solder.

WAVE SOLDERING : Recommended Soldering Temperature:260±5°C
Duration of Solder Immersion: 5 ±1 seconds
(PCB is 1.6mm in thickness)

SOLDERING : Vapor phase

Temperature Profile

Zone	Room temperature	Time (Sec)
Pre-heat (A)	150°C	Min 120s
Soak (B)	180°C~200°C	Min 150s
Peak (C)	200°C~235°C	Min 30s
Peak (D)	235°C~260°C	Min 40s
Peak (E)	260°C	Max 10s

