



## THROUGH HOLE TAB-UP RJ-45 JACK WITH 10/100/1000 MAGNETIC

### FEATURES

- 1X1 Tab-UP, 0.85" & 1" long with internal magnetics for 10/100/1000 Base-TX
- 350  $\mu$  H minimum OCL with 8mA bias current
- Internal magnetics options available
- Minimum 1500Vrms isolation
- Recognized by UL 60950-1



### ELECTRICAL SPECIFICATIONS @25°C-Operating temperature 0°C TO 70°C

Part Number	Turns Ratio		Insertion Loss (dB MAX)	Return Loss (dB MIN @100 $\Omega$ ±15 $\Omega$ )				Differential to Common Mode Rejection (dB MIN)			Cross talk (dB MIN)			Hipot (VRMS)
	TX	RX		0.3-100MHz	1-30 MHz	40 MHz	50 MHz	60-100 MHz	30 MHz	60 MHz	100 MHz	30 MHz	60 MHz	
46F-1301GDD2	1CT:1CT	1CT:1CT	-1.2	-16	-13.5	-11.5	-10	-35	-32	-30	-40	-36	-30	1500
46F-1302GYD2	1CT:1CT	1CT:1CT	-1.2	-16	-13.5	-11.5	-10	-35	-32	-30	-40	-36	-30	1500
46F-1301GYD2	1CT:1CT	1CT:1CT	-1.2	-16	-13.5	-11.5	-10	-35	-32	-30	-40	-36	-30	1500
46F-1303GYD2	1CT:1CT	1CT:1CT	-1.2	-16	-13.5	-11.5	-10	-35	-32	-30	-40	-36	-30	1500
47F-1302GYD2	1CT:1CT	1CT:1CT	-1.1	-15	-15	-15	-12	-35	-32	-30	-35	-26	-24	1500
46F-1201YGD2	1CT:1	1CT:1CT	-1.2	-14	-14	-14	-10	-35	-32	-30	-40	-36	-30	1500
46F-1202YGD2	1CT:1CT	1CT:1CT	-1.2	-14	-14	-14	-10	-35	-32	-30	-40	-36	-30	1500
46F-1203GGD2	1CT:1CT	1CT:1CT	-1.2	-14	-14	-14	-10	-35	-32	-30	-40	-36	-30	1500

### Part Number:

46F - 1301 GDD NW 2 NL  
 A B C D E F

- A: Series
- B: Schematics
- C: Led
- D: Mechanical
- E: Gold Plating: 1=3u", 2=6u", 3=15u", 4=30u", 5=50u"
- F: RoHS Version

### MARKINGS AND DIMENSION

#### 46F-12XX

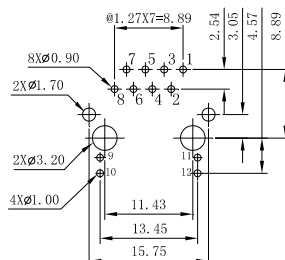
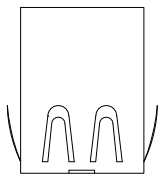

PC Board Layout  
Component Side Shown

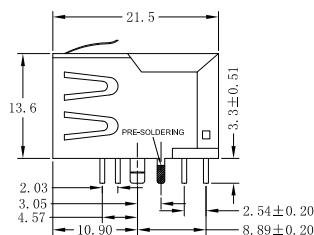
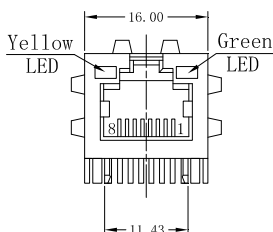

#### LED Configuration:

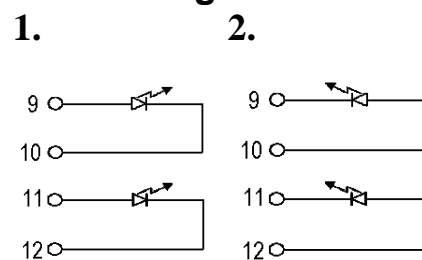

Standard LED	Wavelength	Forward* V(MAX)	(TYP)
Yellow	585 nm	2.5 V	2.1 V
Green	565 nm	2.5 V	2.2 V

\* With a forward current of 20 mA

UNIT:mm Unless otherwise specified, all tolerances are ±0.25



MARKINGS AND DIMENSION

46F-13XX

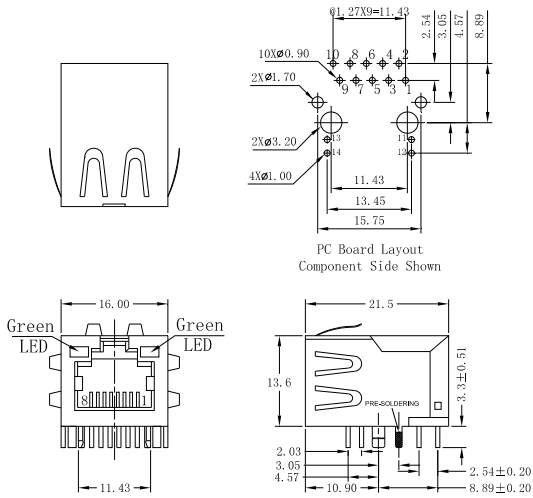

LED Configuration:

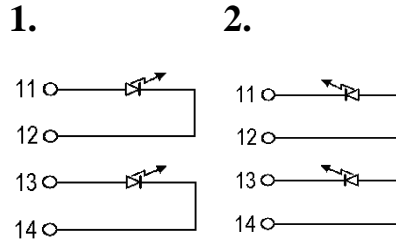

Standard LED	Wavelength	Forward* V(MAX)	(TYP)
Yellow	585 nm	2.5 V	2.1 V
Green	565 nm	2.5 V	2.2 V

\* With a forward current of 20 mA

UNIT:mm Unless otherwise specified, all tolerances are ±0.25

47F-13XX

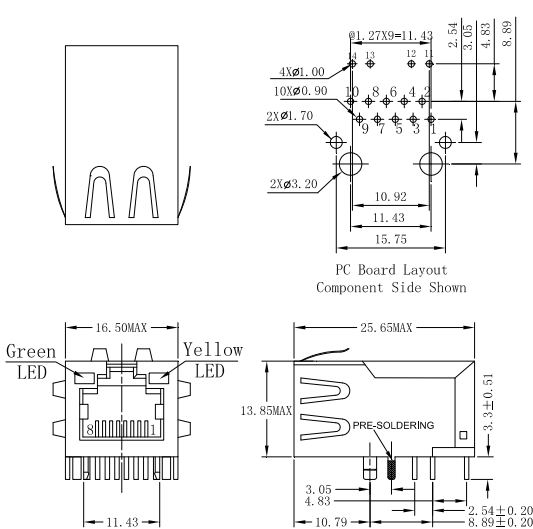

LED Configuration:

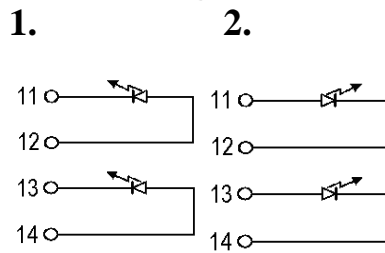

Standard LED	Wavelength	Forward* V(MAX)	(TYP)
Yellow	585 nm	2.5 V	2.1 V
Green	565 nm	2.5 V	2.2 V

\* With a forward current of 20 mA

UNIT:mm Unless otherwise specified, all tolerances are ±0.25

MATERIALS

1.Housing Material:

MATERIAL:NYLON +25% GF (Fr50) UL94V-0  
STANDARD COLOR:BLACK

2.Insert Material:

MATERIAL:Phos-Bronze C5210 EH--0.35mm Thickness  
Insert -PBT+30% GF UL94V-0

- 1.PLATING(1) NICKEL
- 2.PLATING(2) 100%Sn
- 3.PLATING(3) GOLD FLASH (3u " ~ 50u " )

3.Plate Material:PBT-4830 +30% GF UL 94V-0

4.Contact pin Material:

MATERIAL: Phos-Bronze C5210 EH--0.35mm Thickness

- 1.PLATING(1) NICKEL
- 2.PLATING(2) 100%Sn

5.Shielding Material:

BRASS C2680 H.---0.25mm THICKNESS  
PLATING NICKEL

6.Operation Life : 750 Cycles Min.

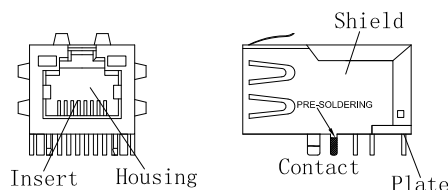



SCHEMATICS

46F-1201

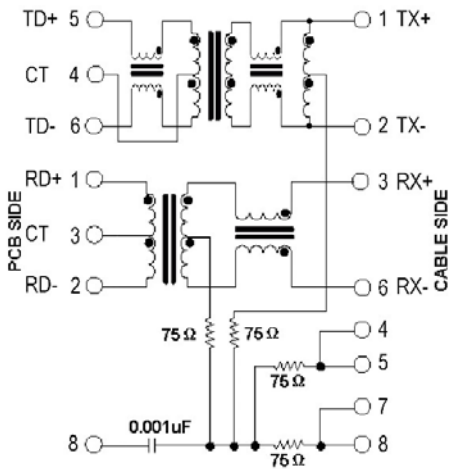

46F-1202

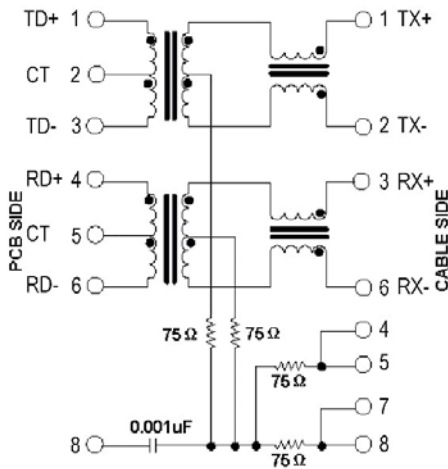

46F-1202A

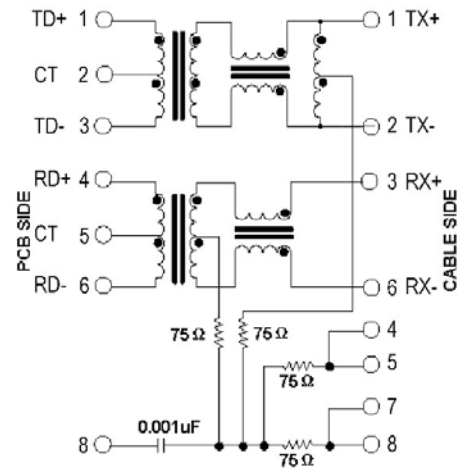

46F-1203

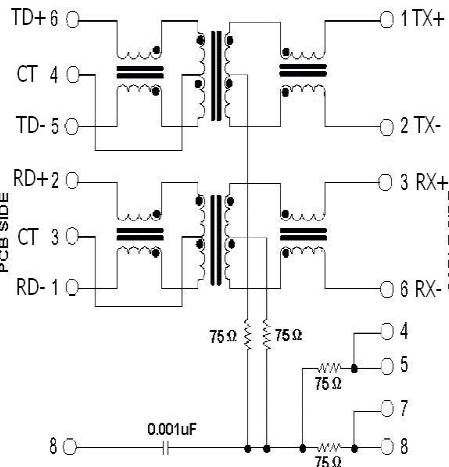

46F-1206

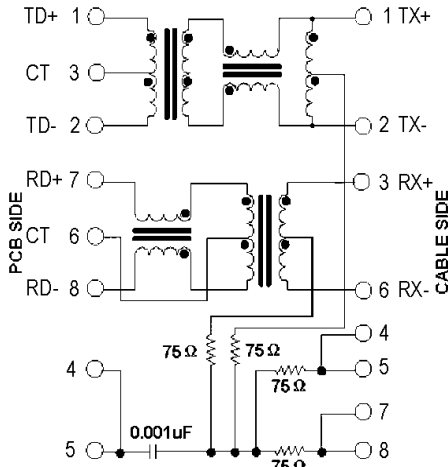

46F-1207

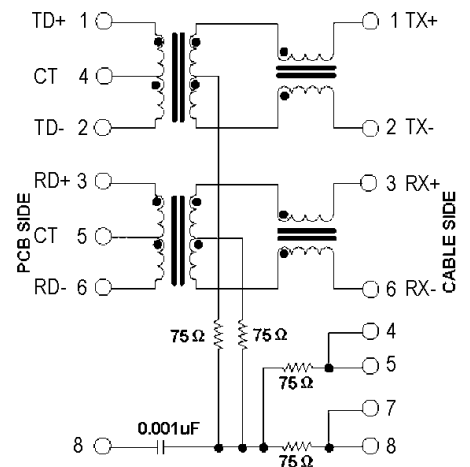

46F-1208

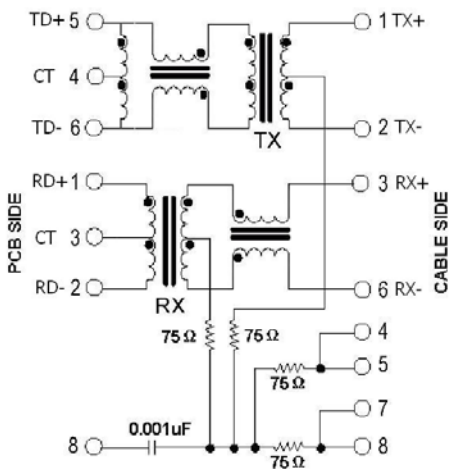

46F-1209

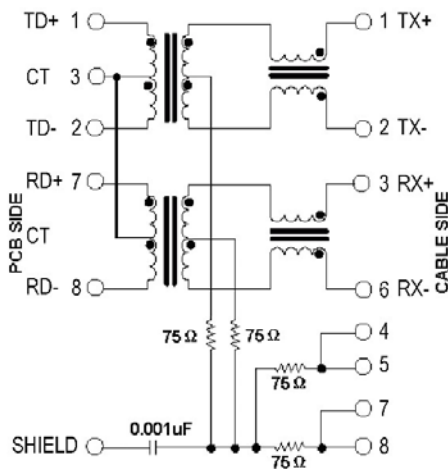

46F-1210

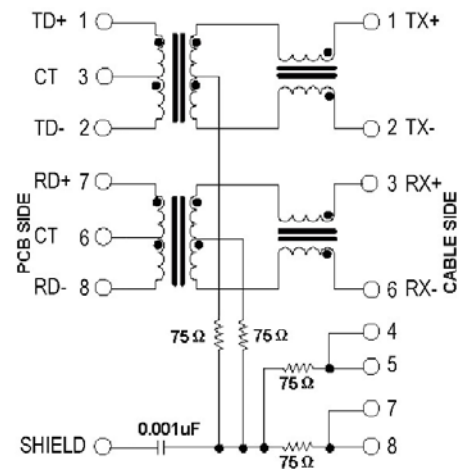

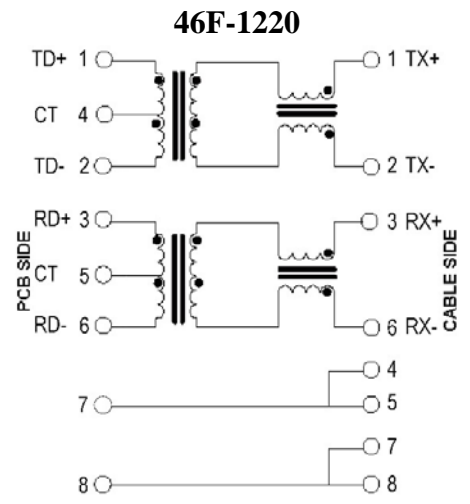
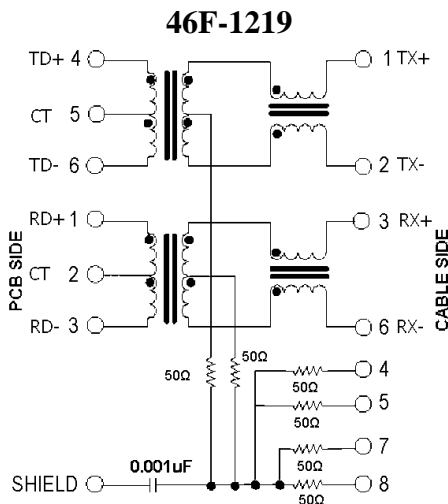
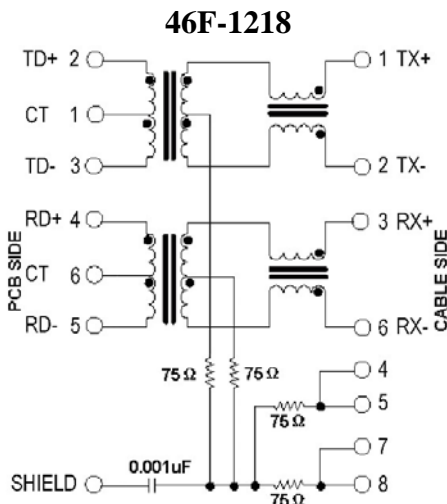
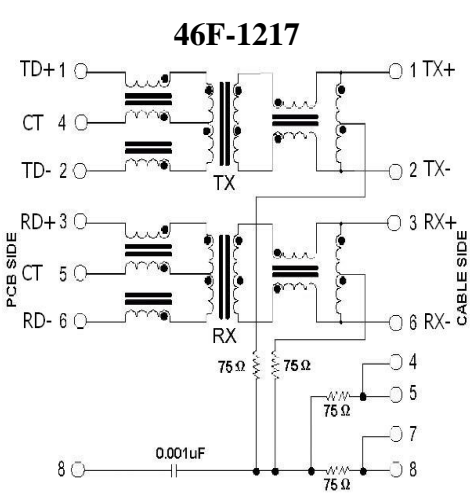
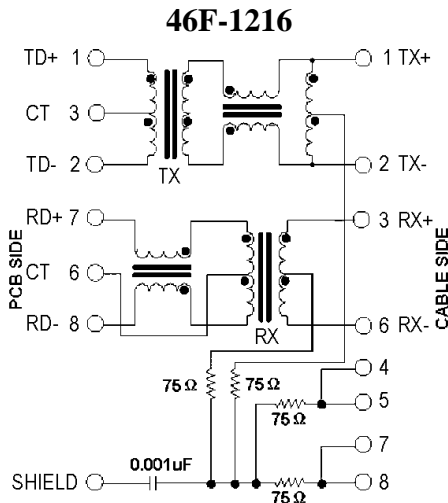
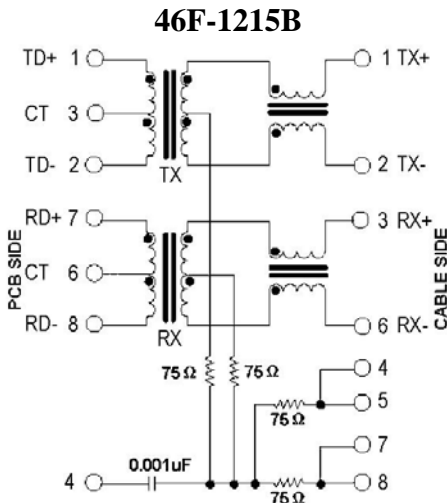
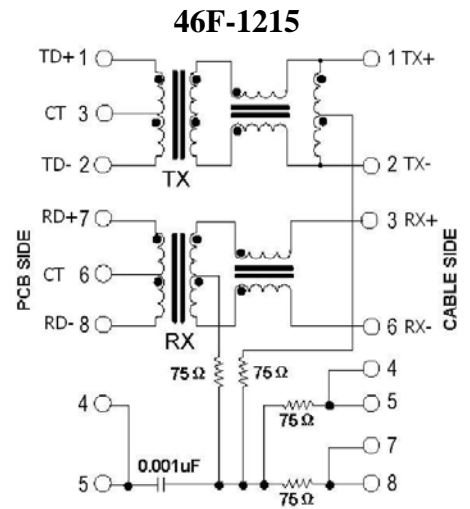
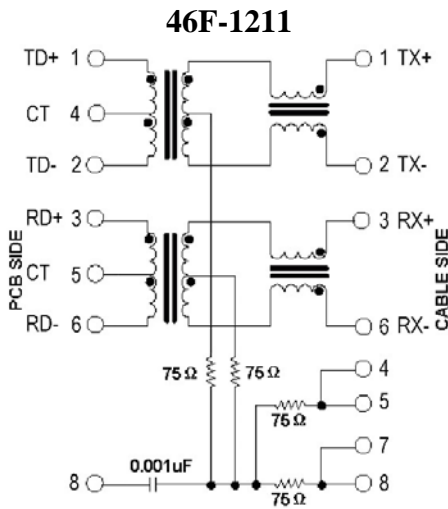
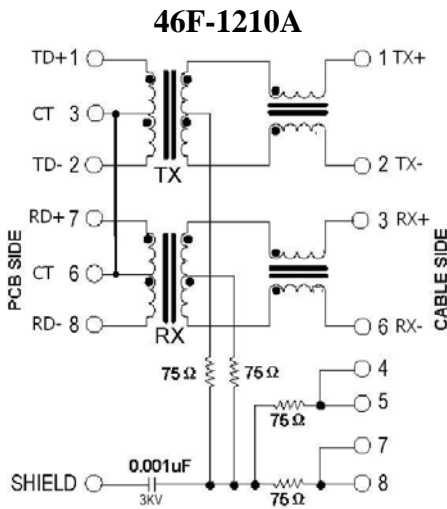



1301

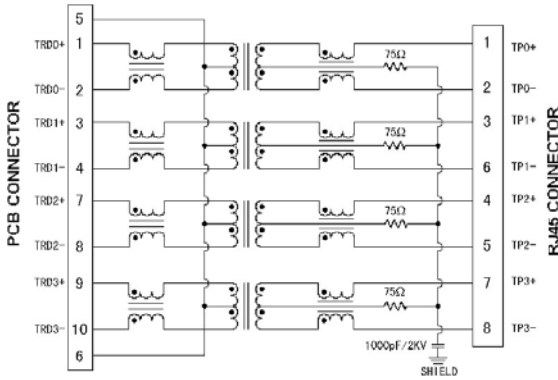

1302

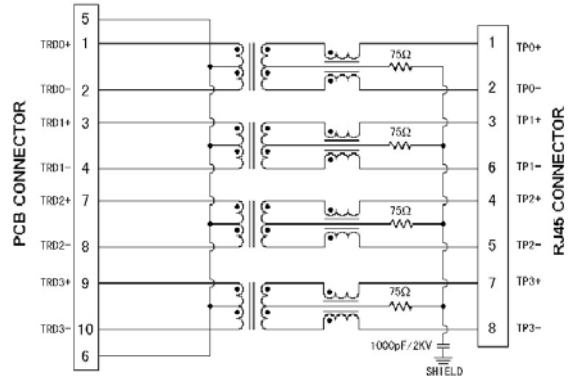

1303

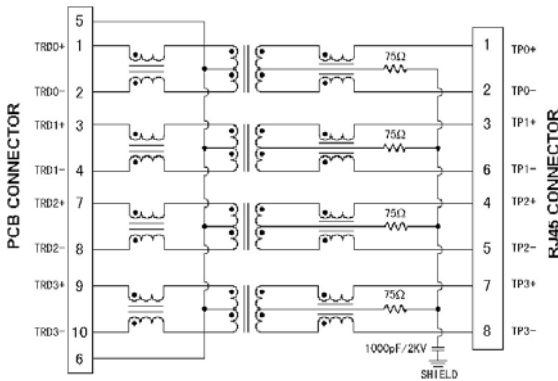

1304

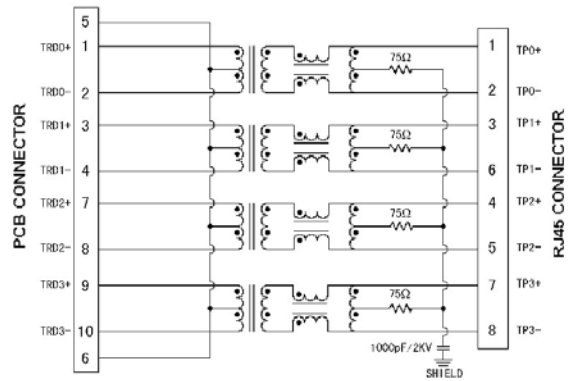

1305

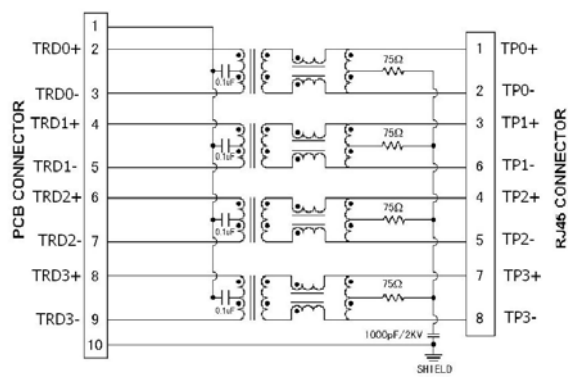

1306

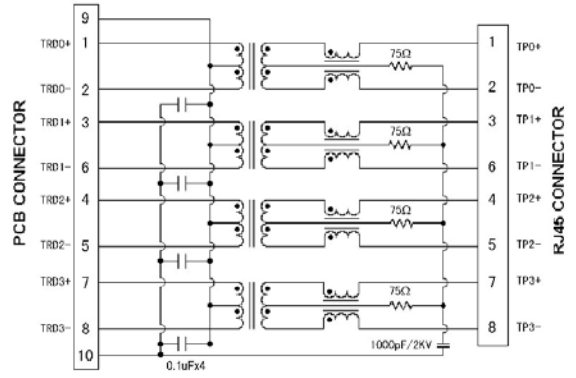

1308

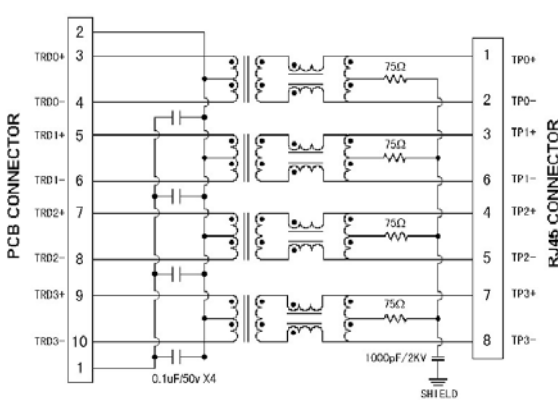

1309

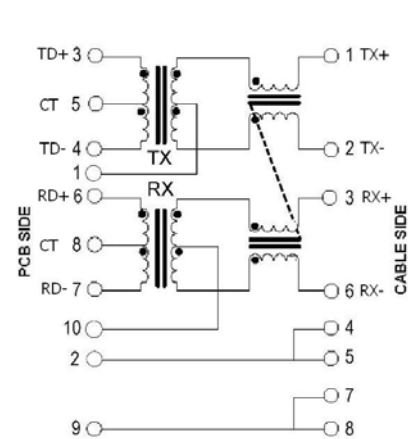



THROUGH HOLE TAB- UP RJ-45 JACK WITH 10/100/1000 MAGNETIC

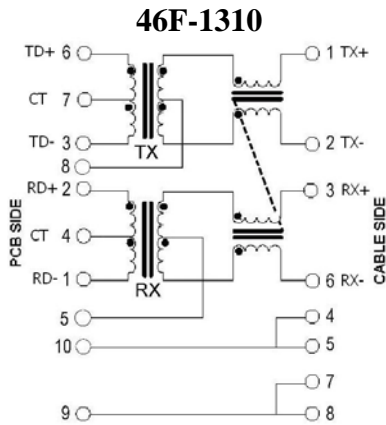

1313

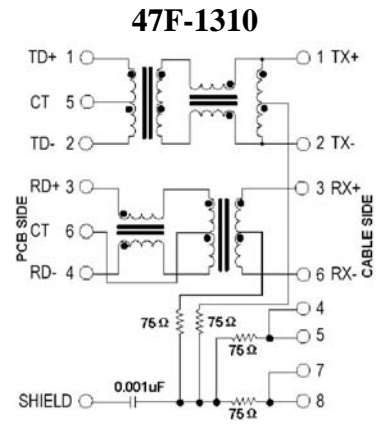

1314

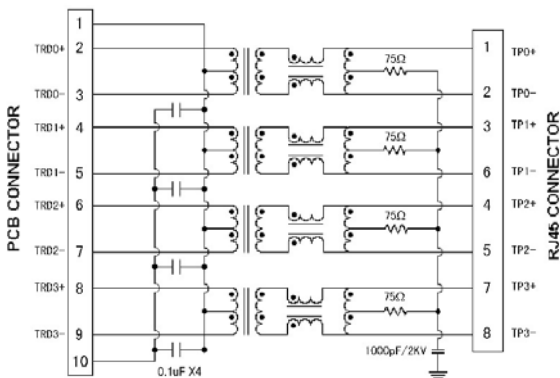

1316

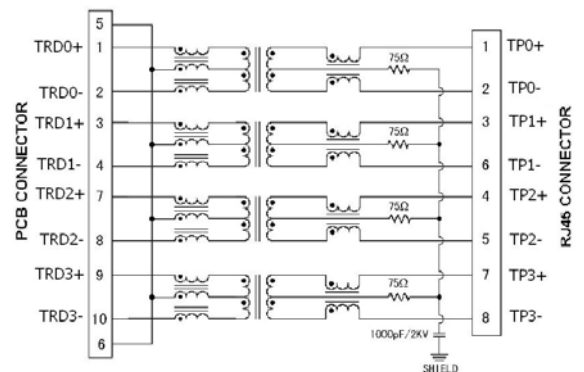

1318

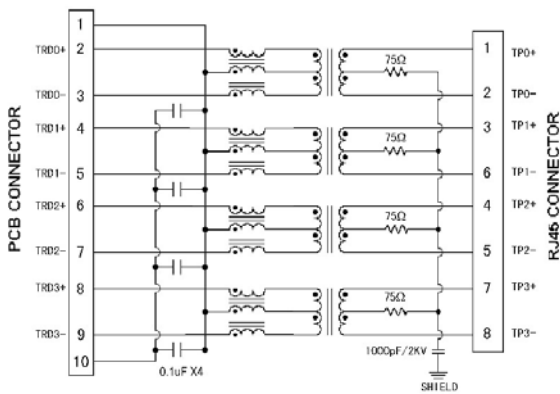

1319

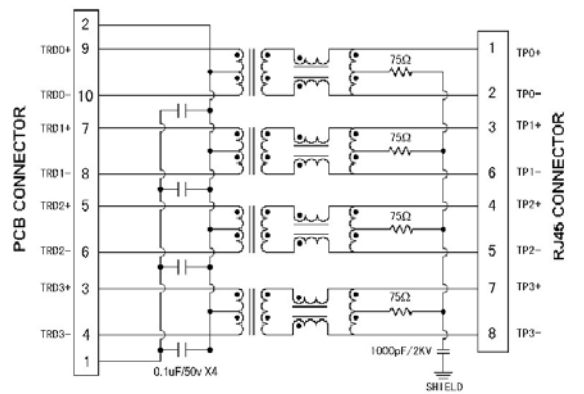

1320

