



SPECIFICATIONS

CONTACT RATING: 0.4 VA max. @20 V AC or DC max.

MECHANICAL LIFE: 50,000 make-and-break cycles.

CONTACT RESISTANCE: Below 100mΩ typ. initial @ 2-4VDC, 100mA.

INSULATION RESISTANCE: DC500V 500MΩ.

DIELECTRIC STRENGTH: 500 V rms min. @sea level.

OPERATING TEMPERATURE: -30°C to 85°C.

MATERIALS

CASE & BUSHING: Glass filled nylon 6/6, flame retardant, heat stabilized (UL 94V-0)

ACTUATOR: Nylon, black std.

SWITCH SUPPORT: Brass or steel, tin plated.

CONTACTS/TERMINALS: Silver or gold plated copper alloy

HOW TO ORDER

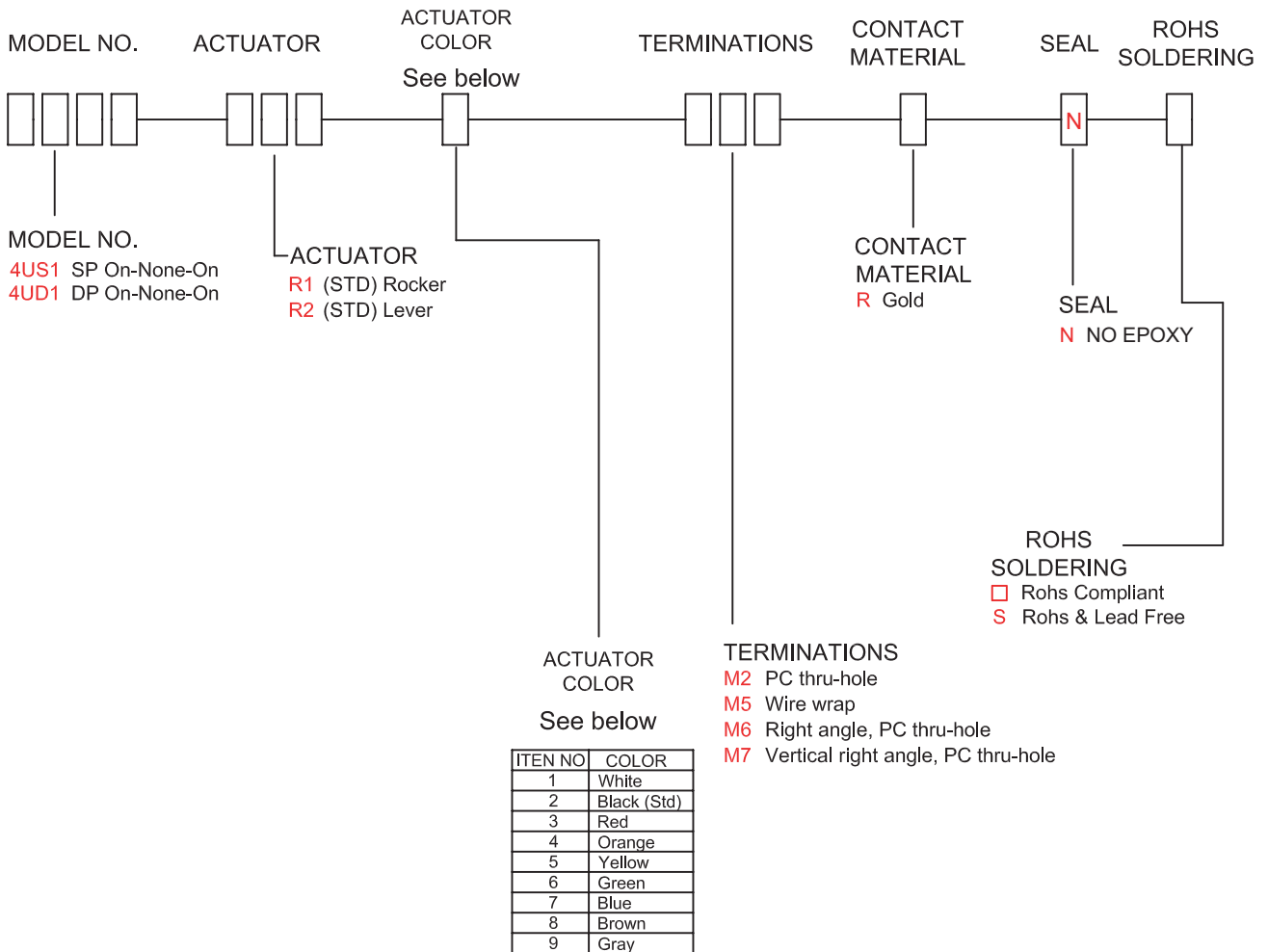

SWITCH FUNCTION

NO. POLES	MODEL NO.	SWITCH FUNCTION			CONNECTED TERMINALS / SCHEMATIC		
		POS.1	POS.2	POS.3	POS.1	POS.2	POS.3
SP	4US1	ON	NONE	ON	5-6	OPEN	5-4
DP	4UD1	ON	NONE	ON	5-6,2-3	OPEN	5-4,2-1

MOM=MOMENTARY

ACTUATOR OPTIONS / PANEL MOUNT

R1

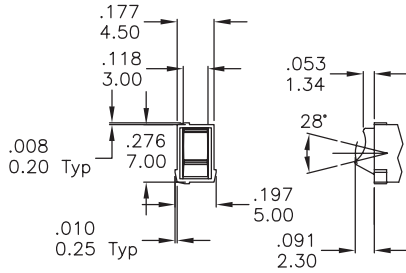

R2

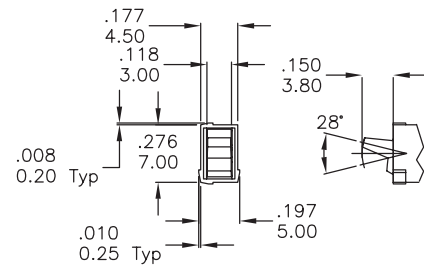

POLE OPTIONS

M2

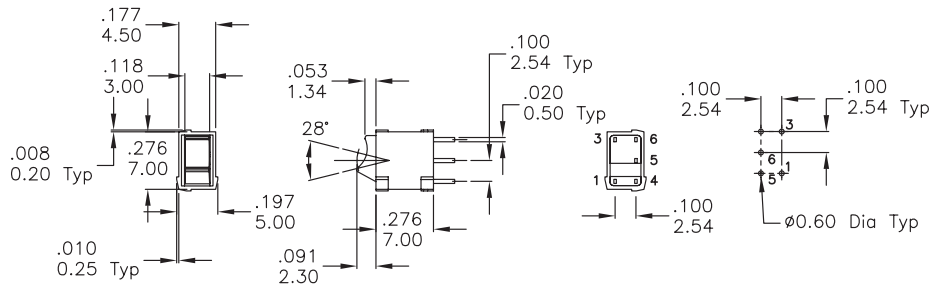

SPDT

Part No. Shown:4US1R102M2RNS

M2

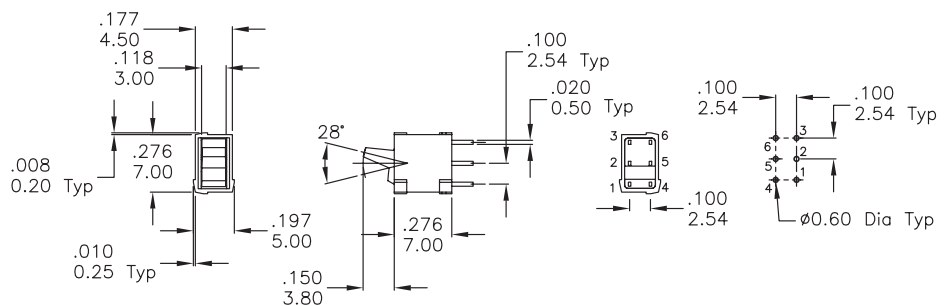

DPDT

Part No. Shown:4UD1R202M2RNS

4U Series

Sub-Miniature Rocker Switches

M6

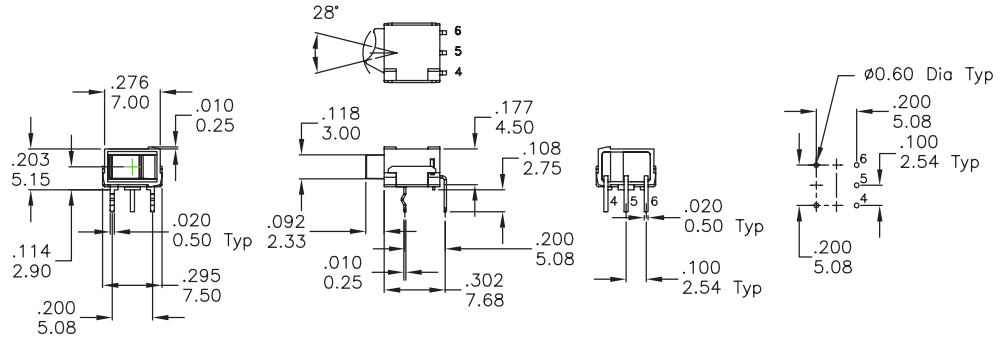

SPDT

Part No. Shown: 4US1R102M6RNS

M6

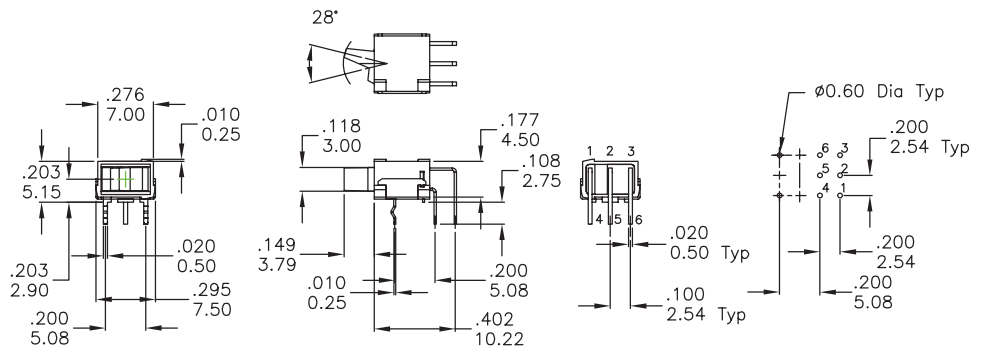

DPDT

Part No. Shown: 4UD1R202M6RNS

M7

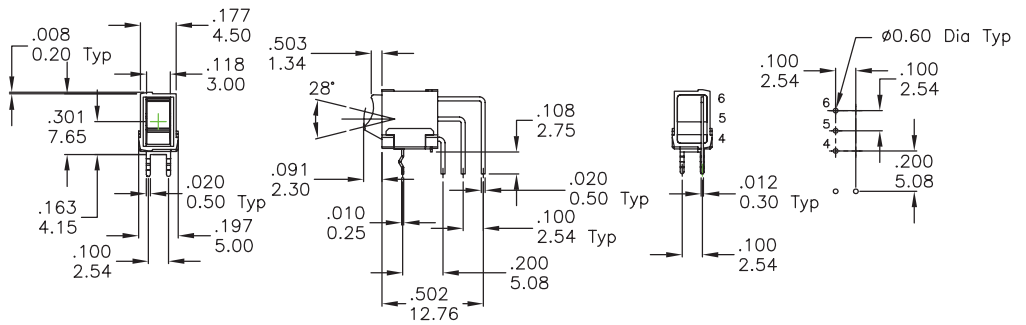

SPDT

Part No. Shown: 4US1R102M7RNS

M7

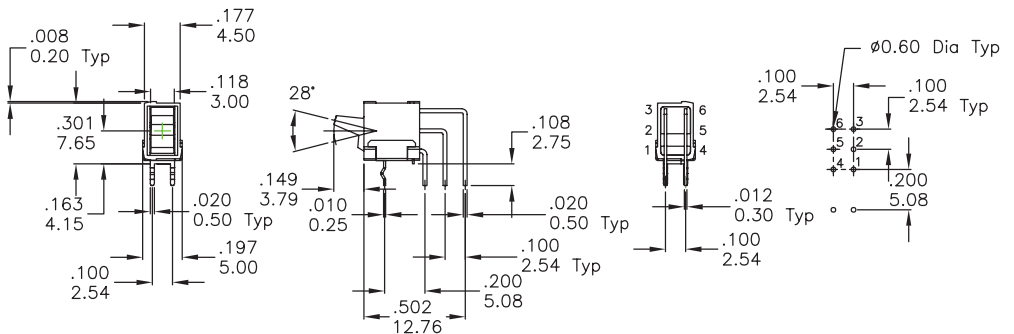

DPDT

Part No. Shown: 4UD1R202M7RNS

Sub-Miniature Rocker Switches

4U



IP 67

ACCORDING TO
EN 60529:1991+A1:2001
IEC 60529:2001

SOLDERING PROCESSES

WAVE SOLDERING : Recommended Soldering Temperature: $260 \pm 5^\circ\text{C}$
Duration of Solder Immersion: 5 ± 1 seconds
(PCB is 1.6mm in thickness)

SOLDERING : Vapor phase

Temperature Profile

Zone	Room temperature	Time (Sec)
Pre-heat (A)	150°C	Min 120s
Soak (B)	$180^\circ\text{C} \sim 200^\circ\text{C}$	Min 150s
Peak (C)	$200^\circ\text{C} \sim 235^\circ\text{C}$	Min 30s
Peak (D)	$235^\circ\text{C} \sim 260^\circ\text{C}$	Min 40s
Peak (E)	260°C	Max 10s

