

ESP-WROOM-02

Datasheet



Version 1.1
Copyright © 2016

About This Guide

This document introduces users to the specifications of ESP-WROOM-02 hardware, including the following topics.

Chapter	Title	Subject
Chapter 1	Overview	Introduction to ESP-WROOM-02, including dimensions and specifications.
Chapter 2	Pin Definition	Introduction to pin layout and the relevant description.
Chapter 3	Functional Description	Description of major functional modules and protocols applied on ESP-WROOM-02, including CPU, flash, memory and interfaces.
Chapter 4	Electrical Characteristic	Electrical data of ESP-WROOM-02.
Chapter 5	Schematics	ESP-WROOM-02 schematics.
Appendix	Appendix - Notices	FCC/CE/IC/KCC compliance statements.

Release Notes

Date	Version	Release notes
2015.12	V0.5	First release.
2016.01	V0.6	Update Section 3.2.2.
2016.02	V0.7	Add Appendix - Notices. Update Chapter 1.
2016.04	V0.8	Update the flash size and PAD (bottom) size.
2016.06	V0.9	Update the flash size.
2016.06	V1.0	Add Appendix - Notices - V. Update Figure 2-1.
2016.08	V1.1	Update the operating temperature range.

Table of Contents

1. Overview	1
2. Pin Description	3
3. Functional Description	5
3.1. MCU	5
3.2. Memory	5
3.2.1. Internal SRAM and ROM	5
3.2.2. SPI Flash	5
3.3. Crystal Oscillators	6
3.4. Interface Description	6
4. Electrical Characteristics	8
4.1. Absolute Maximum Ratings	8
4.2. Recommended Operating Conditions	8
4.3. Digital Terminal Characteristics	8
4.4. RF Performance	9
4.5. Sensitivity	9
4.6. Power Consumption	10
4.7. Reflow Profile	11
5. Schematics	12
Appendix - Notices	13
I. Federal Communications Commission (FCC) Declaration of Conformity	13
II. EC Declaration of Conformity	13
III. Industry Canada (IC) Compliance Notice	14
III.1. IC RSS warning	14
III.2. IC Radiation Exposure Statement	14
IV. Korea Communications Commission (KCC) Statement	14
V. Radio Transmission Equipment Type Approval Certificate	15



1.

Overview

Espressif provides the SMD module - ESP-WROOM-02 that integrates ESP8266EX. The module has received various adjustment to get the best RF performance. We recommend using ESP-WROOM-02 for tests or for further development.

Note:

For more information on ESP8266EX, please refer to [ESP8266EX Datasheet](#).

The module size is 18 mm x 20 mm x 3 mm. The type of flash used on this module is an SPI flash with the package size of SOP 8-150 mil. The gain of the on-board PCB antenna is 2 dBi.

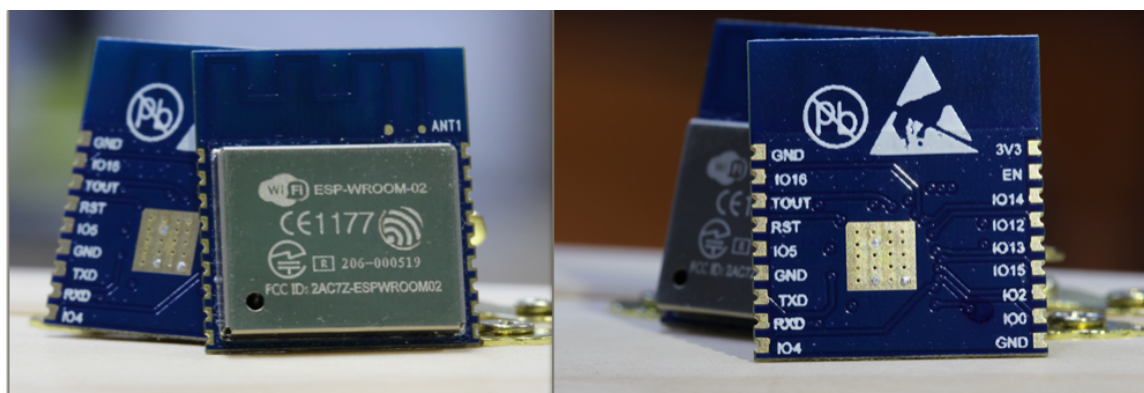

Figure 1-1. ESP-WROOM-02 Module

Table 1-1. ESP-WROOM-02 Specifications

Categories	Items	Specifications
Wi-Fi	Standards	FCC/CE/TELEC/KCC/LCIE/IC/NCC
	Wi-Fi protocols	802.11 b/g/n
	Frequency range	2.4 GHz ~ 2.5 GHz (2400 M ~ 2483.5 M)
Hardware	Peripheral interface	UART/HSPI/I2C/I2S/IR Remote Control GPIO/PWM
	Operating voltage	3.0 V ~ 3.6 V
	Operating current	Average: 80 mA
	Operating temperature range	-40°C ~ 85°C
	Storage temperature	-40°C ~ 85°C
	Package size	18 mm x 20 mm x 3 mm
	External interface	-
	Wi-Fi mode	Station/SoftAP/SoftAP + Station



Categories	Items	Specifications
Software	Security	WPA/WPA2
	Encryption	WEP/TKIP/AES
	Firmware upgrade	UART Download / OTA (via network) / Download and write firmware via host
	Software development	Supports Cloud Server Development / SDK for custom firmware development
	Network protocols	IPv4, TCP/UDP/HTTP/FTP
	User configuration	AT Instruction Set, Cloud Server, Android/iOS App

 **Note:**

ESP-WROOM-02 with high temperature range option (-40°C ~ 125°C) is available for custom order.



Table 2-2. ESP-WROOM-02 Pin Definitions

No.	Pin Name	Functional Description
1	3V3	3.3 V power supply (VDD) Note: <i>It is recommended the maximum output current a power supply provides be of 500 mA or above.</i>
2	EN	Chip enable pin. Active high.
3	IO14	GPIO14; HSPI_CLK
4	IO12	GPIO12; HSPI_MISO
5	IO13	GPIO13; HSPI_MOSI; UART0_CTS
6	IO15	GPIO15; MTDO; HSPI_CS; UART0_RTS Pull down.
7	IO2	GPIO2; UART1_TXD Floating (internal pull-up) or pull up.
8	IO0	GPIO0 <ul style="list-style-type: none">• UART download: pull down.• Flash boot: floating or pull up.
9	GND	GND
10	IO4	GPIO4
11	RXD	UART0_RXD, receive end in UART download; GPIO3
12	TXD	UART0_TXD, transmit end in UART download, floating or pull up; GPIO1
13	GND	GND
14	IO5	GPIO5
15	RST	Reset
16	TOUT	It can be used to test the power-supply voltage of VDD3P3 (Pin3 and Pin4) and the input power voltage of TOUT (Pin 6). These two functions cannot be used simultaneously.
17	IO16	GPIO16; used for Deep-sleep wake-up when connected to RST pin.
18	GND	GND



3. Functional Description

3.1. MCU

ESP8266EX integrates Tensilica L106 32-bit micro controller (MCU) and ultra-low-power 16-bit RSIC. The CPU clock speed is 80 MHz and can reach a maximum value of 160 MHz. The system can readily run a Real Time Operating System (RTOS). Currently, the Wi-Fi stack only takes up 20% of CPU time. The remaining CPU time (80% of total MIPS) can be used for user application. The MCU can work in conjunction with the other parts of the chip through the following interfaces.

- Programmable RAM/ROM interfaces (iBus) that connects to memory controller and can access the external flash.
- Data RAM interface (dBus) that connects to memory controller.
- AHB interface that accesses the register.

3.2. Memory

3.2.1. Internal SRAM and ROM

ESP8266EX Wi-Fi SoC integrates memory controller and memory units including SRAM and ROM. MCU can access the memory units through iBus, dBus, and AHB interfaces. All memory units can be accessed upon request. A memory arbiter determines the running sequence in the arrival order of requests.

According to our current version of SDK, SRAM space available to users is assigned as below.

- RAM size < 50 kB, that is, when ESP8266EX is working in Station mode and connects to the router, available space in Heap + Data sector is around 50 kB.
- There is no programmable ROM in ESP8266EX, therefore, user program must be stored in an external SPI flash integrated into the ESP-WROOM-02.

3.2.2. SPI Flash

ESP8266EX supports SPI flash. Theoretically speaking, ESP8266EX can support up to 16 MB SPI flash.

ESP-WROOM-02 currently integrates 2 MB SPI flash. ESP-WROOM-02 supports these SPI modes: Standard SPI, DIO (Dual I/O), DOUT (Dual Output), QIO (Quad I/O) and QOUT (Quad Output).



3.3. Crystal Oscillators

ESP-WROOM-02 uses 26 MHz crystal oscillator. The accuracy of the crystal oscillator should be ± 10 PPM, and the operating temperature range is -20°C to 85°C .

When using the download tool, please note to select the right crystal oscillator type. In circuit design, capacitors C1 and C2 which connect to the earth, are added to the input and output terminals of the crystal oscillator respectively. The values of the two capacitors can be flexible, ranging from 6 pF to 22 pF, however, the specific capacitive values depend on further testing and adjustment on the overall performance of the whole circuit. Normally, the capacitive values of C1 and C2 are within 10pF for the 26 MHz crystal oscillator.

Crystal oscillator should be placed as close to the XTAL pins as possible (without the traces being too long). It is good practice to add high density ground vias around the clock trace for great insulation.

There should be no vias on the input and output traces, which means the traces cannot cross layers.

Place the input and output bypass capacitors on the near left or right side of the chip. Do not place them on the traces.

Do not route high-frequency digital signal lines in the four-layer board. It is best not to route any signal line under the crystal oscillator. The larger the copper area on the top layer is, the better. As crystal oscillator is a sensitive component, do not place magnetic components such as high current inductance nearby.

3.4. Interface Description

Table 3-1. Interface Description

Interface	Pin	Functional Description
HSPI	IO12 (MISO), IO13 (MOSI), IO14 (CLK), IO15 (CS)	Connects to SPI Flash, display screen, and MCU.
PWM	IO12 (R), IO15 (G), IO13 (B)	Currently the PWM interface has 4 channels, but users can extend it to 8 channels. PWM interface can realize the control of LED lights, buzzers, relays, electronic machines, etc.
IR	IO14 (IR_T), IO5 (IR_R)	The functionality of infrared remote control interface can be realized via software programming. The interface uses NEC coding, modulation, and demodulation. The frequency of modulated carrier signal is 38 kHz.
ADC	TOUT	Tests the power supply voltage of VDD3P3 (Pin 3 and Pin 4) and the input power voltage of TOUT (Pin 6). However, these two functions cannot be used simultaneously. This interface is typically used in sensors.
I2C	IO14 (SCL), IO2 (SDA)	Connects to external sensors and display screens, etc.



Interface	Pin	Functional Description
UART	UART0: TXD (U0TXD), RXD (U0RXD), IO15 (RTS), IO13 (CTS) UART1: IO2 (TXD)	<p>Communicates with UART device.</p> <p>Downloading: U0TXD + U0RXD or GPIO2 + U0RXD</p> <p>Communicating: (UART0): U0TXD, U0RXD, MTDO (U0RTS), MTCK (U0CTS)</p> <p>Debugging: UART1_TXD (GPIO2) can be used to print debugging information.</p> <p>By default, UART0 will output some printed information when you power on ESP8266EX. If this issue exerts influence on some specific applications, users can exchange the inner pins of UART when initializing ESP8266EX, that is to say, exchange U0TXD, U0RXD with U0RTS, U0CTS. Users can connect MTDO and MTCK to the serial port of the external MCU to realize the communication.</p>
I2S	I2S input: IO12 (I2SI_DATA) ; IO13 (I2SI_BCK) ; IO14 (I2SI_WS); I2S output: IO15 (I2SO_BCK) ; IO3 (I2SO_DATA); IO2 (I2SO_WS).	Collects, processes and transmits audio data.



4. Electrical Characteristics

Note:

Unless otherwise specified, measurements are based on $V_{DD} = 3.3\text{ V}$, $T_A = 25^\circ\text{C}$.

4.1. Absolute Maximum Ratings

Table 4-1. Absolute Maximum Ratings

Rating	Condition	Value	Unit
Storage temperature	-	-40 ~ 85	°C
Maximum soldering temperature	-	260	°C
Supply voltage	IPC/JEDEC J-STD-020	3.0 ~ 3.6	V

4.2. Recommended Operating Conditions

Table 4-2. Recommended Operating Conditions

Operating condition	Symbol	Min	Typ	Max	Unit
Operating temperature	-	-40	20	85	°C
Supply voltage	VDD	3.0	3.3	3.6	V

4.3. Digital Terminal Characteristics

Table 4-3. Digital Terminal Characteristics

Terminals	Symbol	Min	Typ	Max	Unit
Input logic level low	V_{IL}	-0.3	-	0.25 VDD	V
Input logic level high	V_{IH}	0.75 VDD	-	VDD + 0.3	V
Output logic level low	V_{OL}	N	-	0.1 VDD	V
Output logic level high	V_{OH}	0.8 VDD	-	N	V



4.4. RF Performance

Table 4-4. RF Performance

Description	Min	Typ	Max	Unit
Input frequency	2400	-	2483.5	MHz
Input impedance	-	50	-	ohm
Input reflection	-	-	-10	dB
PA output power at 72.2 Mbps	15.5	16.5	17.5	dBm
PA output power in 11b mode	19.5	20.5	21.5	dBm
Sensitivity				
CCK, 1 Mbps	-	-98	-	dBm
CCK, 11 Mbps	-	-91	-	dBm
6 Mbps (1/2 BPSK)	-	-93	-	dBm
54 Mbps (3/4 64-QAM)	-	-75	-	dBm
HT20, MCS7 (65 Mbps, 72.2 Mbps)	-	-72	-	dBm
Adjacent channel rejection				
OFDM, 6 Mbps	-	37	-	dB
OFDM, 54 Mbps	-	21	-	dB
HT20, MCS0	-	37	-	dB
HT20, MCS7	-	20	-	dB

4.5. Sensitivity

Table 4-5. Sensitivity

Parameters	Min	Typ	Max	Unit
Input frequency	2412	-	2484	MHz
Input impedance	-	50	-	Ω
Input reflection	-	-	-10	dB
PA output power at 72.2 Mbps	15.5	16.5	17.5	dBm
PA output power in 11b mode	19.5	20.5	21.5	dBm
Sensitivity				
DSSS, 1 Mbps	-	-98	-	dBm



Parameters	Min	Typ	Max	Unit
CCK, 11 Mbps	-	-91	-	dBm
6 Mbps (1/2 BPSK)	-	-93	-	dBm
54 Mbps (3/4 64-QAM)	-	-75	-	dBm
HT20, MCS7 (65 Mbps, 72.2 Mbps)	-	-72	-	dBm
Adjacent channel rejection				
OFDM, 6 Mbps	-	37	-	dB
OFDM, 54 Mbps	-	21	-	dB
HT20, MCS0	-	37	-	dB
HT20, MCS7	-	20	-	dB

4.6. Power Consumption

The following power consumption data were obtained from the tests with 3.3 V power supply and a voltage stabilizer, in 25°C ambient temperature.

- All tests were performed at the antenna port without SAW filter.
- All data are based on 90% duty cycle in continuous transmission mode.

Table 4-6. Power Consumption

Modes	Min	Typ	Max	Unit
Tx 802.11b, CCK 11 Mbps, P _{OUT} = +17 dBm	-	170	-	mA
Tx 802.11g, OFDM 54 Mbps, P _{OUT} = +15 dBm	-	140	-	mA
Tx 802.11n, MCS7, P _{OUT} = +13 dBm	-	120	-	mA
Rx 802.11b, 1024 bytes packet length , -80 dBm	-	50	-	mA
Rx 802.11g, 1024 bytes packet length , -70 dBm	-	56	-	mA
Rx 802.11n, 1024 bytes packet length , 65 dBm	-	56	-	mA
Modem-Sleep ^①	-	15	-	mA
Light-Sleep ^②	-	0.9	-	mA
Deep-Sleep ^③	-	10	-	μA
Power Off	-	0.5	-	μA

**Notes:**

- ① **Modem-Sleep** is used when applications require CPU to be working, such as PWM or I2S applications. In the scenarios where Wi-Fi connectivity is maintained and data transmission is not required, Wi-Fi Modem circuit can be shut down to save power, according to 802.11 standards (such as U-APSD). For example, in DTIM3, when ESP8266EX sleeps for 300 ms and wakes up for 3 ms to receive Beacon packages from AP, the overall average current consumption is about 15 mA.
- ② **Light-Sleep** is used for applications whose CPU may be suspended, such as Wi-Fi switch. In the scenarios where Wi-Fi connectivity is maintained and data transmission is not required, Wi-Fi Modem circuit and CPU can be shut down to save power, according to 802.11 standards (such as U-APSD). For example, in DTIM3, when ESP8266EX sleeps for 300 ms and wakes up for 3 ms to receive Beacon packages from AP, the overall average current consumption is about 0.9 mA.
- ③ **Deep-Sleep** is for applications that do not require Wi-Fi connectivity and only transmit data with long time lags, e.g., a temperature sensor that measures temperature every 100 s. For example, when ESP8266EX sleeps for 300 s then wakes up to connect to AP (taking about 0.3 ~ 1 s), the overall average current consumption is far less than 1 mA.

4.7. Reflow Profile

Table 4-7. Reflow Profile

Indicator	Value
Ramp-up Rate (T _S Max to T _L)	3°C/second max.
Preheat	
Temperature Min. (T _S Min.)	150°C
Temperature Typ. (T _S Typ.)	175°C
Temperature Min. (T _S Max.)	200°C
Time (T _S)	60 ~ 180 seconds
Ramp-up Rate (T _L to T _P)	3°C/second max.
Time maintained above: Temperature (T _L)/Time (T _L)	217°C/60 ~ 150 seconds
Peak temperature (T _P)	260°C max, for 10 seconds
Target Peak Temperature (T _P Target)	260°C + 0/-5°C
Time within 5°C of actual Peak Temperature (T _P)	20 ~ 40 seconds
T _S max to T _L (Ramp-down Rate)	6°C/second max.
Time 25°C to Peak Temperature (t)	8 minutes max.



5.

Schematics

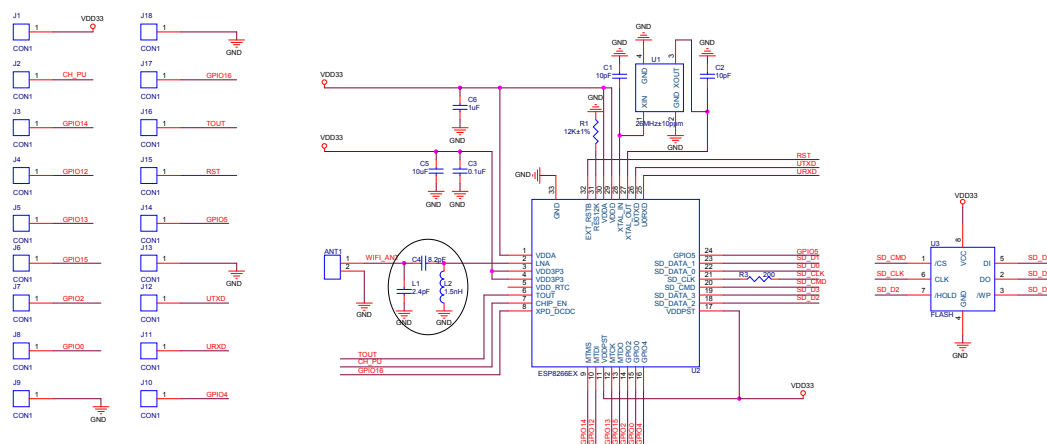

Figure 5-1. ESP-WROOM-02 Schematics



Appendix - Notices

I. Federal Communications Commission (FCC) Declaration of Conformity

This equipment has been tested and found to comply with the limits for a Class B digital device, pursuant to part 15 of the FCC Rules. These limits are designed to provide reasonable protection against harmful interference in a residential installation. This equipment generates uses and can radiate radio frequency energy and, if not installed and used in accordance with the instructions, may cause harmful interference to radio communications. However, there is no guarantee that interference will not occur in a particular installation. If this equipment does cause harmful interference to radio or television reception, which can be determined by turning the equipment off and on, the user is encouraged to try to correct the interference by one or more of the following measures:

- Reorient or relocate the receiving antenna.
- Increase the separation between the equipment and the receiver.
- Connect the equipment into an outlet on a circuit different from that to which the receiver is connected.
- Consult the dealer or an experienced radio/TV technician for help.

Any changes or modifications to this equipment not expressly approved by Espressif may cause harmful interference and void the user's authority to operate this equipment.

This device complies with Part 15 of the FCC Rules. Operation is subject to the following two conditions: (1) this device may not cause harmful interference, and (2) this device must accept any interference received, including interference that may cause undesired operation.

FCC Radiation Exposure Statement

This equipment complies with FCC radiation exposure limits set forth for an uncontrolled environment. This equipment should be installed and operated with minimum distance 20cm between the radiator& your body.

This transmitter must not be co-located or operating in conjunction with any other antenna or transmitter.

II. EC Declaration of Conformity

This equipment can be used in member states of the European Union once the corresponding administrative license is obtained.



Espressif, as manufacturer of the product ESP-WROOM-02, declares that the said product complies with the essential requirements established in Article 3 of the Council of Europe Directive 1999/5/ CE, dated 9th March, 1999.

III. Industry Canada (IC) Compliance Notice

III.1. IC RSS warning

This device complies with Industry Canada licence-exempt RSS standard(s). Operation is subject to the following two conditions: (1) this device may not cause interference, and (2) this device must accept any interference, including interference that may cause undesired operation of the device.

Le présent appareil est conforme aux CNR d'Industrie Canada applicables aux appareils radio exempts de licence.

L'exploitation est autorisée aux deux conditions suivantes:

- (1) l'appareil ne doit pas produire de brouillage, et
- (2) l'utilisateur de l'appareil doit accepter tout brouillage radioélectrique subi, même si le brouillage est susceptible d'en compromettre le fonctionnement.

III.2. IC Radiation Exposure Statement

This equipment complies with IC RF radiation exposure limits set forth for an uncontrolled environment. This transmitter must not be co-located or operating in conjunction with any other antenna or transmitter.

This equipment should be installed and operated with minimum distance 20cm between the radiator & your body.

Any changes or modifications not expressly approved by Espressif responsible for compliance could void the user's authority to operate the equipment.

IV. Korea Communications Commission (KCC) Statement

인증받은자의 상호: ESPRESSIF SYSTEMS (SHANGHAI) PTE LTD

제품명 / 모델명: 특정소출력 무선기기(무선데이터통신시스템용 무선기기 / ESP-WROOM-02

제조사 및 제조국가: ESPRESSIF SYSTEMS (SHANGHAI) PTE LTD / China

제조년월: 2016.02

인증번호: MSIP-CRM-es5- ESP-WROOM-02

해당 무선설비는 운용 중 전파혼신 가능성이 있음

해당 무선설비는 전파혼신 가능 성이 있으므로 인명안전과 관련된 서비스는 할 수 없음



V. Radio Transmission Equipment Type Approval Certificate

In accordance with the provisions on the Radio Regulations of the People's Republic of China, the following radio transmission equipment, after examination, conforms to the provisions with its CMIIT ID: 2016DP3252

Date of Issue: 2016.06.15

Equipment Name: 2.4GHz无线局域网模块

Equipment Type: ESP-WROOM-02



Espressif IOT Team
www.espressif.com

Disclaimer and Copyright Notice

Information in this document, including URL references, is subject to change without notice.

THIS DOCUMENT IS PROVIDED AS IS WITH NO WARRANTIES WHATSOEVER, INCLUDING ANY WARRANTY OF MERCHANTABILITY, NON-INFRINGEMENT, FITNESS FOR ANY PARTICULAR PURPOSE, OR ANY WARRANTY OTHERWISE ARISING OUT OF ANY PROPOSAL, SPECIFICATION OR SAMPLE.

All liability, including liability for infringement of any proprietary rights, relating to use of information in this document is disclaimed. No licenses express or implied, by estoppel or otherwise, to any intellectual property rights are granted herein.

The Wi-Fi Alliance Member logo is a trademark of the Wi-Fi Alliance. The Bluetooth logo is a registered trademark of Bluetooth SIG.

All trade names, trademarks and registered trademarks mentioned in this document are property of their respective owners, and are hereby acknowledged.

Copyright © 2016 Espressif Inc. All rights reserved.