

SN75ALS161

OCTAL GENERAL-PURPOSE INTERFACE BUS TRANSCEIVERS

SLLS019F – JUNE 1986 – REVISED JULY 2004

- Suitable for IEEE Standard 488-1978 (GPIB)
- 8-Channel Bidirectional Transceivers
- Designed to Implement Control Bus Interface
- Designed for Single Controller
- High-Speed Advanced Low-Power Schottky Circuitry
- Low Power Dissipation . . . 46 mW Max Per Channel
- Fast Propagation Times . . . 20 ns Max
- High-Impedance pnp Inputs
- Receiver Hysteresis . . . 650 mV Typ
- Bus-Terminating Resistors Provided on Driver Outputs
- No Loading of Bus When Device Is Powered Down ($V_{CC} = 0$)
- Power-Up/Power-Down Protection (Glitch Free)

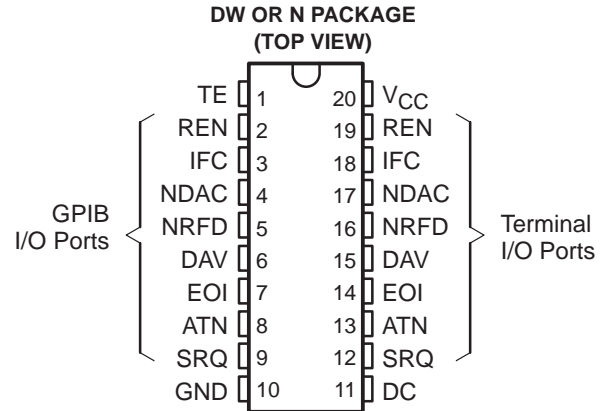

CHANNEL-IDENTIFICATION TABLE

NAME	IDENTITY	CLASS
DC	Direction Control	Control
TE	Talk Enable	
ATN	Attention	Bus Management
SRQ	Service Request	
REN	Remote Enable	
IFC	Interface Clear	
EOI	End or Identify	Data Transfer
DAV	Data Valid	
NDAC	Not Data Accepted	
NRFD	Not Ready for Data	

description/ordering information

The SN75ALS161 eight-channel general-purpose interface bus transceivers are high-speed, advanced low-power Schottky-process devices designed to provide the bus-management and data-transfer signals between operating units of a single-controller instrumentation system. When combined with the SN75ALS160 octal bus transceivers, this device provides a complete 16-wire interface for the IEEE 488 bus.

The SN75ALS161 device features eight driver-receiver pairs connected in a front-to-back configuration to form input/output (I/O) ports at both the bus and terminal sides. The direction of data through these driver-receiver pairs is determined by the direction-control (DC) and talk-enable (TE) signals.

The driver outputs general-purpose interface bus (GPIB I/O ports) feature active bus-terminating resistor circuits designed to provide a high impedance to the bus when $V_{CC} = 0$. The drivers are designed to handle sink-current loads up to 48 mA. Each receiver features pnp transistor inputs for high input impedance and hysteresis of 400 mV on the commercial part, and 250 mV on the military part, minimum, for increased noise immunity. All receivers have 3-state outputs, to present a high impedance to the terminal when disabled.

The SN75ALS161 is characterized for operation from 0°C to 70°C.

ORDERING INFORMATION

TA	PACKAGE†		ORDERABLE PART NUMBER	TOP-SIDE MARKING
0°C to 70°C	PDIP (N)	Tube of 20	SN75ALS161N	SN75ALS161N
	SOIC (DW)	Tube of 25	SN75ALS161DW	75ALS161
		Reel of 2000	SN75ALS161DWR	

† Package drawings, standard packing quantities, thermal data, symbolization, and PCB design guidelines are available at www.ti.com/sc/package.



Please be aware that an important notice concerning availability, standard warranty, and use in critical applications of Texas Instruments semiconductor products and disclaimers thereto appears at the end of this data sheet.

PRODUCTION DATA information is current as of publication date. Products conform to specifications per the terms of Texas Instruments standard warranty. Production processing does not necessarily include testing of all parameters.



POST OFFICE BOX 655303 • DALLAS, TEXAS 75265

Copyright © 2004, Texas Instruments Incorporated

SN75ALS161

OCTAL GENERAL-PURPOSE INTERFACE BUS TRANSCEIVERS

SLLS019F – JUNE 1986 – REVISED JULY 2004

FUNCTION TABLE
RECEIVE/TRANSMIT

CONTROLS			BUS-MANAGEMENT CHANNELS				DATA-TRANSFER CHANNELS			
DC	TE	ATN [†]	ATN [†]	SRQ	REN	IFC	EOI	DAV	NDAC	NRFD
			(CONTROLLED BY DC)					(CONTROLLED BY TE)		
H	H	H	R	T	R	R	T	T	R	R
H	H	L					R			
L	L	H	T	R	T	T	R	R	T	T
L	L	L					T			
H	L	X	R	T	R	R	R	R	T	T
L	H	X	T	R	T	T	T	T	R	R

H = high level, L = low level, R = receive, T = transmit, X = irrelevant

Direction of data transmission is from the terminal side to the bus side, and the direction of data receiving is from the bus side to the terminal side.

Data transfer is noninverting in both directions.

[†] ATN is a normal transceiver channel that functions additionally as an internal direction control or talk enable for EOI whenever the DC and TE inputs are in the same state. When DC and TE are in opposite states, the ATN channel functions as an independent transceiver only.

SN75ALS161 OCTAL GENERAL-PURPOSE INTERFACE BUS TRANSCEIVERS

SLLS019F – JUNE 1986 – REVISED JULY 2004

logic diagram (positive logic)

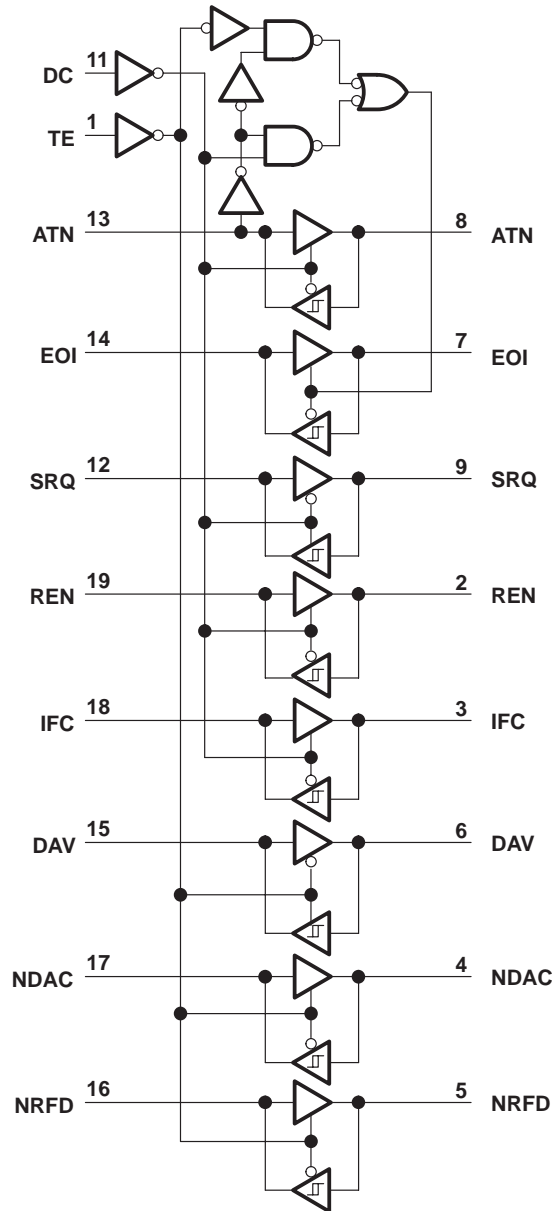

SN75ALS161 OCTAL GENERAL-PURPOSE INTERFACE BUS TRANSCEIVERS

SLLS019F – JUNE 1986 – REVISED JULY 2004

schematics of inputs and outputs

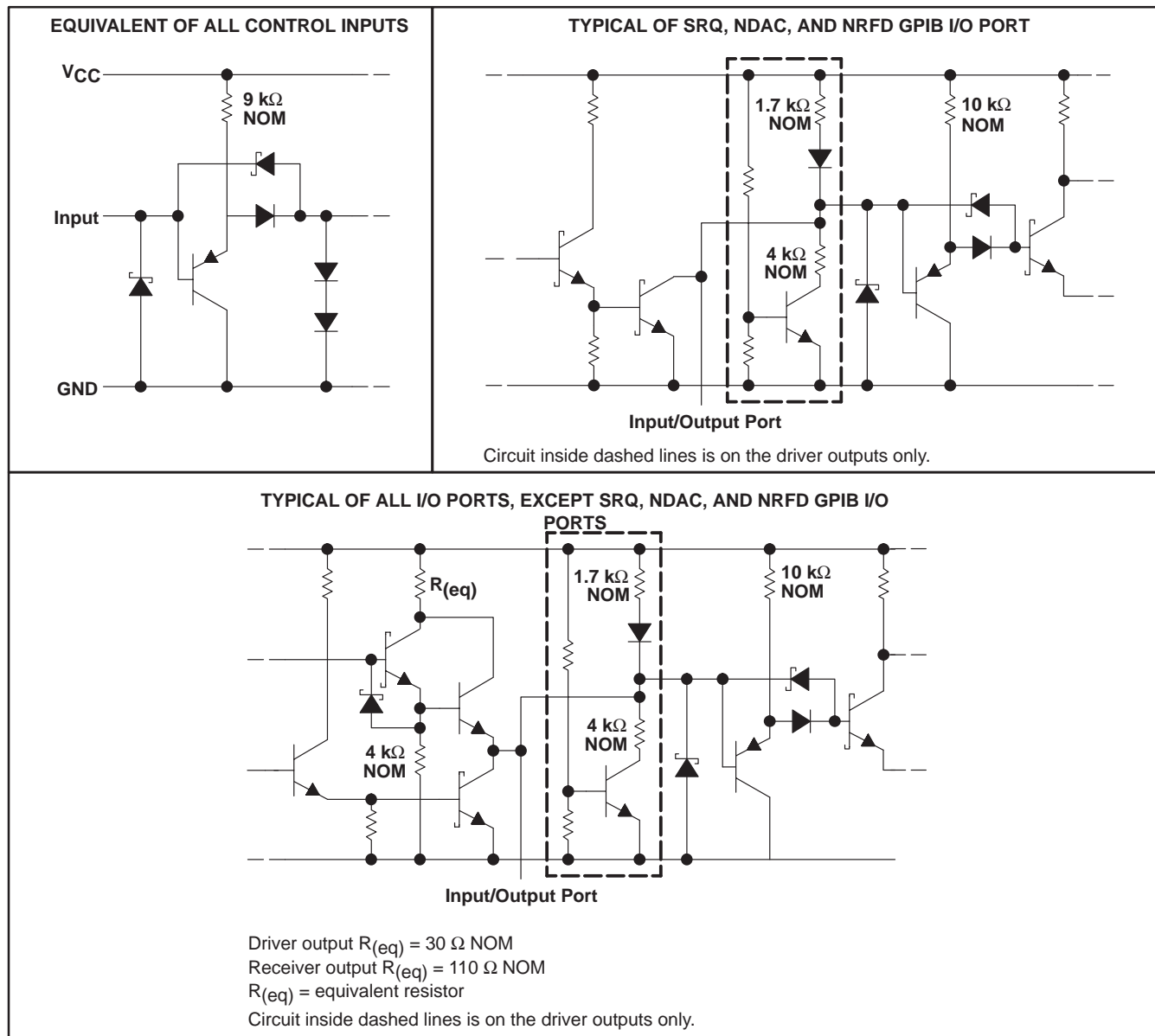

SN75ALS161

OCTAL GENERAL-PURPOSE INTERFACE BUS TRANSCEIVERS

SLLS019F – JUNE 1986 – REVISED JULY 2004

absolute maximum ratings over operating free-air temperature range (unless otherwise noted)†

Supply voltage, V_{CC} (see Note 1)	7 V
Input voltage, V_I	5.5 V
Low-level driver output current, I_{OL}	100 mA
Package thermal impedance, θ_{JA} (see Notes 2 and 3): DW package	58°C/W
N package	69°C/W
Operating virtual junction temperature, T_J	150°C
Storage temperature range, T_{Stg}	–65°C to 150°C

† Stresses beyond those listed under “absolute maximum ratings” may cause permanent damage to the device. These are stress ratings only, and functional operation of the device at these or any other conditions beyond those indicated under “recommended operating conditions” is not implied. Exposure to absolute-maximum-rated conditions for extended periods may affect device reliability.

- NOTES: 1. All voltage values are with respect to network ground terminal.
 2. Maximum power dissipation is a function of $T_{J(max)}$, θ_{JA} , and T_A . The maximum allowable power dissipation at any allowable ambient temperature is $P_D = (T_{J(max)} - T_A)/\theta_{JA}$. Operating at the absolute maximum T_J of 150°C can affect reliability.
 3. The package thermal impedance is calculated in accordance with JESD 51-7.

recommended operating conditions

		MIN	NOM	MAX	UNIT
V_{CC}	Supply voltage	4.75	5	5.25	V
V_{IH}	High-level input voltage	2			V
V_{IL}	Low-level input voltage			0.8	V
I_{OH}	High-level output current	Bus ports with pullups active		– 5.2	mA
		Terminal ports		– 800	μA
I_{OL}	Low-level output current	Bus ports		48	mA
		Terminal ports		16	
T_A	Operating free-air temperature	0		70	°C



SN75ALS161

OCTAL GENERAL-PURPOSE INTERFACE BUS TRANSCEIVERS

SLLS019F – JUNE 1986 – REVISED JULY 2004

electrical characteristics over recommended ranges of supply voltage and operating free-air temperature (unless otherwise noted)

PARAMETER		TEST CONDITIONS†		MIN	TYP‡	MAX	UNIT		
V_{IK}	Input clamp voltage	$I_I = -18 \text{ mA}$		-0.8	-1.5		V		
V_{hys}	Hysteresis voltage ($V_{IT+} - V_{IT-}$)	Bus		0.4	0.65		V		
$V_{OH}§$	High-level output voltage	Terminal	$I_{OH} = -800 \mu\text{A}$, $V_{CC} = \text{MIN}$	$T_A = 25^\circ\text{C}$ and MAX		2.7	3.5	V	
				$T_A = \text{MIN}$		2.7	3.5		
		Bus	$I_{OH} = -5.2 \text{ mA}$, $V_{CC} = \text{MIN}$	$T_A = 25^\circ\text{C}$ and MAX		2.2			
				$T_A = \text{MIN}$		2.2			
V_{OL}	Low-level output voltage	Terminal	$I_{OL} = 16 \text{ mA}$, $V_{CC} = \text{MIN}$		0.3	0.5	V		
		Bus	$I_{OL} = 48 \text{ mA}$, $V_{CC} = \text{MIN}$		0.35	0.5			
I_I	Input current at maximum input voltage	Terminal	$V_I = 5.5 \text{ V}$, $V_{CC} = \text{MAX}$		0.2	100	μA		
I_{IH}	High-level input current	Terminal and control inputs	$V_I = 2.7 \text{ V}$, $V_{CC} = \text{MAX}$		0.1	20	μA		
$V_{I/O}$	Voltage at GPIB I/O port	$I_I(\text{bus}) = 0$		2.5	3	3.7	V		
		$I_I(\text{bus}) = 0$		2.5	3	3.7			
		$I_I(\text{bus}) = -12 \text{ mA}$				-1.5			
I_{IL}	Low-level input current	Terminal and control inputs	$V_I = 0.5 \text{ V}$, $V_{CC} = \text{MAX}$		-10	-100	μA		
$I_{I/O}$	Current into GPIB I/O port	Power on	$V_I(\text{bus}) = -1.5 \text{ V to } 0.4 \text{ V}$		-1.3		mA		
			$V_I(\text{bus}) = 0.4 \text{ V to } 2.5 \text{ V}$		0			-3.2	
			$V_I(\text{bus}) = 2.5 \text{ V to } 3.7 \text{ V}$					2.5	-3.2
			$V_I(\text{bus}) = 3.7 \text{ V to } 5 \text{ V}$		0			2.5	
			$V_I(\text{bus}) = 5 \text{ V to } 5.5 \text{ V}$		0.7			2.5	
		Power off	$V_{CC} = 0$	$V_I(\text{bus}) = 0 \text{ to } 2.5 \text{ V}$				40	μA
$I_{OS}§$	Short-circuit output current	Terminal	$V_{CC} = \text{MAX}$		-15	-35	-75	mA	
		Bus	$V_{CC} = \text{MAX}$		-25	-50	-125		
I_{CC}	Supply current	No load, TE and DC low, $V_{CC} = \text{MAX}$			55	75	mA		
$C_{I/O}$	GPIB I/O port capacitance	$V_{CC} = 0 \text{ to } 5 \text{ V}$, $V_{I/O} = 0 \text{ to } 2 \text{ V}$, $f = 1 \text{ MHz}$			30		pF		

† For conditions shown as MIN or MAX, use the appropriate value specified under recommended operating conditions.

‡ All typical values are at $V_{CC} = 5 \text{ V}$, $T_A = 25^\circ\text{C}$.

§ V_{OH} and I_{OS} apply to 3-state outputs only.



SN75ALS161

OCTAL GENERAL-PURPOSE INTERFACE BUS TRANSCEIVERS

SLLS019F – JUNE 1986 – REVISED JULY 2004

switching characteristics over recommended operating free-air temperature range, $V_{CC} = 5\text{ V}$

PARAMETER		FROM (INPUT)	TO (OUTPUT)	TEST CONDITIONS	MIN	TYP†	MAX	UNIT
t_{PLH}	Propagation delay time, low- to high-level output	Terminal	Bus	$C_L = 30\text{ pF}$, See Figure 1		10	20	ns
t_{PHL}	Propagation delay time, high- to low-level output					12	20	
t_{PLH}	Propagation delay time, low- to high-level output	Bus	Terminal	$C_L = 30\text{ pF}$, See Figure 2		5	10	ns
t_{PHL}	Propagation delay time, high- to low-level output					7	14	
t_{PZH}	Output enable time to high level	TE or DC	Bus (ATN, EOI, REN, IFC, and DAV)	$C_L = 15\text{ pF}$, See Figure 3			30	ns
t_{PHZ}	Output disable time from high level						20	
t_{PZL}	Output enable time to low level						45	
t_{PLZ}	Output disable time from low level						20	
t_{PZH}	Output enable time to high level	TE or DC	Terminal	$C_L = 15\text{ pF}$, See Figure 4			30	ns
t_{PHZ}	Output disable time from high level						25	
t_{PZL}	Output enable time to low level						30	
t_{PLZ}	Output disable time from low level						25	

† All typical values are at $T_A = 25^\circ\text{C}$.

SN75ALS161 OCTAL GENERAL-PURPOSE INTERFACE BUS TRANSCEIVERS

SLLS019F – JUNE 1986 – REVISED JULY 2004

PARAMETER MEASUREMENT INFORMATION

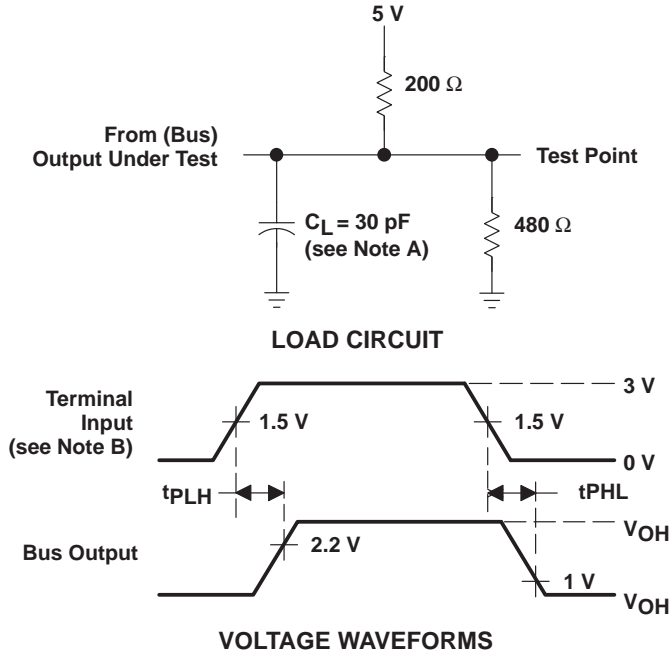

- NOTES: A. C_L includes probe and jig capacitance.
 B. The input pulse is supplied by a generator having the following characteristics: $PRR \leq 1 \text{ MHz}$, 50% duty cycle, $t_r \leq 6 \text{ ns}$, $t_f \leq 6 \text{ ns}$, $Z_O = 50 \Omega$.

Figure 1. Terminal-to-Bus Load Circuit and Voltage Waveforms

PARAMETER MEASUREMENT INFORMATION

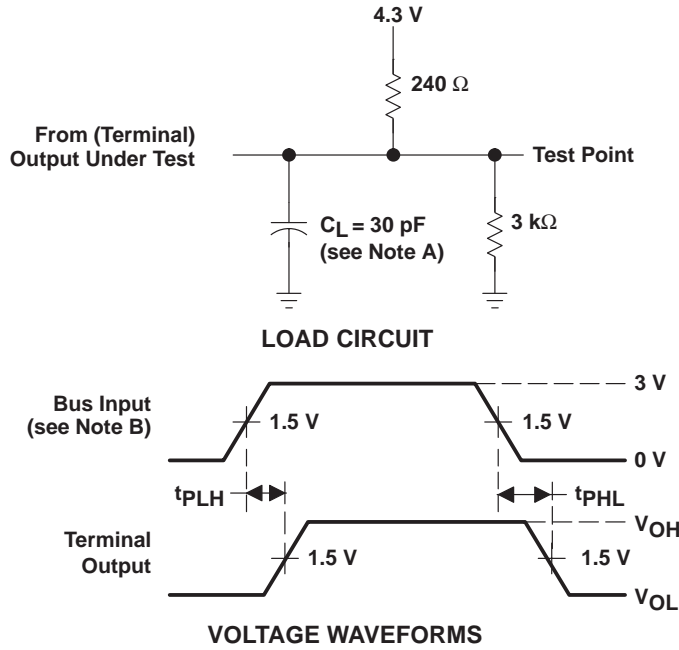

- NOTES: A. C_L includes probe and jig capacitance.
 B. The input pulse is supplied by a generator having the following characteristics: $PRR \leq 1 \text{ MHz}$, 50% duty cycle, $t_r \leq 6 \text{ ns}$, $t_f \leq 6 \text{ ns}$, $Z_O = 50 \Omega$.

Figure 2. Bus-to-Terminal Load Circuit and Voltage Waveforms

SN75ALS161 OCTAL GENERAL-PURPOSE INTERFACE BUS TRANSCEIVERS

SLLS019F – JUNE 1986 – REVISED JULY 2004

PARAMETER MEASUREMENT INFORMATION

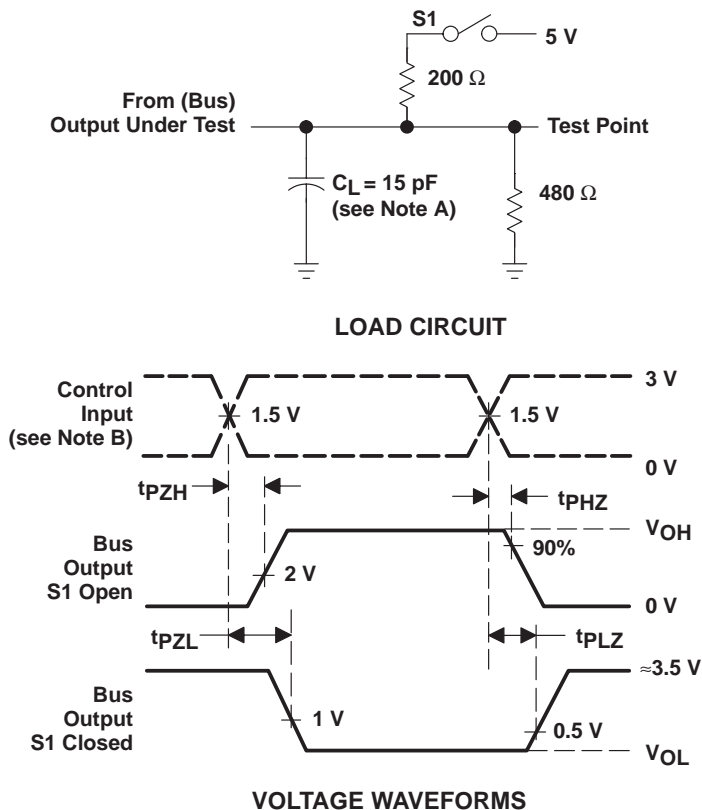

- NOTES: A. C_L includes probe and jig capacitance.
 B. The input pulse is supplied by a generator having the following characteristics: $PRR \leq 1\text{ MHz}$, 50% duty cycle, $t_r \leq 6\text{ ns}$, $t_f \leq 6\text{ ns}$, $Z_O = 50\ \Omega$.

Figure 3. Bus Load Circuit and Voltage Waveforms

PARAMETER MEASUREMENT INFORMATION

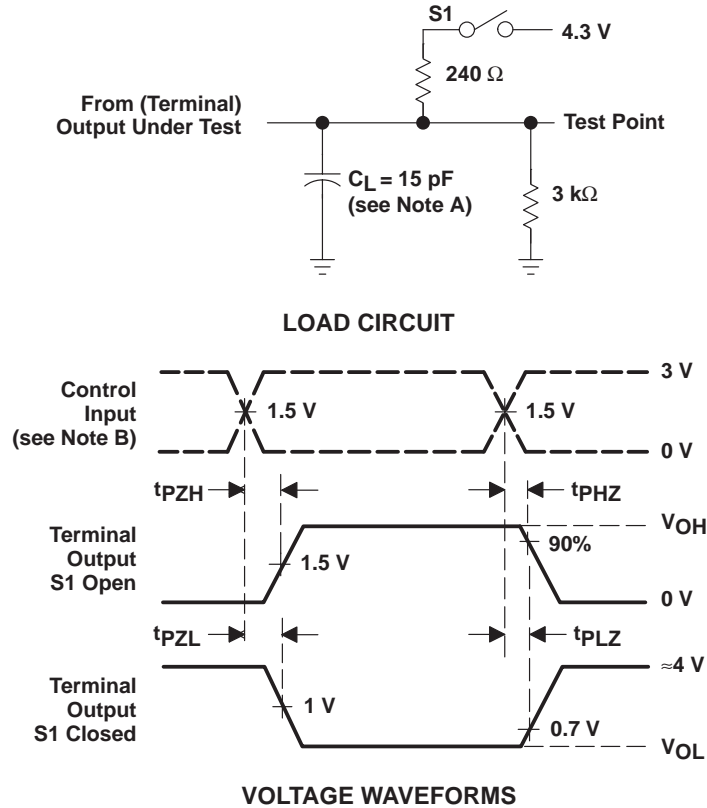

- NOTES: A. C_L includes probe and jig capacitance.
 B. The input pulse is supplied by a generator having the following characteristics: PRR ≤ 1 MHz, 50% duty cycle, t_r ≤ 6 ns, t_f ≤ 6 ns, Z_O = 50 Ω.

Figure 4. Terminal Load Circuit and Voltage Waveforms

SN75ALS161

OCTAL GENERAL-PURPOSE INTERFACE BUS TRANSCEIVERS

SLLS019F – JUNE 1986 – REVISED JULY 2004

TYPICAL CHARACTERISTICS†

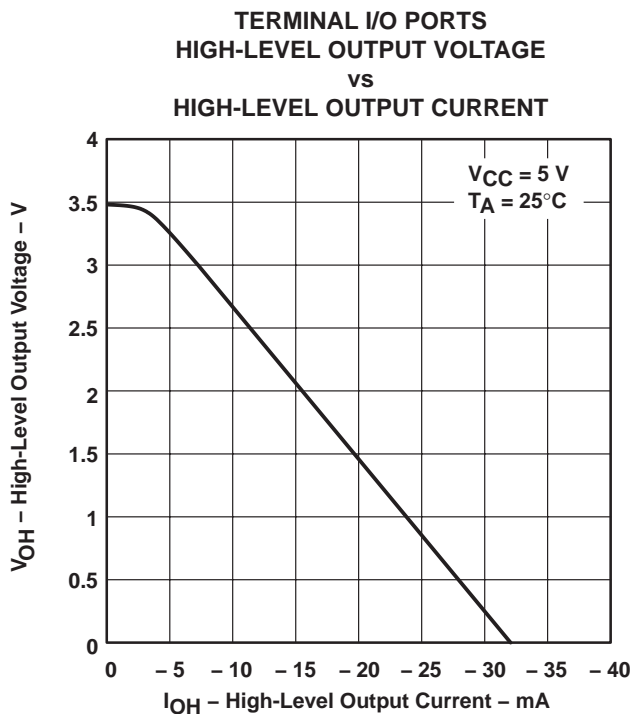

Figure 5

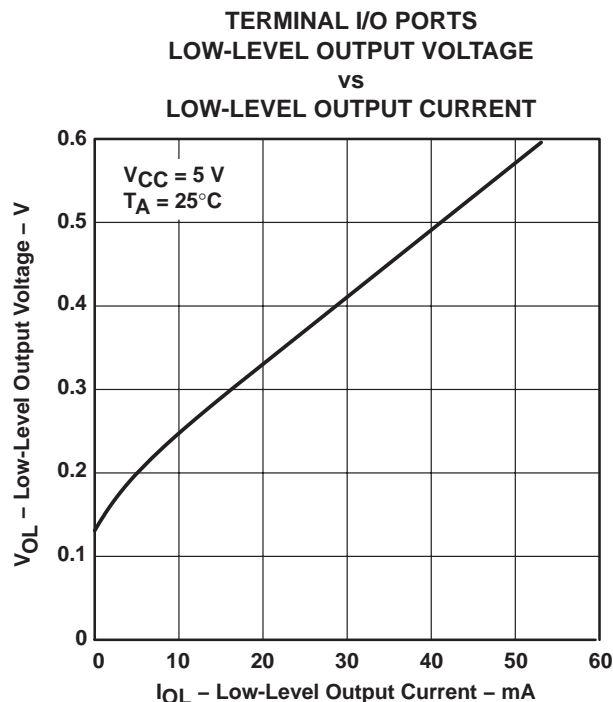

Figure 6

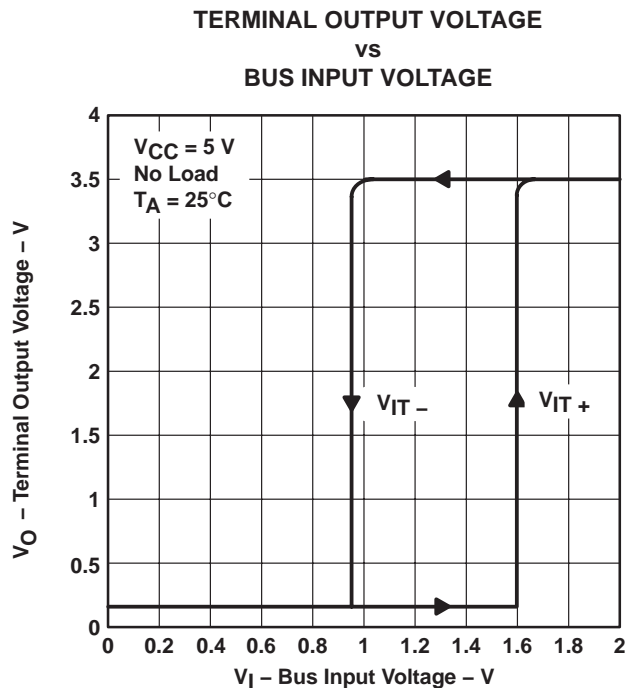

Figure 7

† Operation of the device at these or any other conditions beyond those indicated under "recommended operating conditions" is not implied.

TYPICAL CHARACTERISTICS†

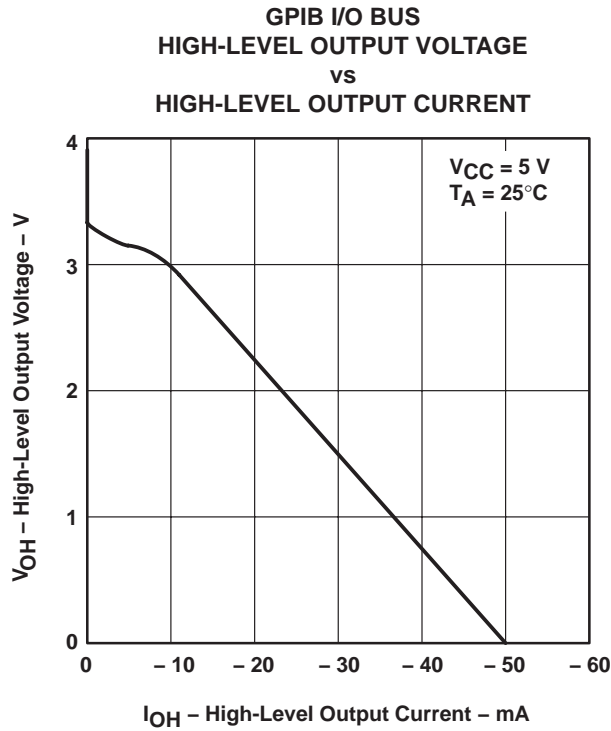

Figure 8

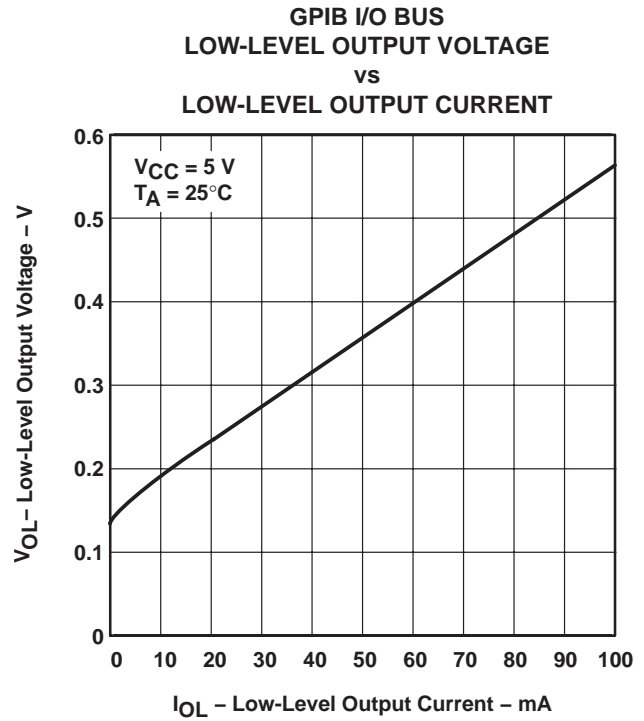

Figure 9

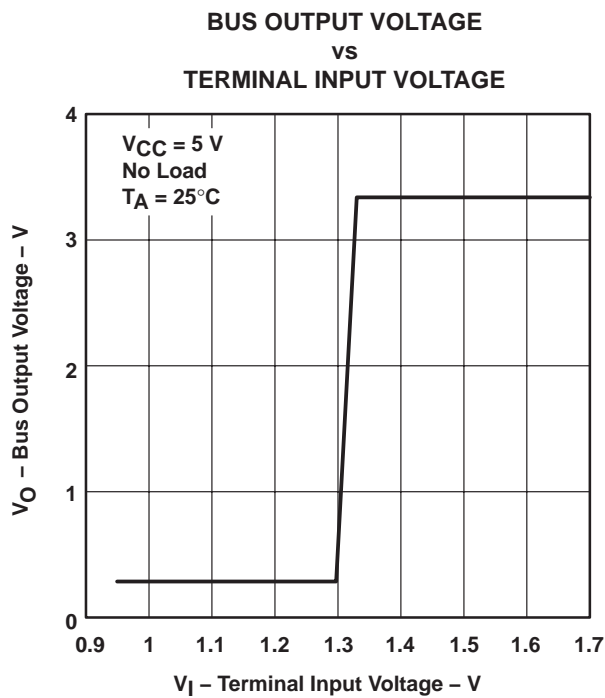

Figure 10

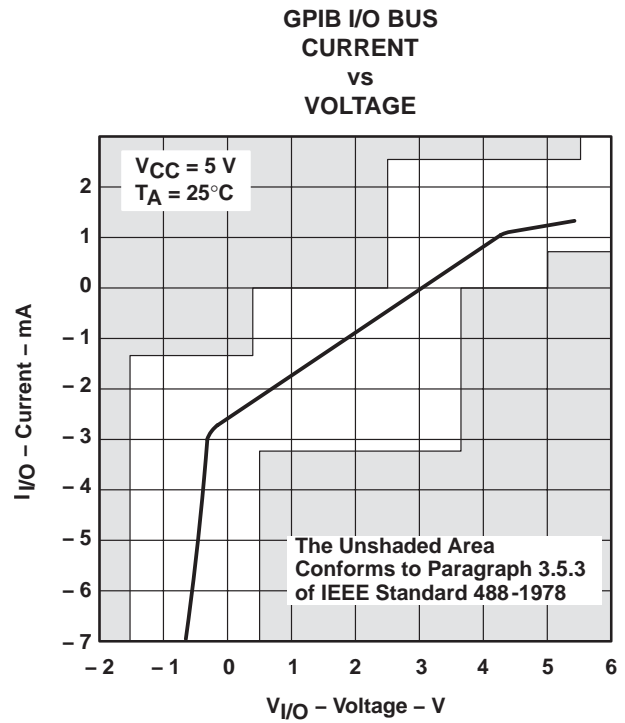

Figure 11

† Operation of the device at these or any other conditions beyond those indicated under "recommended operating conditions" is not implied.

PACKAGING INFORMATION

Orderable Device	Status (1)	Package Type	Package Drawing	Pins	Package Qty	Eco Plan (2)	Lead/Ball Finish (6)	MSL Peak Temp (3)	Op Temp (°C)	Device Marking (4/5)	Samples
SN75ALS161DW	ACTIVE	SOIC	DW	20	25	Green (RoHS & no Sb/Br)	CU NIPDAU	Level-1-260C-UNLIM	0 to 70	75ALS161	Samples
SN75ALS161DWE4	ACTIVE	SOIC	DW	20	25	Green (RoHS & no Sb/Br)	CU NIPDAU	Level-1-260C-UNLIM	0 to 70	75ALS161	Samples
SN75ALS161DWG4	ACTIVE	SOIC	DW	20	25	Green (RoHS & no Sb/Br)	CU NIPDAU	Level-1-260C-UNLIM	0 to 70	75ALS161	Samples
SN75ALS161DWR	ACTIVE	SOIC	DW	20	2000	Green (RoHS & no Sb/Br)	CU NIPDAU	Level-1-260C-UNLIM	0 to 70	75ALS161	Samples
SN75ALS161DWRG4	ACTIVE	SOIC	DW	20	2000	Green (RoHS & no Sb/Br)	CU NIPDAU	Level-1-260C-UNLIM	0 to 70	75ALS161	Samples
SN75ALS161N	ACTIVE	PDIP	N	20	20	Pb-Free (RoHS)	CU NIPDAU	N / A for Pkg Type	0 to 70	SN75ALS161N	Samples

(1) The marketing status values are defined as follows:

ACTIVE: Product device recommended for new designs.

LIFEBUY: TI has announced that the device will be discontinued, and a lifetime-buy period is in effect.

NRND: Not recommended for new designs. Device is in production to support existing customers, but TI does not recommend using this part in a new design.

PREVIEW: Device has been announced but is not in production. Samples may or may not be available.

OBSELETE: TI has discontinued the production of the device.

(2) Eco Plan - The planned eco-friendly classification: Pb-Free (RoHS), Pb-Free (RoHS Exempt), or Green (RoHS & no Sb/Br) - please check <http://www.ti.com/productcontent> for the latest availability information and additional product content details.

TBD: The Pb-Free/Green conversion plan has not been defined.

Pb-Free (RoHS): TI's terms "Lead-Free" or "Pb-Free" mean semiconductor products that are compatible with the current RoHS requirements for all 6 substances, including the requirement that lead not exceed 0.1% by weight in homogeneous materials. Where designed to be soldered at high temperatures, TI Pb-Free products are suitable for use in specified lead-free processes.

Pb-Free (RoHS Exempt): This component has a RoHS exemption for either 1) lead-based flip-chip solder bumps used between the die and package, or 2) lead-based die adhesive used between the die and leadframe. The component is otherwise considered Pb-Free (RoHS compatible) as defined above.

Green (RoHS & no Sb/Br): TI defines "Green" to mean Pb-Free (RoHS compatible), and free of Bromine (Br) and Antimony (Sb) based flame retardants (Br or Sb do not exceed 0.1% by weight in homogeneous material)

(3) MSL, Peak Temp. - The Moisture Sensitivity Level rating according to the JEDEC industry standard classifications, and peak solder temperature.

(4) There may be additional marking, which relates to the logo, the lot trace code information, or the environmental category on the device.

(5) Multiple Device Markings will be inside parentheses. Only one Device Marking contained in parentheses and separated by a "~" will appear on a device. If a line is indented then it is a continuation of the previous line and the two combined represent the entire Device Marking for that device.

⁽⁶⁾ Lead/Ball Finish - Orderable Devices may have multiple material finish options. Finish options are separated by a vertical ruled line. Lead/Ball Finish values may wrap to two lines if the finish value exceeds the maximum column width.

Important Information and Disclaimer:The information provided on this page represents TI's knowledge and belief as of the date that it is provided. TI bases its knowledge and belief on information provided by third parties, and makes no representation or warranty as to the accuracy of such information. Efforts are underway to better integrate information from third parties. TI has taken and continues to take reasonable steps to provide representative and accurate information but may not have conducted destructive testing or chemical analysis on incoming materials and chemicals. TI and TI suppliers consider certain information to be proprietary, and thus CAS numbers and other limited information may not be available for release.

In no event shall TI's liability arising out of such information exceed the total purchase price of the TI part(s) at issue in this document sold by TI to Customer on an annual basis.

OTHER QUALIFIED VERSIONS OF SN75ALS161 :

- Military: [SN55ALS161](#)

NOTE: Qualified Version Definitions:

- Military - QML certified for Military and Defense Applications

TAPE AND REEL INFORMATION



QUADRANT ASSIGNMENTS FOR PIN 1 ORIENTATION IN TAPE



*All dimensions are nominal

Device	Package Type	Package Drawing	Pins	SPQ	Reel Diameter (mm)	Reel Width W1 (mm)	A0 (mm)	B0 (mm)	K0 (mm)	P1 (mm)	W (mm)	Pin1 Quadrant
SN75ALS161DWR	SOIC	DW	20	2000	330.0	24.4	10.8	13.3	2.7	12.0	24.0	Q1

TAPE AND REEL BOX DIMENSIONS



*All dimensions are nominal

Device	Package Type	Package Drawing	Pins	SPQ	Length (mm)	Width (mm)	Height (mm)
SN75ALS161DWR	SOIC	DW	20	2000	367.0	367.0	45.0

N (R-PDIP-T**)

PLASTIC DUAL-IN-LINE PACKAGE

16 PINS SHOWN



4040049/E 12/2002

- NOTES:
- A. All linear dimensions are in inches (millimeters).
 - B. This drawing is subject to change without notice.
 - $\triangle C$ Falls within JEDEC MS-001, except 18 and 20 pin minimum body length (Dim A).
 - $\triangle D$ The 20 pin end lead shoulder width is a vendor option, either half or full width.

DW (R-PDSO-G20)

PLASTIC SMALL OUTLINE



- NOTES:
- All linear dimensions are in inches (millimeters). Dimensioning and tolerancing per ASME Y14.5M-1994.
 - This drawing is subject to change without notice.
 - Body dimensions do not include mold flash or protrusion not to exceed 0.006 (0,15).
 - Falls within JEDEC MS-013 variation AC.

DW (R-PDSO-G20)

PLASTIC SMALL OUTLINE

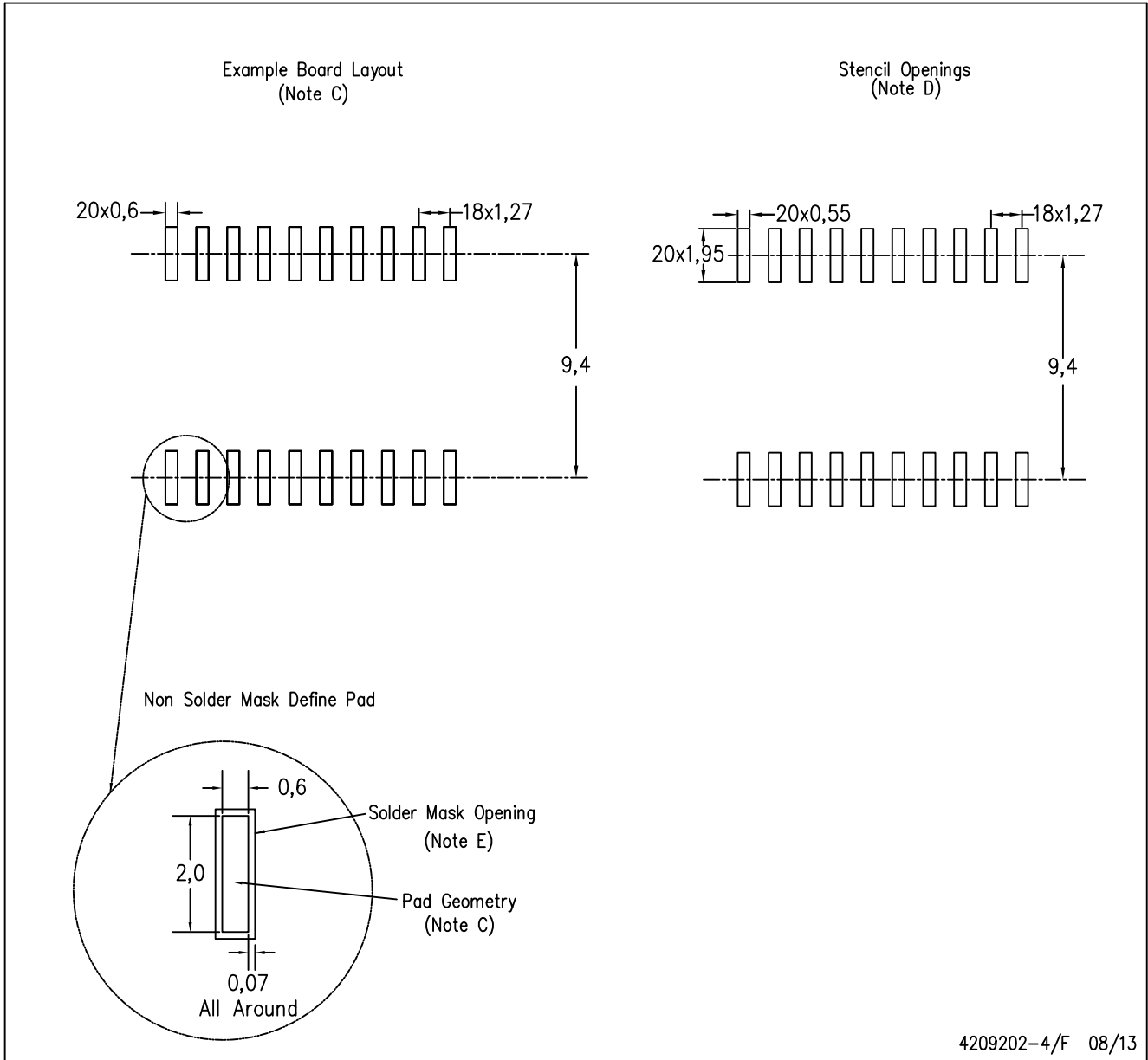

4209202-4/F 08/13

- NOTES:
- A. All linear dimensions are in millimeters.
 - B. This drawing is subject to change without notice.
 - C. Refer to IPC7351 for alternate board design.
 - D. Laser cutting apertures with trapezoidal walls and also rounding corners will offer better paste release. Customers should contact their board assembly site for stencil design recommendations. Refer to IPC-7525
 - E. Customers should contact their board fabrication site for solder mask tolerances between and around signal pads.

IMPORTANT NOTICE

Texas Instruments Incorporated and its subsidiaries (TI) reserve the right to make corrections, enhancements, improvements and other changes to its semiconductor products and services per JESD46, latest issue, and to discontinue any product or service per JESD48, latest issue. Buyers should obtain the latest relevant information before placing orders and should verify that such information is current and complete. All semiconductor products (also referred to herein as "components") are sold subject to TI's terms and conditions of sale supplied at the time of order acknowledgment.

TI warrants performance of its components to the specifications applicable at the time of sale, in accordance with the warranty in TI's terms and conditions of sale of semiconductor products. Testing and other quality control techniques are used to the extent TI deems necessary to support this warranty. Except where mandated by applicable law, testing of all parameters of each component is not necessarily performed.

TI assumes no liability for applications assistance or the design of Buyers' products. Buyers are responsible for their products and applications using TI components. To minimize the risks associated with Buyers' products and applications, Buyers should provide adequate design and operating safeguards.

TI does not warrant or represent that any license, either express or implied, is granted under any patent right, copyright, mask work right, or other intellectual property right relating to any combination, machine, or process in which TI components or services are used. Information published by TI regarding third-party products or services does not constitute a license to use such products or services or a warranty or endorsement thereof. Use of such information may require a license from a third party under the patents or other intellectual property of the third party, or a license from TI under the patents or other intellectual property of TI.

Reproduction of significant portions of TI information in TI data books or data sheets is permissible only if reproduction is without alteration and is accompanied by all associated warranties, conditions, limitations, and notices. TI is not responsible or liable for such altered documentation. Information of third parties may be subject to additional restrictions.

Resale of TI components or services with statements different from or beyond the parameters stated by TI for that component or service voids all express and any implied warranties for the associated TI component or service and is an unfair and deceptive business practice. TI is not responsible or liable for any such statements.

Buyer acknowledges and agrees that it is solely responsible for compliance with all legal, regulatory and safety-related requirements concerning its products, and any use of TI components in its applications, notwithstanding any applications-related information or support that may be provided by TI. Buyer represents and agrees that it has all the necessary expertise to create and implement safeguards which anticipate dangerous consequences of failures, monitor failures and their consequences, lessen the likelihood of failures that might cause harm and take appropriate remedial actions. Buyer will fully indemnify TI and its representatives against any damages arising out of the use of any TI components in safety-critical applications.

In some cases, TI components may be promoted specifically to facilitate safety-related applications. With such components, TI's goal is to help enable customers to design and create their own end-product solutions that meet applicable functional safety standards and requirements. Nonetheless, such components are subject to these terms.

No TI components are authorized for use in FDA Class III (or similar life-critical medical equipment) unless authorized officers of the parties have executed a special agreement specifically governing such use.

Only those TI components which TI has specifically designated as military grade or "enhanced plastic" are designed and intended for use in military/aerospace applications or environments. Buyer acknowledges and agrees that any military or aerospace use of TI components which have **not** been so designated is solely at the Buyer's risk, and that Buyer is solely responsible for compliance with all legal and regulatory requirements in connection with such use.

TI has specifically designated certain components as meeting ISO/TS16949 requirements, mainly for automotive use. In any case of use of non-designated products, TI will not be responsible for any failure to meet ISO/TS16949.

Products

Audio	www.ti.com/audio
Amplifiers	amplifier.ti.com
Data Converters	dataconverter.ti.com
DLP® Products	www.dlp.com
DSP	dsp.ti.com
Clocks and Timers	www.ti.com/clocks
Interface	interface.ti.com
Logic	logic.ti.com
Power Mgmt	power.ti.com
Microcontrollers	microcontroller.ti.com
RFID	www.ti-rfid.com
OMAP Applications Processors	www.ti.com/omap
Wireless Connectivity	www.ti.com/wirelessconnectivity

Applications

Automotive and Transportation	www.ti.com/automotive
Communications and Telecom	www.ti.com/communications
Computers and Peripherals	www.ti.com/computers
Consumer Electronics	www.ti.com/consumer-apps
Energy and Lighting	www.ti.com/energy
Industrial	www.ti.com/industrial
Medical	www.ti.com/medical
Security	www.ti.com/security
Space, Avionics and Defense	www.ti.com/space-avionics-defense
Video and Imaging	www.ti.com/video

TI E2E Community

e2e.ti.com