

F8015AP TYPE

1ボール1スリーブ
(80x80x15mm)

Dimensions: Not to scale

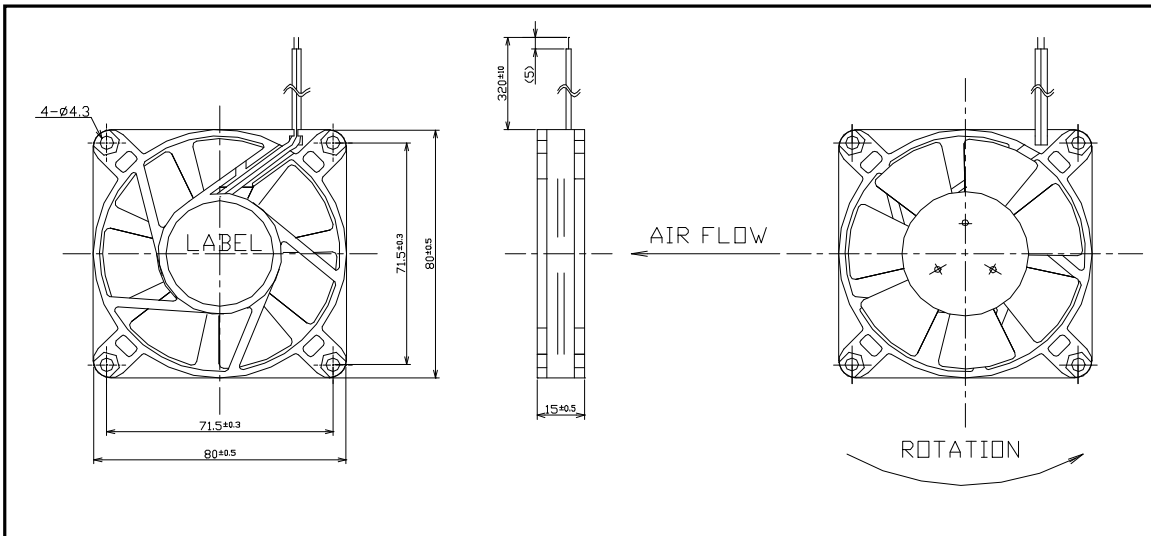

Specifications

機種名 (Model)	F8015AP-12LCW F8015AP-24LCW				
定格電圧 (DCV)	12	24			
Rated voltage					
使用電圧範囲 (DCV)	10.2~13.8	20.4~27.6			
Operating voltage range					
定格電流 (A)	0.2	0.1			
Rated current					
定格入力 (W)	2.4	2.4			
Rated input					
最大風量 (m ³ /min)	0.52	0.52			
Max Air Volume					
最大静圧 (Pa)	27.4	27.4			
Max Static Pressure					
A特性音圧レベル (dB)	32	32			
Noise Lv at 1m (A-weighted)					
回転速度 (min ⁻¹)	3,000	3,000			
Rotation frequency					
期待寿命 (h)			50,000		
Life expectancy ★			Room temp-humidity		

使用温度範囲(Operating temp. range): -10 ~ +60°C ★★

保存温度範囲(Strage temp. range): -40 ~ +70 ★★

リード線(Lead Wire): UL2468 AWG26: {12V: Red(+), Black(-)}, {24V: Red(+), Blue(-)}

重量(Weight): 73g

絶縁抵抗(Insulation resist.): Min 10M Ω at DC500V (Between frame and leadwire)

耐電圧(Voltage withstand): 5mA (AC500V 1minute or AC600V 1 second, between frame and leadwire)

★In room temperature and humidity ★★In room humidity Room temp.=20±15°C, Room humidity=65±20% 0203

Specifications subject to change without notice. Copyright ©2002 Shicoh Engineering Co., Ltd.

<http://www.shicoh.com>

