

EVAL-M1-05-65D

iMOTION™ Modular Application Design Kit

About this document

Scope and purpose

This application note provides an overview of the evaluation-board EVAL-M1-05-65D including its main features, key data, pin assignments and mechanical dimensions.

EVAL-M1-05-65D is a complete evaluation-board including a 3-phase IPM for motor drive application. In combination with either EVAL-M1-1302 or EVAL-M1-099M it features and demonstrates Infineon's IPM technology for motor drive.

The evaluation board EVAL-M1-05-65D for Intelligent Power Modules (IPM) was developed to support customers during their first steps designing applications with μ IPM™ -DIP power modules.

Intended audience

This application note is intended for all technical specialists working with the EVAL-M1-05-65D board.

Table of Contents







About this document.....	1
Table of Contents	1
1 Safety precautions	2
2 Introduction	4
3 Main features	5
3.1 Key data.....	6
4 Pin assignments.....	10
5 Schematics and Layout	12
5.1 DC-Link Voltage Measurement	12
5.2 Thermistor Output	13
5.3 EMI input filter and rectifier circuit.....	13
5.4 Inverter section using μ IPM™ -DIP	14
5.5 Power supply.....	15
5.6 Over current circuit.....	15
5.7 Layout	16
6 Bill of Materials of EVAL-M1-05-65D	18
7 Reference.....	19

Safety precautions

1 Safety precautions

In addition to the precautions listed throughout this manual, please read and understand the following statements regarding hazards associated with development systems.

Table 1 **Precautions**

	<p>Attention: <i>The ground potential of the EVAL-M1-05-65D system is biased to a negative DC bus voltage potential. When measuring voltage waveform by oscilloscope, the scope's ground needs to be isolated. Failure to do so may result in personal injury or death. Darkened display LEDs are not an indication that capacitors have discharged to safe voltage levels.</i></p>
	<p>Attention: <i>EVAL-M1-05-65D system contains DC bus capacitors which take time to discharge after removal of the main supply. Before working on the drive system, wait three minutes for capacitors to discharge to safe voltage levels. Failure to do so may result in personal injury or death. Darkened display LEDs are not an indication that capacitors have discharged to safe voltage levels.</i></p>
	<p>Attention: <i>Only personnel familiar with the drive and associated machinery should plan or implement the installation, start-up and subsequent maintenance of the system. Failure to comply may result in personal injury and/or equipment damage.</i></p>
	<p>Attention: <i>The surfaces of the drive may become hot, which may cause injury.</i></p>
	<p>Attention: <i>EVAL-M1-05-65D system contains parts and assemblies sensitive to Electrostatic Discharge (ESD). Electrostatic control precautions are required when installing, testing, servicing or repairing this assembly. Component damage may result if ESD control procedures are not followed. If you are not familiar with electrostatic control procedures, refer to applicable ESD protection handbooks and guidelines.</i></p>
	<p>Attention: <i>A drive, incorrectly applied or installed, can result in component damage or reduction in product lifetime. Wiring or application errors such as under sizing the motor, supplying an incorrect or inadequate AC supply or excessive ambient temperatures may result in system malfunction.</i></p>
	<p>Attention: <i>Remove and lock out power from the drive before you disconnect or reconnect wires or perform service. Wait three minutes after removing power to discharge the bus capacitors. Do not attempt to service the drive until the bus capacitors have discharged to zero. Failure to do so may result in personal injury or death.</i></p>

Safety precautions



Attention: EVAL-M1-05-65D system is shipped with packing materials that need to be removed prior to installation. Failure to remove all packing materials which are unnecessary for system installation may result in overheating or abnormal operating condition.

Introduction

2 Introduction

The EVAL-M1-05-65D evaluation board is a part of the iMOTION™ Modular Application Design Kit for drives (iMOTION™ MADK).

The MADK-platform is intended to use various power stages with different control boards. These boards can easily be interfaced through the 20 pin iMOTION™ MADK-M1 interface connector.

This evaluation board is designed to give comprehensible solutions of a power stage featuring μ IPM™ -DIP. The board is equipped with all assembly groups for sensor less field oriented control (FOC). It provides a single-phase AC-connector, rectifier, DC-link and 3-phase output for power. It contains emitter-shunts for current sensing and a voltage divider for DC-link voltage measurement.

The EVAL-M1-05-65D evaluation board is available from Infineon. The features of this board are described in the design feature chapter of this document, whereas the remaining paragraphs provide information to enable the customers to copy, modify and qualify the design for production according to their own specific requirements.

Environmental conditions were considered in the design of the EVAL-M1-05-65D. The design was tested as described in this document but not qualified regarding safety requirements or manufacturing and operation over the whole operating temperature range or lifetime. The boards provided by Infineon are subject to functional testing only.

Evaluation boards are not subject to the same procedures as regular products regarding Returned Material Analysis (RMA), Process Change Notification (PCN) and Product Discontinuation (PD). Evaluation boards are intended to be used under laboratory conditions by specialists only.

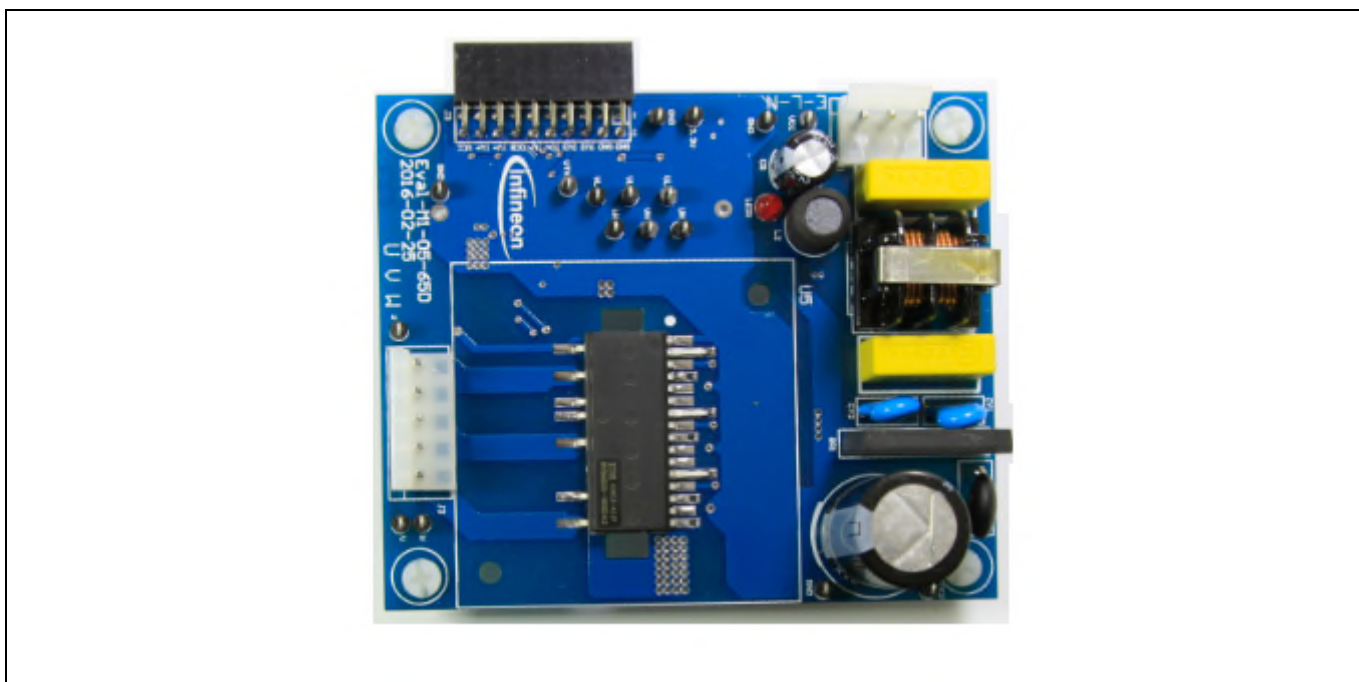

Figure 1 Evaluation-board EVAL-M1-05-65D

Figure 1 shows the evaluation board EVAL-M1-05-65D. Although this board is compatible with on surface mount as well as through whole μ IPM™ -DIP modules. This document explains the features and details of this board in combination with μ IPM™ -DIP IRSM515-065 and IRSM505-065. The only difference between these modules is the presence of a NTC. IRSM505-065 has a NTC and IRSM515-065 does not. Both modules are rated 500 V. Ratings and other details of the board are explained in the subsequent sections.

Main features

3 Main features

EVAL-M1-05-65D is a complete evaluation board including a 3-phase IPM for motor drive application. The kit demonstrates Infineon's IPM technology for motor drives.

Main features of μ IPM™ -DIP Intelligent Power Module IRSM515-065 and IRSM505-065 are:

- 3-phase inverter including high voltage gate drivers
- Integrated bootstrap functionality
- Trench FREDFET with $R_{DS(on)}$ of $1.3 \Omega @ 25^\circ\text{C}$
- Under voltage lockout for all channels
- Matched propagation delay for all channels
- Temperature feedback via NTC applicable for IRSM505-065
- Optimized dV/dt for loss and EMI trade off
- 3.3 V logic compatible and advanced input filter
- Possibility to choose single shunt or emitter shunt current sensing
- Driver tolerant to negative transient voltage
- Isolation 1900 V_{rms}, 1min
- Certified by UL file number E252584

The evaluation board characteristics are:

- Nominal input voltage 240 V_{AC}
- 20 – 150 W motor power range without heatsink
- On board EMI filter
- Current sensing for each phase configured by default
- Over current protection
- Sensing of DC-link voltage
- Thermistor output
- Fault diagnostic output
- Measurement test-points compatible to standard oscilloscope probes
- PCB is 90 x 75 mm and has two layers with 35 μm copper each
- RoHS complaint

Main features

3.1 Key data

Figure 2 provides the overview of the IRSM505-065 and IRSM515-065 internal electrical schematics. For further information regarding these IPMs like static and dynamic electrical behavior, as well as thermal and mechanical characteristics please refer to the datasheet of the IRSM505-065 or IRSM515-065. Table 2 provides the absolute maximum ratings of the IRSM505-065 or IRSM515-065.

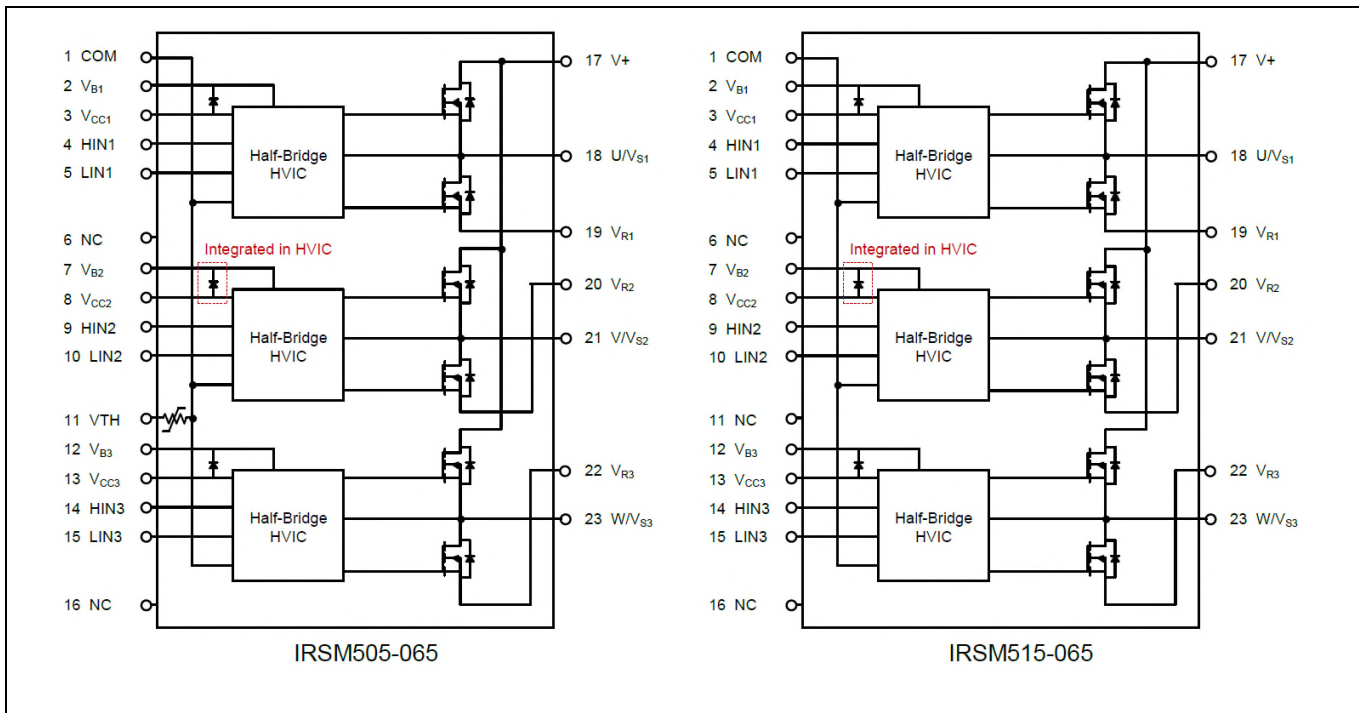

Figure 2 μ IPM™ -DIP internal electrical schematic

Table 2 μ IPM™ -DIP Absolute Maximum Ratings of IRSM505-065 or IRSM515-065 ¹

Symbol	Description	Min	Max	Unit
V_{DSS}	MOSFET Blocking Voltage	---	500	V
$I_o @ T=25^\circ C$	DC Output Current per MOSFET	---	2.6	A
$P_d @ T_C=25^\circ C$	Maximum Power Dissipation per MOSFET	---	19	W
V_{ISO}	Isolation Voltage (1min)	---	1900	V_{rms}
T_J	Operating Junction Temperature	-40	150	$^\circ C$
T_C	Operating Case Temperature	-40	150	$^\circ C$
T_S	Storage Temperature	-40	150	$^\circ C$
$V_{S1,2,3}$	High Side Floating Supply Offset Voltage	$V_{B1,2,3} - 20$	$V_{B1,2,3} + 0.3$	V
$V_{B1,2,3}$	High Side Floating Supply Voltage	-0.3	275	V
V_{CC}	Low Side and Logic Supply voltage	-0.3	25	V
V_{IN}	Input Voltage of LIN, HIN	-0.3	$V_{CC} + 0.3$	V

1. Absolute maximum ratings are limitations which should not be less than minimum or higher than maximum ratings. Outside these limitations for safe operation, damage of the module should be expected.

Main features

Table 3 depicts the recommended operating conditions of IRSM505-065 or IRSM515-065.

Table 3 Recommended operating conditions of μ IPM™ -DIP IRSM505-065 or IRSM515-065

Symbol	Description	Min	Max	Unit
V+	Positive DC Bus Input Voltage	$2 \cdot V_{CC} + 5$	400	V
V _{S1,2,3}	High Side Floating Supply Offset Voltage	---	400	V
V _{B1,2,3}	High Side Floating Supply Voltage	V _{Sx} +12	V _{Sx} +20	V
V _{CC}	Low Side and Logic Supply Voltage	13.5	16.5	V
V _{IN}	Input Voltage of LIN, HIN, I _{TRIP} , EN, FLT	0	5	V
f _{SW}	PWM Carrier Frequency	---	20	kHz

Main features

Table 4 shows the important specifications of the evaluation board EVAL-M1-05-65D.

Table 4 EVAL-M1-05-65D board specifications

Parameters	Value	Conditions
Input		
Voltage	100-240 V _{rms}	
Frequency	50/60 Hz	
Input current	1.5 A _{rms}	IRSM505-065DA/ IRSM515-065DA, module T _c = 70°C without heatsink
Output		
Power (3phases)	90 W**	IRSM505-065DA/ IRSM515-065DA
Current per leg	650 mA*	IRSM505-065DA/ IRSM515-065DA
	*rms, f _{PWM} =6 kHz, T _a =25°C, **input 220V _{AC} , T _c =125°C, */**without heatsink	
DC Bus		
Maximum DC bus voltage	400 V	
Minimum DC bus voltage	110 V	
Current feedback		
Current sensing devices RS1, RS2, RS3	0.25 Ω	The default configuration uses three shunts in the emitter paths. To implement single shunt sensing, RS1 and RS3 have to be removed IU+,IV+,IW+ have to be connected, R7 has to be changed to 3.48 kΩ
Protections		
Output current trip level	2.5A _{pk}	Configured by either changing shunt resistors RS1, RS2, RS3 or adapting comparator threshold changing resistor R7
On board power supply		
15 V	15 V±5 %, Max 20 mA	Used for μIPM™ -DIP gate driver power
3.3 V	3.3 V±5 %, Max 50 mA	Used for interface signals to the control board and alarm signals as I _{TRIP} , FLT/EN
PCB characteristics		
Material	FR4, 1.6 mm thickness, 2-layers. 35 μm copper thickness	
Dimension	90 mm x 75 mm	
System environment		
Ambient temperature	From 0 to 70°C	Non-condensing, maximum RH of 95 %

Main features

Figure 3 and Figure 4 hint out the functional groups of the EVAL-M1-05-65D evaluation board.

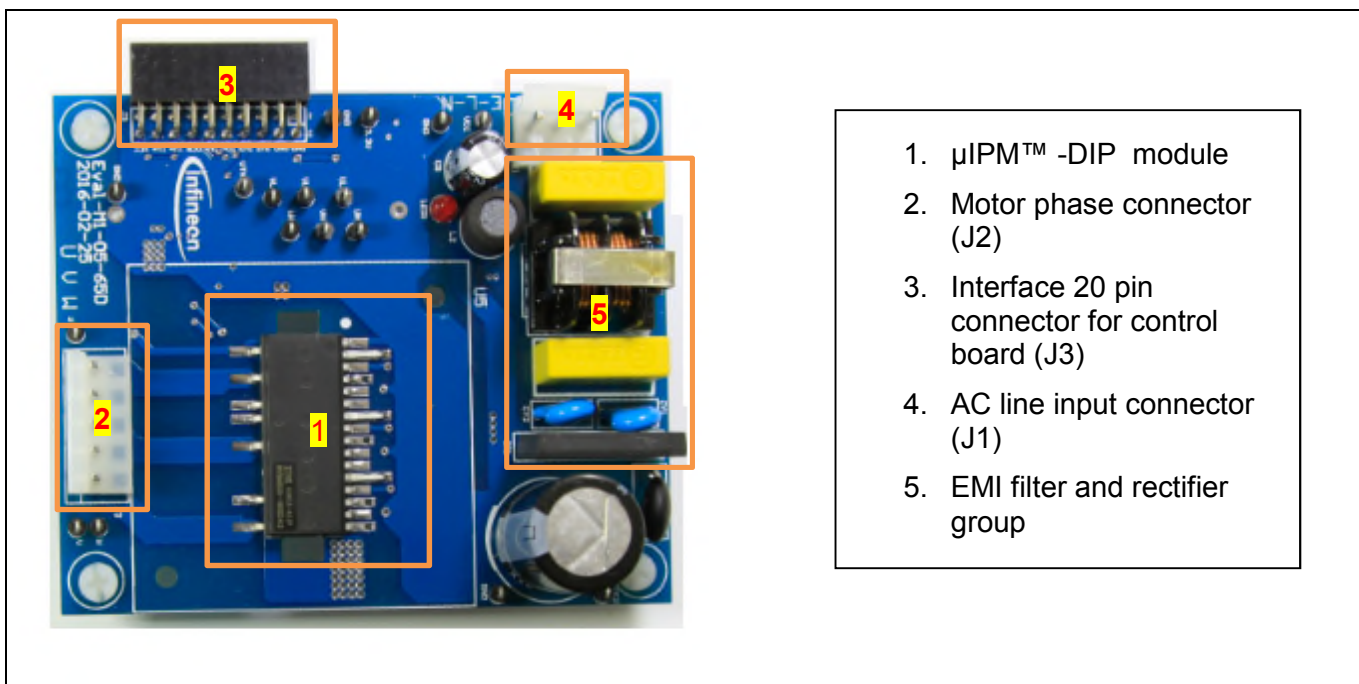

1. μ IPM™ -DIP module
2. Motor phase connector (J2)
3. Interface 20 pin connector for control board (J3)
4. AC line input connector (J1)
5. EMI filter and rectifier group

Figure 3 Functional groups of the EVAL-M1-05-65D evaluation board's top side

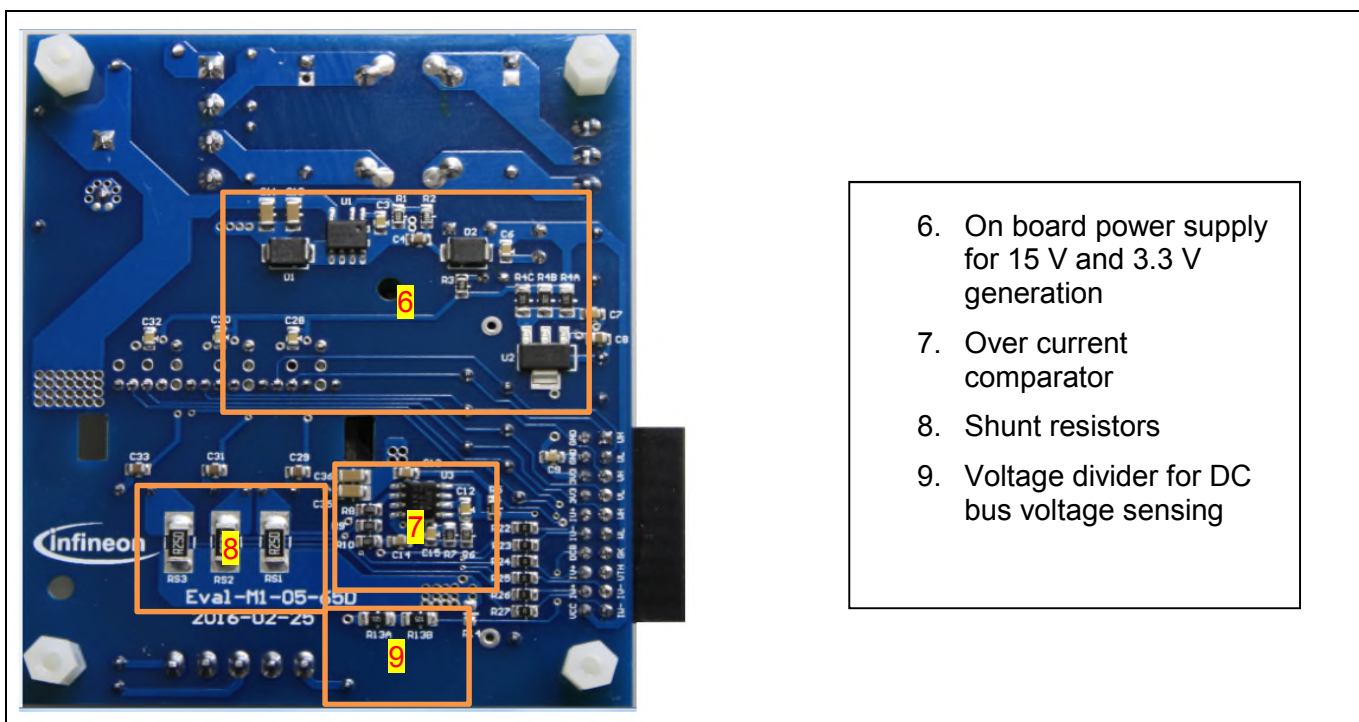

6. On board power supply for 15 V and 3.3 V generation
7. Over current comparator
8. Shunt resistors
9. Voltage divider for DC bus voltage sensing

Figure 4 Functional groups of the EVAL-M1-05-65D evaluation board's bottom side

Pin assignments

4 Pin assignments

General information about the connectors of the EVAL-M1-05-65D evaluation board is reported. Table 5 includes the details of the line connector J1-AC. It is possible to connect DC voltage to the AC connector. In this case a permanent DC-current will be conducted through the rectifier bridge. Maximum ratings are valid for AC as well as DC conditions. It is recommended to observe the temperature of the rectifier bridge. Due to the rectifier, DC supply's polarity at the connector is of no concern.

The evaluation board doesn't have a fuse. An external fuse is highly recommended during testing.

Table 5 J1- AC Line connector

S. No.	Pin	Details
1	ETH	Earth ground
2	L	AC line input (120 V – 240 V) or DC+ connector
3	N	AC neutral input or DC- connector

Table 6 denotes the details of the motor side connector J2.

Table 6 J2- Motor side connector

S. No.	Pin	Details
1	U	Connected to motor phase U
2	V	Connected to motor phase V
3	W	Connected to motor phase W

Pin assignments

Table 7 provides the pin assignments of the M1 20 pin interface connector J3. This connector is the interface to the controller board.

Table 7 J3 - 20 pin interface connector for controller board

Pin	Name	Connectors
1	PWMUH	3.3 V compatible logic input for high side gate driver-Phase1 ²
2	GND	Ground
3	PWMUL	3.3 V compatible logic input for low side gate driver-Phase1 ²
4	GND	Ground
5	PWMVH	3.3 V compatible logic input for high side gate driver-Phase2 ²
6	+3.3V	On board 3.3 V supply
7	PWMVL	3.3 V compatible logic input for low side gate driver-Phase2 ²
8	+3.3V	On board 3.3 V supply
9	PWMWH	3.3 V compatible logic input for high side gate driver-Phase3 ²
10	IU+	Shunt voltage phase U
11	PWMWL	3.3 V compatible logic input for low side gate driver-Phase3 ²
12	IU-	Ground
13	GK	Gate kill signal – active low when over current is detected ³
14	DCBSENSE	DC bus positive voltage, scaled in 0-3.3 V range by a voltage divider
15	VTH	Thermistor Output
16	IV+	Shunt voltage phase V
17	IV-	Ground
18	IW+	Shunt voltage phase W
19	IW-	Ground
20	VCC	15 V Supply

2. *Input signals are active high. Pull-down resistors are not inserted on the EVAL-M1-05-65D board and need to be assembled on control cards. iMOTION™ MADK control cards are already equipped with pull-down resistors.*
3. *Gate Kill signal (GK) is pulled low during over current condition. Chapter 5.6 explains the details of this circuit.*

5 Schematics and Layout

To meet individual customer requirements and make the EVAL-M1-05-65D evaluation board a basis for development or modification, all necessary technical data like schematics, layout and components are included in this chapter.

5.1 DC-Link Voltage Measurement

Pin 14 of connector J3 provides access to the DC-link voltage. Three possible feedback cases are associated with this pin. Figure 5 provides the DC bus sense resistor details.

By default, R14 is not mounted on Eval-M1-05-65D. There must be a pull-down resistor mounted on the corresponding control card.

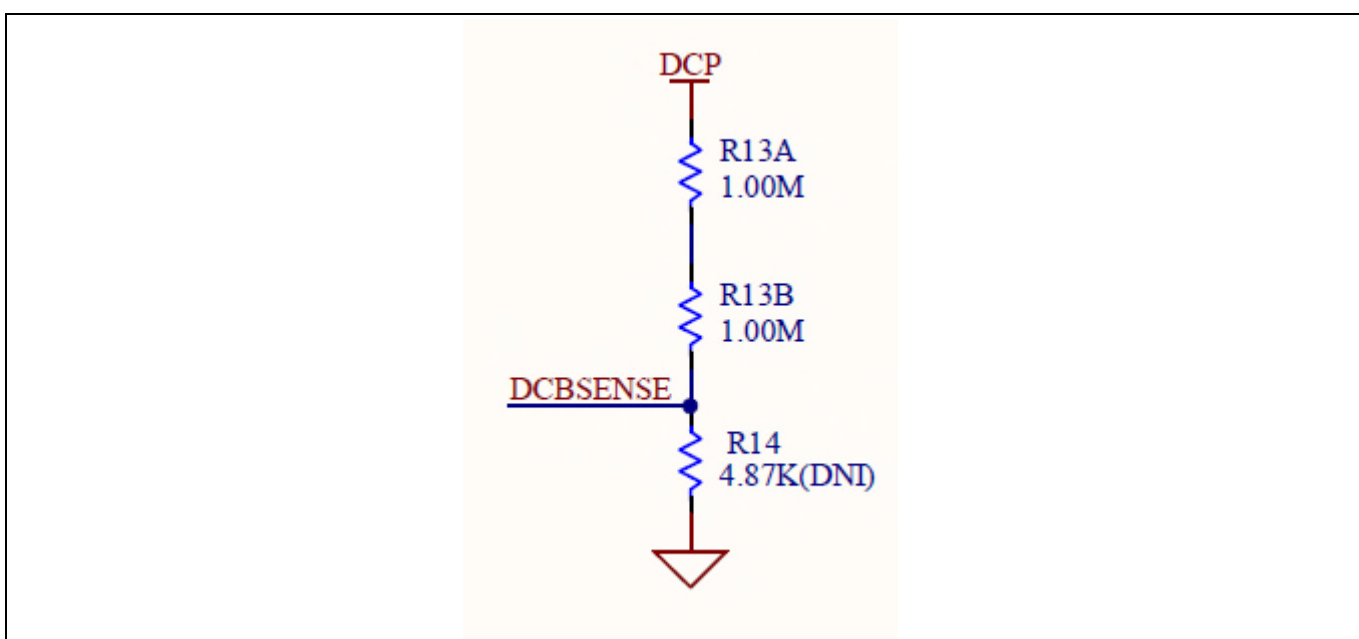

Figure 5 DC bus sense resistor on EVAL-M1-05-65D evaluation board

If a pull down resistor of 4.87 k Ω referred to ground is inserted either on the Eval-M1-05-65D evaluation board or on the control board, the DCBSENSE voltage results in the range of 0 to 3.3 V on the pin reflecting a DC bus voltage range of 0 to 400 V.

If a pull down resistor of 4.87 k Ω is inserted on both, Eval-M1-05-65D evaluation board and on the control card, the DCBSENSE results scale to 0-1.65 V. No safety issue occurs.

If no feedback is desired on the DCBSENSE-pin, R13A or R13B should be removed to avoid high voltage on the connector.

5.2 Thermistor Output

This board provides Thermistor/NTC- output on pin 15 of the 20 pin connector J3. Temperatures can be calculated by resistor measurement. Within the μ IPM™ -DIP datasheet, thermistor details are listed as summarized in Table 8. There is additional information in the datasheet of IRSM505-65D about how to use the NTC.

Table 8 Internal NTC – Thermistor Characteristics (IRSM505-065 Only)

Symbol	Description	Min	Typ	Max	Units	Conditions
R25		-	47	-	k Ω	T _C =25°C, \pm 5% tolerance
R125		-	1.41	-	k Ω	T _C =125°C
B		-	4050	-	K	\pm 2% tolerance
Temperature Range		-40		120	°C	

5.3 EMI input filter and rectifier circuit

Figure 6 depicts the schematic from the AC line input connector J1 to the rectified DC bus voltage. This circuitry includes a passive EMI filter consisting of elements CX1, CX2, L1, CY1 and CY2, a 4 A/600 V rectifier block BR1 and a NTC resistor RT1 for surge current protection. An electrolytic capacitor C1 and two ceramic capacitors C10 and C11 are used for buffering the rectified DC bus voltage DCP. During testing it is advisable to include an external fuse.

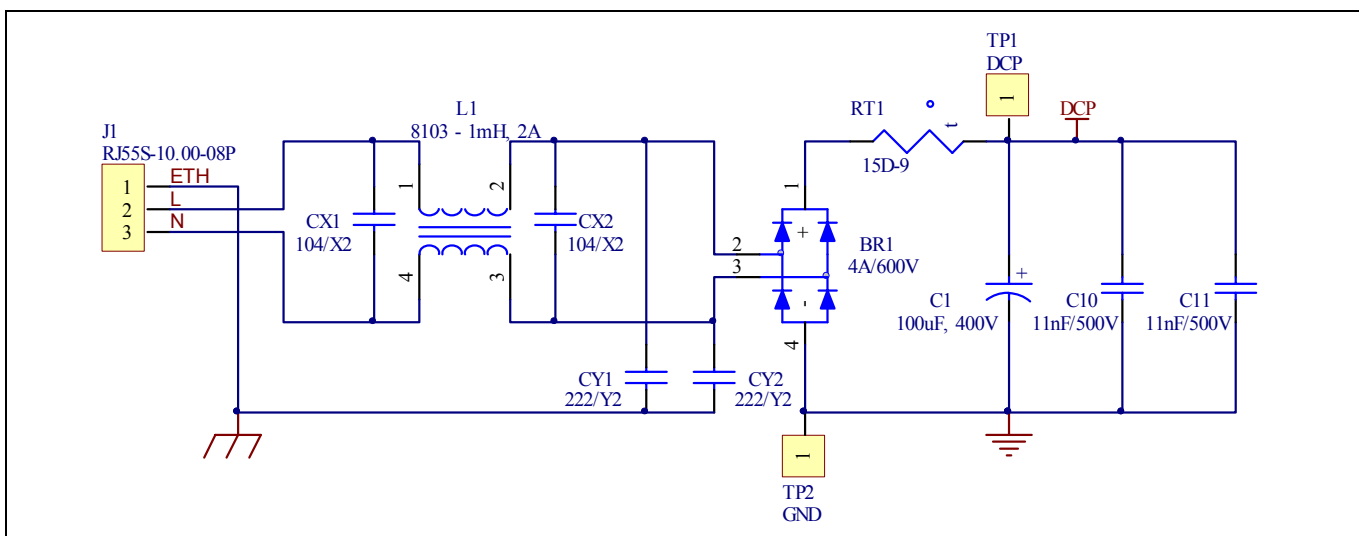

Figure 6 Schematic for EMI input filter and AC/DC section of the EVAL-M1-05-65D evaluation board

5.4 Inverter section using μ IPM™ -DIP

The inverter section is implemented using the μ IPM™ -DIP IPM as sketched in Figure 7. The module includes six power MOSFETs and three half bridge gate drivers. The shunt resistor section is also given, including the 0 Ω resistors R22 to R27. These resistors allow connecting or disconnecting the shunts' signals to connector J3. The three capacitors C29, C31 and C33 are used as bootstrap capacitors to provide the necessary floating supply voltages V_{BS1} , V_{BS2} and V_{BS3} respectively.

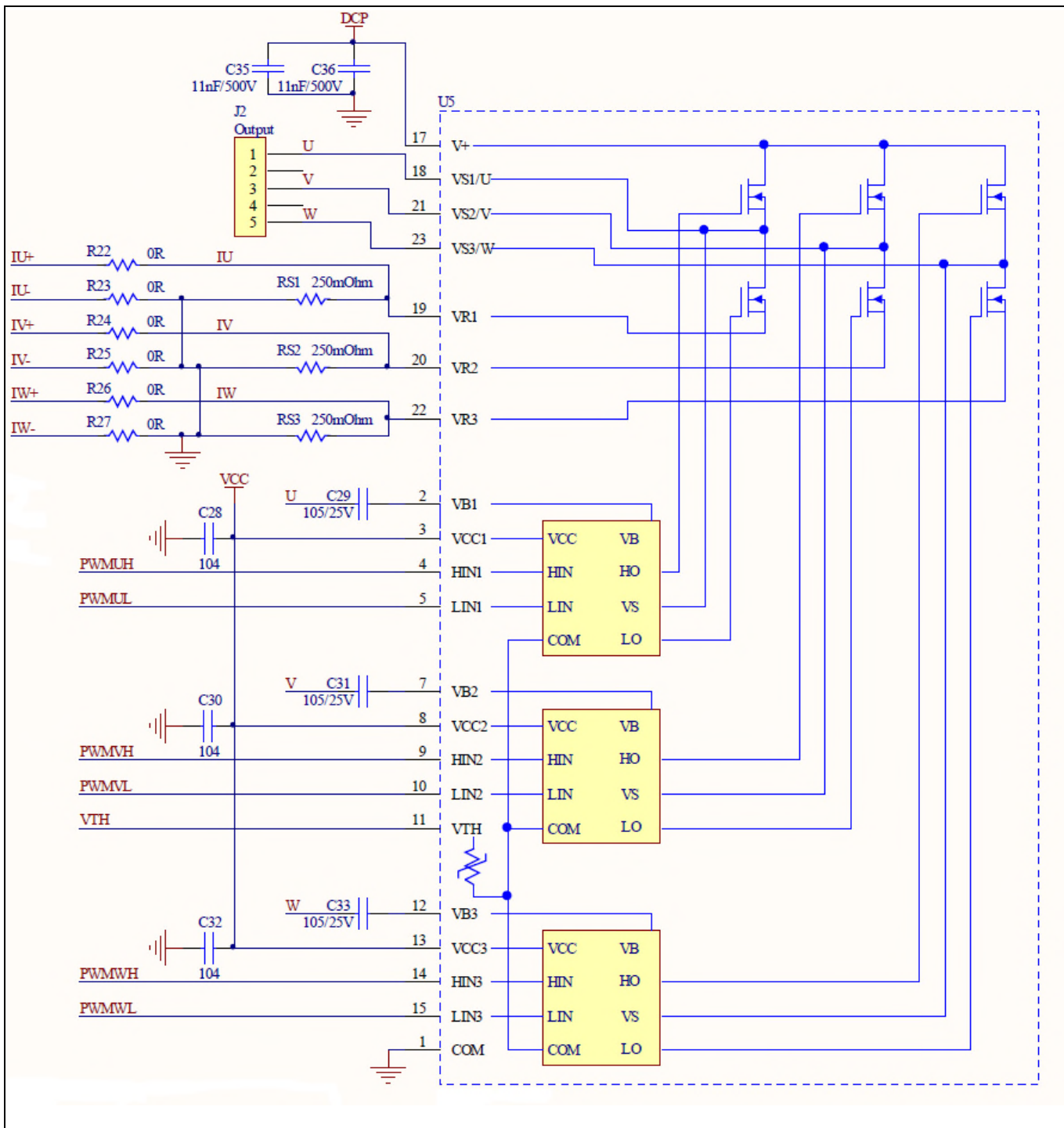

Figure 7 Schematic of the 3-phase inverter section using μ IPM™ -DIP on EVAL-M1-05-65D evaluation board

Schematics and Layout

5.5 Power supply

Figure 8 depicts the schematic of the power supply available on the EVAL-M1-05-65D board. The circuit includes a LNK304 that is used to generate 15 V (V_{CC}) directly from the DC bus. V_{CC} is connected to the gate drivers inside the μ IPM™ -DIP.

The linear regulator LD1117S33 generates 3.3 V from V_{CC} . The 3.3 V power supply is used in the over current comparator circuit. Led LED1 is used to signal whether the board is powered or not. Both, V_{CC} and 3.3 V are also present on the 20 pin interface connector J3 to power circuitry on the controller board.

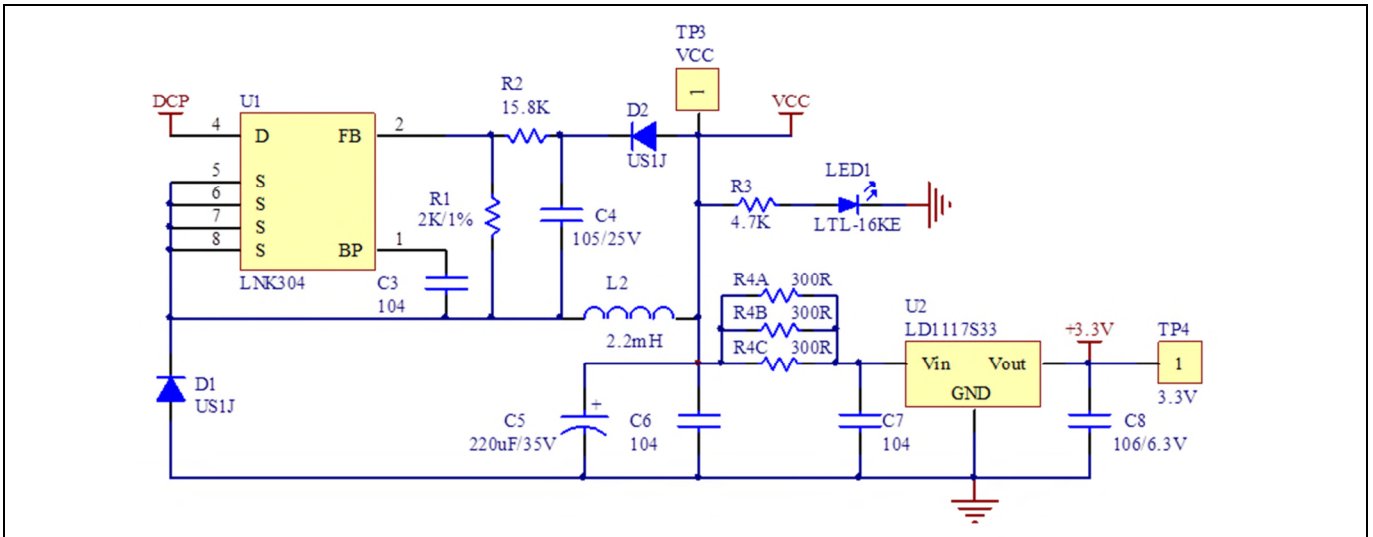

Figure 8 Power supply section of the EVAL-M1-05-65D evaluation board

5.6 Over current circuit

Figure 9 displays the over current protection circuitry. The open collector output GK of the comparator is pulled up to 3.3 V and filtered through resistor R5 and capacitor C13.

The comparator threshold can be set through the voltage divider provided by resistors R6 and R7. By default for emitter shunt trip, R7 is 1k Ω . In single shunt application R7 needs to be changed to 3.48k Ω .

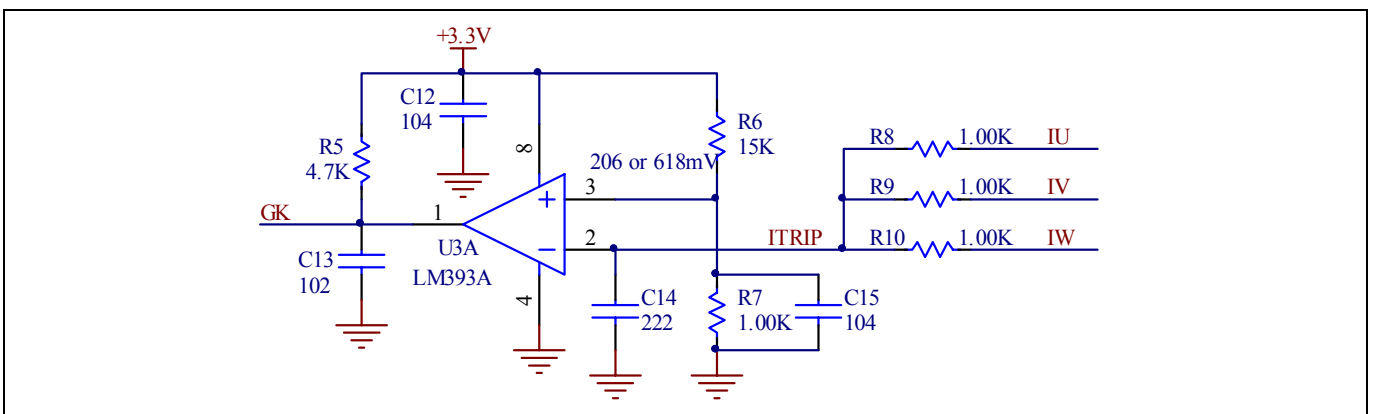

Figure 9 Over current protection circuit on the EVAL-M1-05-65D evaluation board

Schematics and Layout

5.7 Layout

The layout of this board can be used for different voltage or power classes. The power PCB is a two layer PCB. Get in contact with our technical support team to get more detailed information and the latest Gerber-files.

Figure 10 illustrates the top assembly print of the evaluation board.

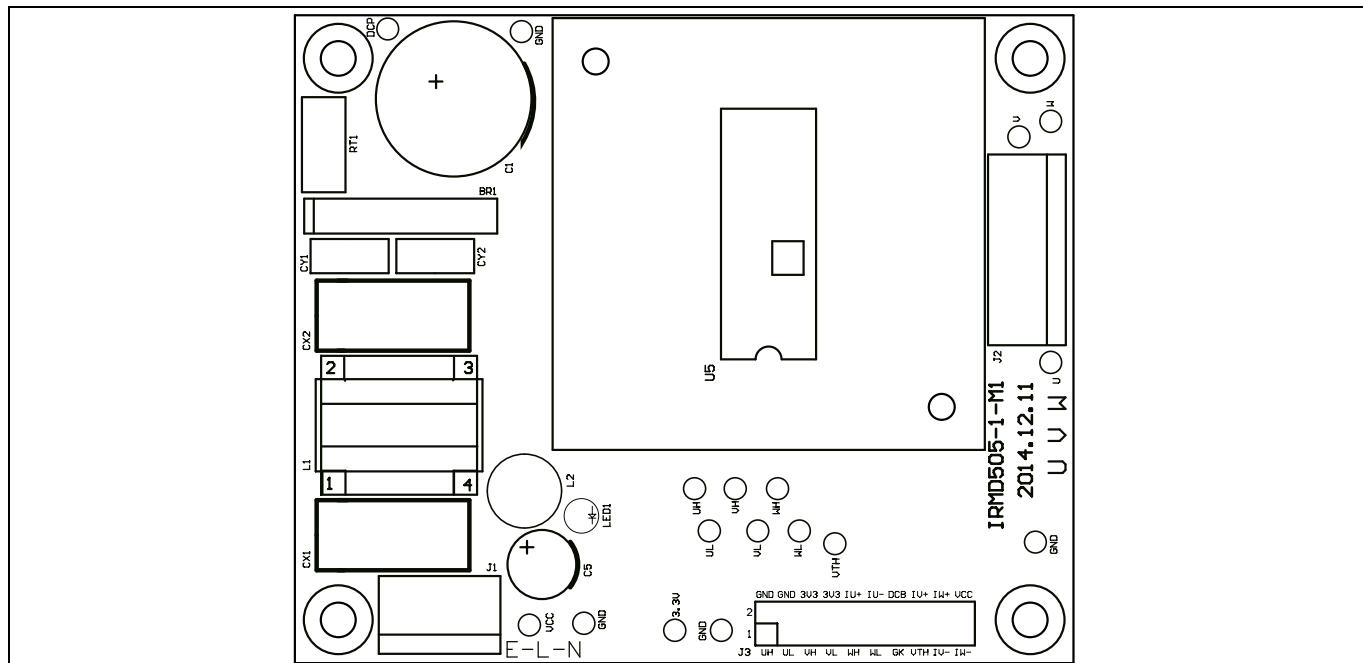

Figure 10 Top assembly print of the EVAL-M1-05-65D evaluation board

Figure 11 depicts the bottom assembly print of the evaluation board.

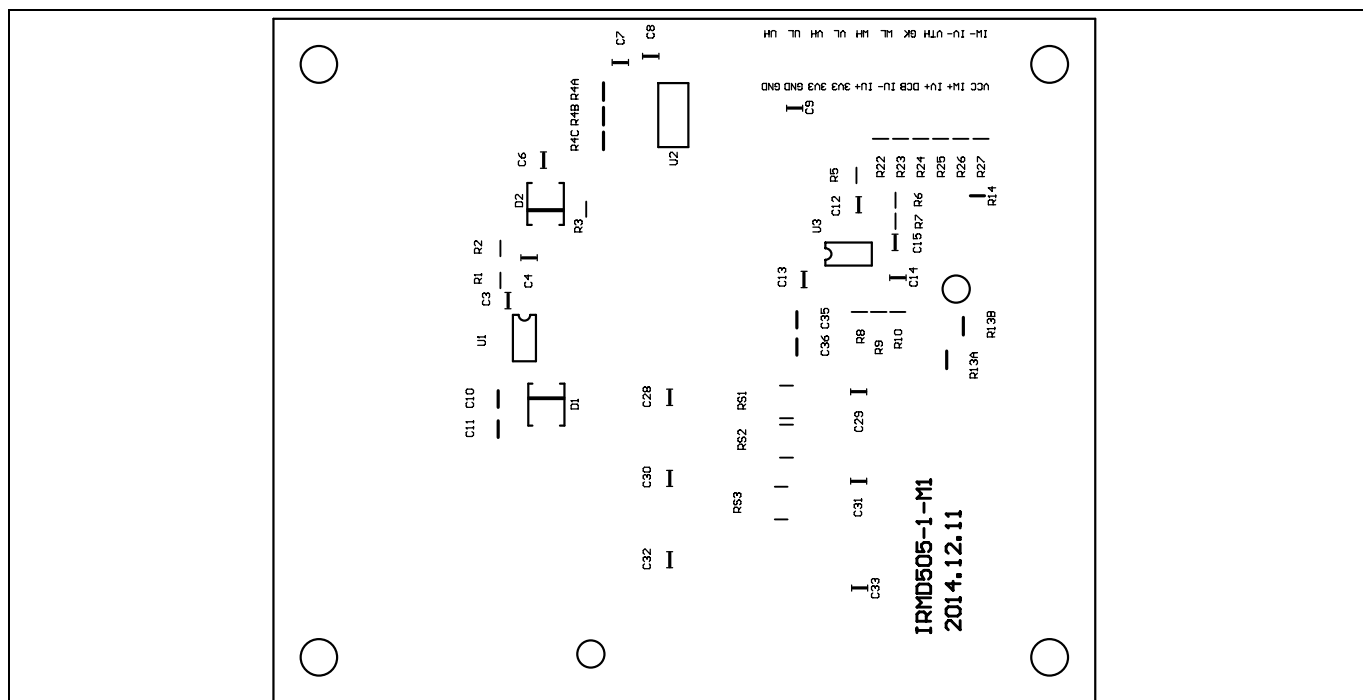

Figure 11 Bottom assembly print of the EVAL-M1-05-65D evaluation board

The top layer of the PCB is provided in Figure 12.

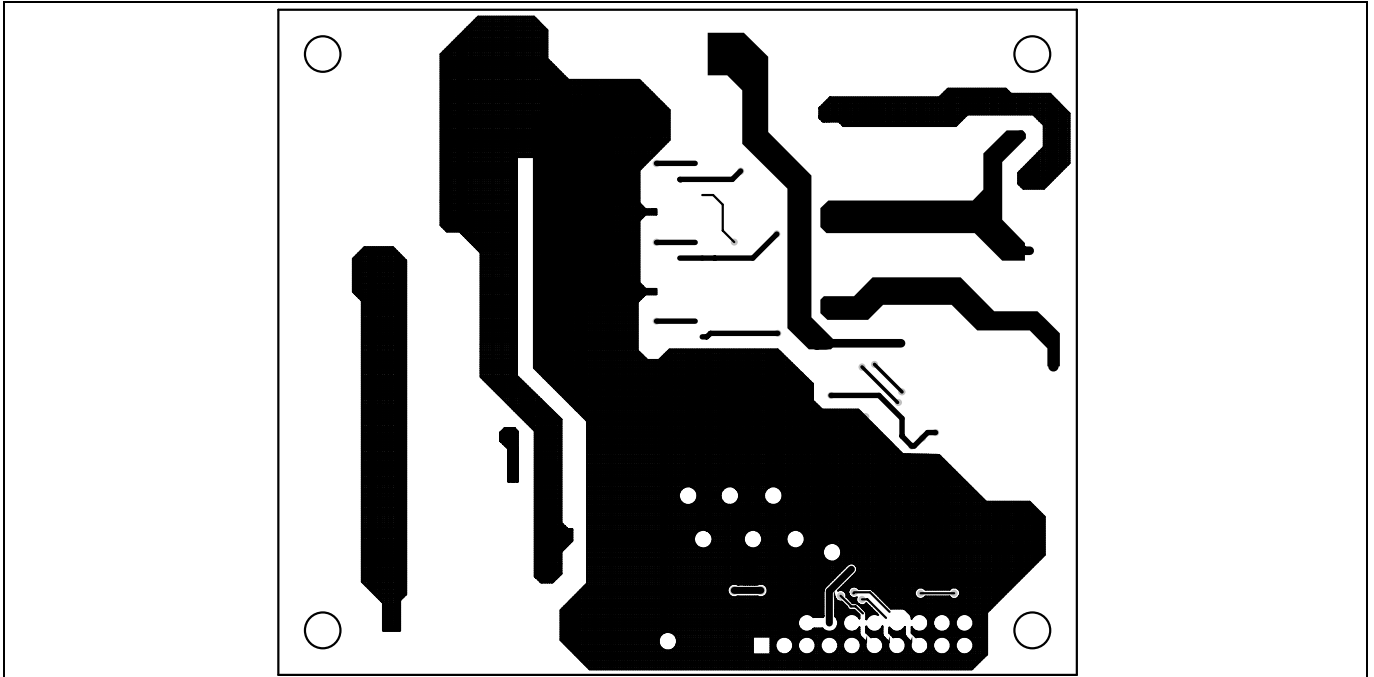

Figure 12 Top layer of the EVAL-M1-05-65D

Figure 13 illustrates the bottom layer routing of the PCB.

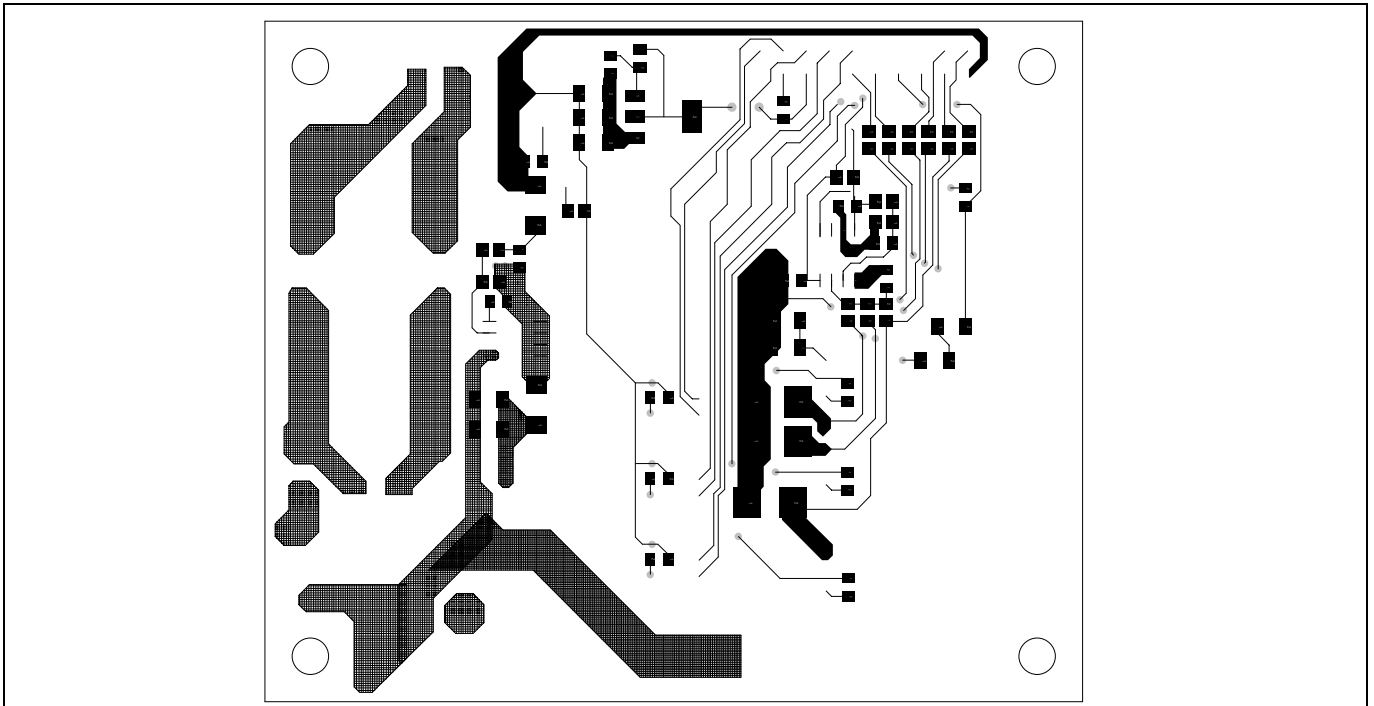

Figure 13 Bottom layer routing of the EVAL-M1-05-65D

6 Bill of Materials of EVAL-M1-05-65D

Table 9 provides the complete bill of materials of the evaluation board.

Table 9 Bill of materials

S.No	Designator	Part description	Part number	Manufacturer
1	BR1	RECT BRIDGE GPP 4A 600V GBU	GBU406	DIODES INCORPORAT ED
2	C1	CAP ALUM 100µF 20% 200V RADIAL	200TXW100MEFC1 8X30	RUBYCON
3	C3, C6, C7, C9, C12, C15, C28, C30, C32	CAP CER 0.1µF 50V X7R 0805	08055C104KAT2A	AVX CORPORATIO N
4	C4, C29, C31, C33	CAP CER 1µF 25V X7R 0805	CL21B105KAFNN E	SAMSUNG ELECTRO- MECHANICS AMERICA,INC.
5	C5	CAP ALUM 220µF 20% 35V RADIAL	35ZLH220MEFC8X 11.5	RUBYCON
6	C8	CAP CER 10µF 6.3V X7R 0805	CL21B106KQQNN E	SAMSUNG ELECTRO- MECHANICS AMERICA,INC.
7	C10, C11, C35, C36	CAPACITOR, CERAMIC, MULTILAYER, 250 V, X7R, 0.011µF, SURFACE MOUNT, 1206	1206B113K501NT	NOVACAP
8	C13	CAP CER 1000pF 50V X7R 0805	C0805C102K5RAC TU	KEMET
9	C14	CAP CER 2200pF 50V X7R 0805	08055C222KAT2A	AVX CORPORATIO N
10	CX1, CX2	CAP FILM 0.1µF 20% 275VAC RADIAL	PME271MB6100MR 30	KEMET
11	CY1, CY2	CAP CER 2200pF 250VAC RADIAL	DE2E3KY222MN3A M02F	MURATA ELECTRONIC S
12	D1, D2	DIODE GEN PURP 600V 1A SMB	MURS160-13-F	DIODES INCORPORAT ED
13	J1	3 Positions Header, Unshrouded Connector 3.96mm	26604030	MOLEX,LLC
14	J2	5 Positions Header, Unshrouded Connector 3.96mm	26604050	MOLEX,LLC
15	J3	20 Position Header Connector 2.54mm	PPTC102LJBN-RC	SULLINS CONNECTOR SOLUTIONS
16	L1	??	150µH/EMI inductor	

Reference

17	L2	Inductor	2.2mH/Filter inductor	Customized
18	LED1	LED RED DIFF 3MM ROUND T/H	LTL-16KE	LITE-ON
19	R1	RES 0805 2kΩ 1%	0805F2001T5E	UNIOHM
20	R2	RES 0805 15.8k 1%	0805F1582T5E	UNIOHM
21	R3, R5	RES 0805 4.7kΩ 1%	0805J0472T5E	UNIOHM
22	R4A, R4B, R4C	RES 1206 300Ω 5%	1206J0301T5E	UNIOHM
23	R6	RES 0805 15kΩ 1%	0805J0153T5E	UNIOHM
24	R7, R8, R9, R10	RES 0805 1kΩ 1%	0805J0102T5E	UNIOHM
25	R13A, R13B	RES 1206 1MΩ 5%	1206J0105T5E	UNIOHM
26	R14 (DNP)	RES 0805 4.87kΩ 1%	0805F4871T5E	UNIOHM
27	R22, R23, R24, R25, R26, R27	RES 0805 0Ω 1%	0805J0R00T5E	UNIOHM
28	RS1, RS2, RS3	RES 2010 0.25Ω	2010J0R25T5E	UNIOHM
29	RT1	NTC 15Ω 9MM DIA	NTC15D-9	SHIN-HANG
30	TP1, TP2, TP22, TP23, TP24, TP3, TP4, TP7, TP13, TP14, TP15, TP16, TP17, TP18, TP19, TP20, TP21	TEST POINT PC MINI .040"D WHITE	2502	KEYSTONE ELECTRONICS
31	U1	IC OFFLINE SWITCHER	LNK304DN-TL	POWER INTEGRATION S
32	U2	IC REG LDO 3.3V 0.8A SOT223	LD1117S33TR	ST MICRO-ELECTRONICS
33	U3	IC DUAL DIFFERENTIAL COMPARATOR	LM393ADR	TI
34	U5	IC MOTOR DRIVER 500V DIP 23	IRSM515-065 / IRSM505-065	INFINEON TECHNOLOGIES

7 Reference

- [1] Datasheet of Infineon IPM IRSM505-065, is available for download on Infineon's website
- [2] Application Note AN2009-10
Using the NTC inside a power electronic module, is available for download on Infineon's website



Table of Contents

Page or Reference	Description of change

Trademarks of Infineon Technologies AG

μ HVIC™, μ IPM™, μ PFC™, AU-ConvertIR™, AURIX™, C166™, CanPAK™, CIPOS™, CIPURSE™, CoolDP™, CoolGaN™, COOLiR™, CoolMOS™, CoolSET™, CoolSiC™, DAVE™, DI-POL™, DirectFET™, DrBlade™, EasyPIM™, EconoBRIDGE™, EconoDUAL™, EconoPACK™, EconoPIM™, EiceDRIVER™, eupec™, FCOS™, GaNpowIR™, HEXFET™, HITFET™, HybridPACK™, iMOTION™, IRAM™, ISOFACE™, IsoPACK™, LEDriviR™, LITIX™, μ IPM™, MIPAQ™, ModSTACK™, my-d™, NovalithiC™, OPTIGA™, OptiMOS™, ORIGA™, PowIRaudio™, PowIRStage™, PrimePACK™, PrimeSTACK™, PROFET™, PRO-SiL™, RASIC™, REAL3™, SmartLEWIS™, SOLID FLASH™, SPÖC™, StrongIRFET™, SuplIRBuck™, TEMPFET™, TRENCHSTOP™, TriCore™, UHVIC™, XHP™, XMC™

Trademarks updated November 2015

Other Trademarks

All referenced product or service names and trademarks are the property of their respective owners.

Edition 2016-08-18

Published by

**Infineon Technologies AG
81726 Munich, Germany**

**© 2016 Infineon Technologies AG.
All Rights Reserved.**

Do you have a question about this document?

Email: erratum@infineon.com

**Document reference
AN2016-24 EVAL-M1-05-65D**

IMPORTANT NOTICE

The information contained in this application note is given as a hint for the implementation of the product only and shall in no event be regarded as a description or warranty of a certain functionality, condition or quality of the product. Before implementation of the product, the recipient of this application note must verify any function and other technical information given herein in the real application. Infineon Technologies hereby disclaims any and all warranties and liabilities of any kind (including without limitation warranties of non-infringement of intellectual property rights of any third party) with respect to any and all information given in this application note.

The data contained in this document is exclusively intended for technically trained staff. It is the responsibility of customer's technical departments to evaluate the suitability of the product for the intended application and the completeness of the product information given in this document with respect to such application.

For further information on the product, technology, delivery terms and conditions and prices please contact your nearest Infineon Technologies office (www.infineon.com).

Please note that this product is not qualified according to the AEC Q100 or AEC Q101 documents of the Automotive Electronics Council.

WARNINGS

Due to technical requirements products may contain dangerous substances. For information on the types in question please contact your nearest Infineon Technologies office.

Except as otherwise explicitly approved by Infineon Technologies in a written document signed by authorized representatives of Infineon Technologies, Infineon Technologies' products may not be used in any applications where a failure of the product or any consequences of the use thereof can reasonably be expected to result in personal injury.