

15回転型 サーマットトリマ
15 TURNS CERMET TRIMMERS

RJC094シリーズ RJC097シリーズ

■特徴

FEATURES

- 微調整が容易
- 設定性及び設定安定性の優れた貴金属合金マルチ接点ワイパー採用
- 密封構造につき各種洗浄液による洗浄可能
- 15-turn design for more accurate adjustment.
- High setting stability with precious metal, multi contact wiper design.
- Sealed to withstand immersion cleaning processes with various cleaning agent.

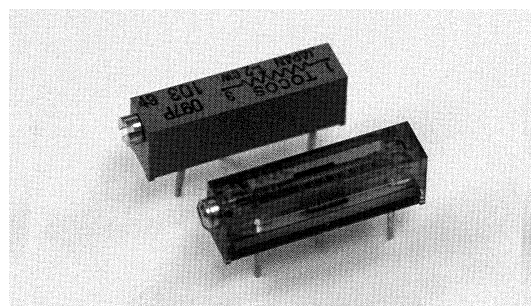

RoHS 指令対応 RoHS compliant

■品名構成

PART NUMBER COMPOSITION

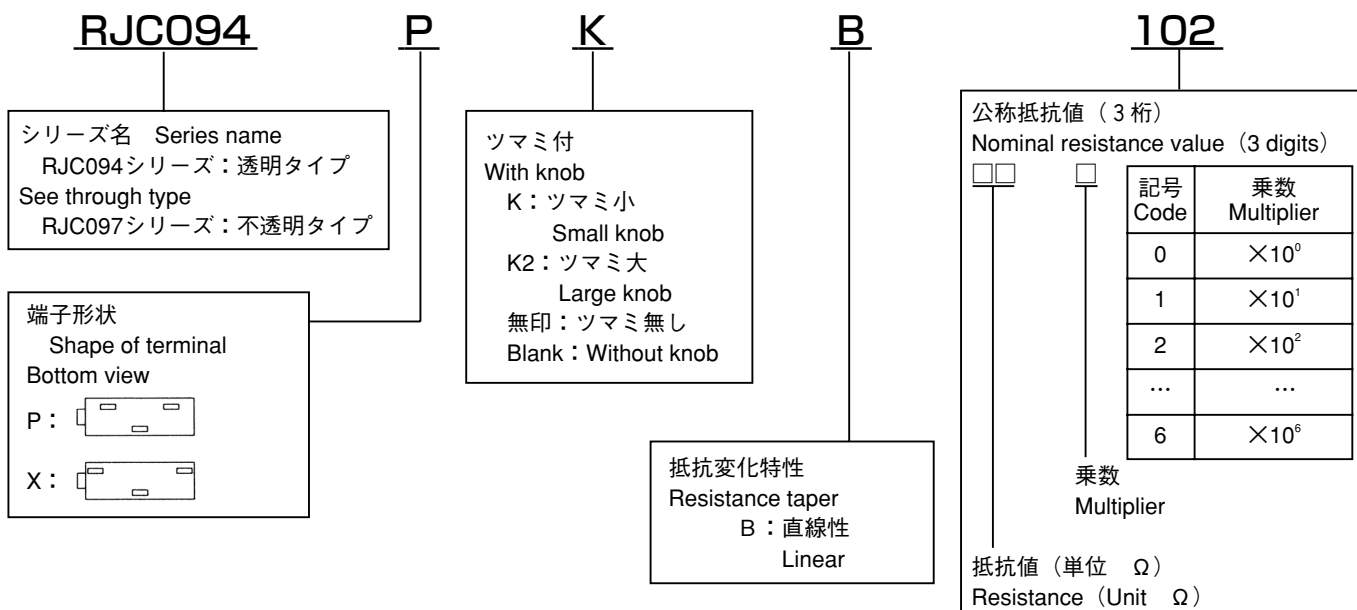

《標準公称抵抗値》
(Nominal resistance value)

公称抵抗値 Nominal resistance value	記号 Code	公称抵抗値 Nominal resistance value	記号 Code	公称抵抗値 Nominal resistance value	記号 Code
10 Ω	100	20 Ω	200	50 Ω	500
100 Ω	101	200 Ω	201	500 Ω	501
1 k Ω	102	2 k Ω	202	5 k Ω	502
10 k Ω	103	20 k Ω	203	50 k Ω	503
100 k Ω	104	200 k Ω	204	500 k Ω	504
1M Ω	105	—	—	—	—

Fig-1

※ご注文に際しては、両シリーズ (RJC094、RJC097) とともに《標準公称抵抗値》Fig-1についてすべての組み合わせが可能です。
※ご注文に際しては、上記品名構成をご確認ください。

■電気的特性

ELECTRICAL CHARACTERISTICS

全抵抗値範囲 Total resistance range	10Ω～1MΩ
全抵抗値許容差 Total resistance tolerance	±20% (±10%)
残留抵抗値 End resistance	1%又は、3Ωの大なる方以下 1% or 3Ω, whichever is greater
抵抗変化特性 Resistance taper	B (直線形) (Linear)
接触抵抗変化 Contact resistance variation	1%又は、1Ωの大なる方以下 1% or 1Ω, whichever is greater
定格電力 Power rating	0.75W/70℃
最高使用電圧 Max. input voltage	300V DC又は定格電力のいずれか小さい方 300V DC or power rating, whichever is smaller
抵抗温度係数 Temp. coefficient	±100ppm/℃ 200Ω～1MΩ ±250ppm/℃ その他の抵抗値 Other value.
絶縁抵抗 Insulation resistance	1,000MΩ以上 (500V DC) 1,000MΩ min. (500V DC)
耐電圧 Dielectric strength	900V AC 1分間 900V AC 1 minute

■機械的特性

MECHANICAL CHARACTERISTICS

機械的調整回転数 Mechanical turns	15±3 turns
回転トルク Shaft torque	29.4mN・m max. (300gf・cm max.)
ストップ強度 Stop strength	クラッチ機構 Clutch action.
使用温度範囲 Operating temp. range	-55℃～+125℃
重量 Weight	1.1g (P, X) 1.7g (PK2)

■環境特性

ENVIRONMENTAL CHARACTERISTICS

試験項目 Test item	試験条件 Test condition	規格 Standard
はんだ耐熱性 Soldering heat	350℃ 3 sec	△R/R ≤ ±1%
回転寿命 Rotation life	200サイクル (200 cycles)	△R/R ≤ ±3%
負荷寿命 Load life	70℃ 0.75W 1,000 hours	△R/R ≤ ±3% S.S. ≤ ±3%
熱衝撃 Thermal shock	-55℃, +125℃ (30 minutes) 5 cycles	△R/R ≤ ±2% S.S. ≤ ±1%
高周波振動 Vibration	10～2 kHz 振幅(amplitude) 1.5mm(10G) 12 hours	△R/R ≤ ±1% S.S. ≤ ±1%
衝撃 Shock	50G 6 msec. 6 directions for 3 time each	△R/R ≤ ±1% S.S. ≤ ±1%
低温動作 Low temperature exposure	-55℃, 0.75W 45 minutes	△R/R ≤ ±3% S.S. ≤ ±1%
高温露出 High temperature exposure	+125℃, 250 hours	△R/R ≤ ±3% S.S. ≤ ±1%
耐湿負荷寿命 Moisture and load life	+40℃, 90～95%RH, 0.75W 500 hours	△R/R ≤ ±3% S.S. ≤ ±1%
耐湿性 Moisture resistance	-10℃～+65℃ (90～95%RH) 10 cycles 240 hours	△R/R ≤ ±3%
温水浸漬 Seal test	+85℃ hot water 1 minute	3 bubbles max.
耐溶剤性 Solvent	アルコール等 Alcohol etc.	洗浄可能 Possible for washing

△R/R：全抵抗値変化 Change in total resistance

外形寸法図

(Unit : mm)

OUTLINE DIMENSIONS

- RJC094P
- RJC097P

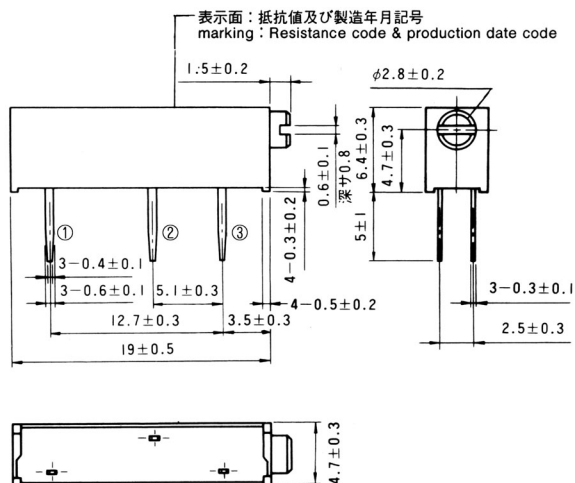

- RJC094X
- RJC097X

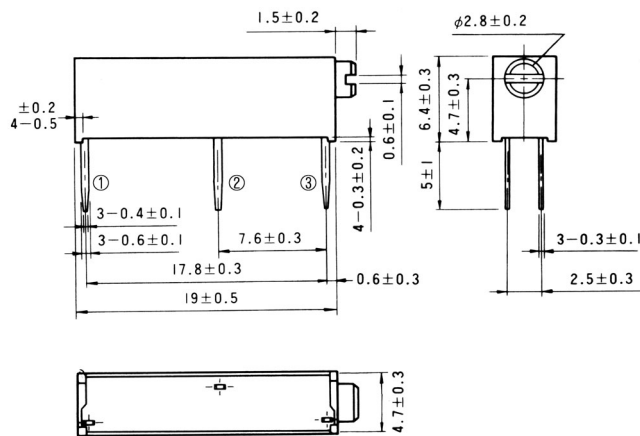

- RJC094PK
- RJC097PK

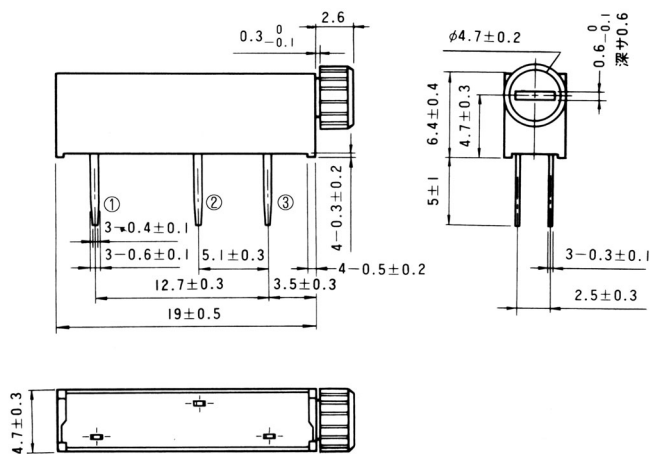

- RJC094PK2
- RJC097PK2

