

Device Modeling Report

COMPONENTS:
DIODE/ SCHOOTTKY RECTIFIER / STANDARD
PART NUMBER: 11EQS03L
MANUFACTURER: NIEC



Bee Technologies Inc.

PSpice model parameter	Model description
IS	Saturation Current
N	Emission Coefficient
RS	Series Resistance
IKF	High-injection Knee Current
CJO	Zero-bias Junction Capacitance
M	Junction Grading Coefficient
VJ	Junction Potential
ISR	Recombination Current Saturation Value
BV	Reverse Breakdown Voltage(a positive value)
IBV	Reverse Breakdown Current(a positive value)
TT	Transit Time
EG	Energy-band Gap

Forward Current Characteristic

Circuit Simulation Result

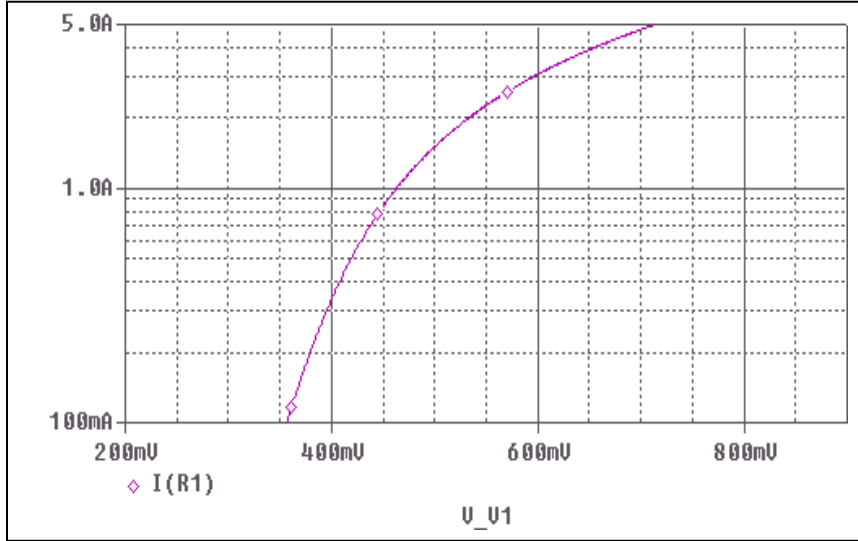

Evaluation Circuit

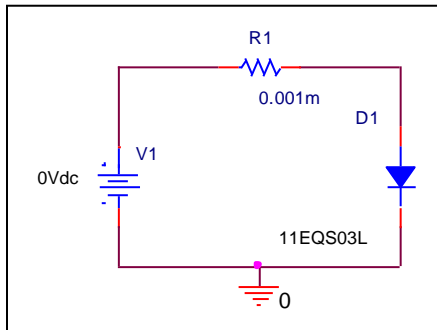

Comparison Graph

Circuit Simulation Result

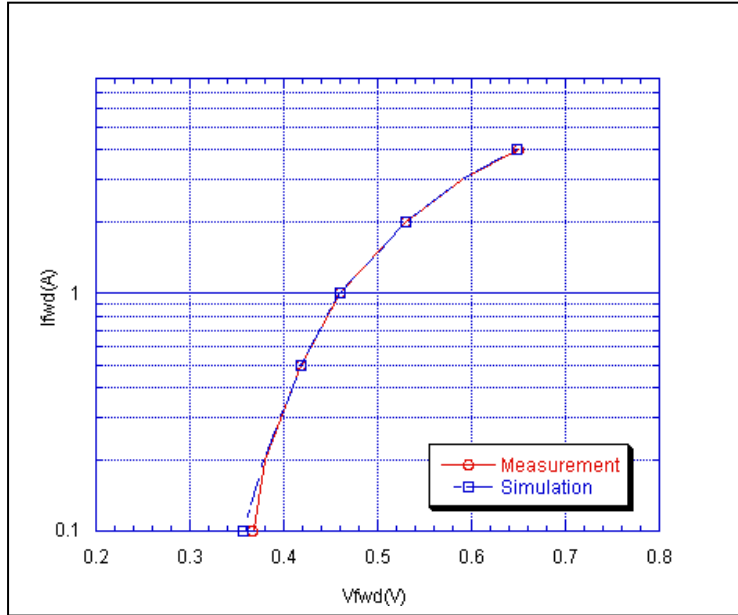

Simulation Result

I_{fwd} (A)	V_{fwd} (V) Measurement	V_{fwd} (V) Simulation	%Error
0.1	0.367	0.357	-2.72
0.2	0.380	0.379	-0.26
0.5	0.418	0.415	-0.72
1	0.460	0.456	-0.98
2	0.530	0.528	-0.42
3	0.590	0.586	-0.75
4	0.650	0.648	-0.31

Junction Capacitance Characteristic

Circuit Simulation Result

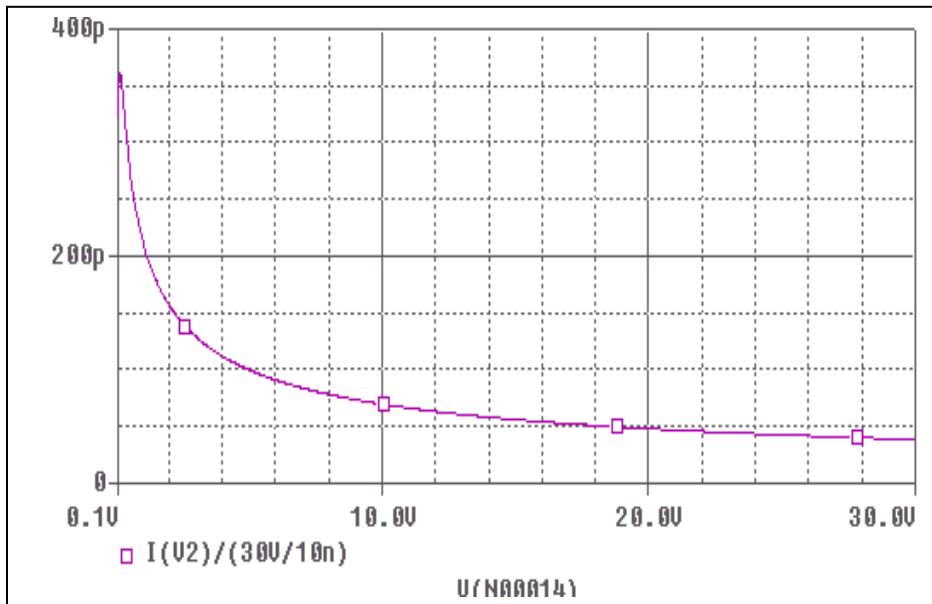

Evaluation Circuit

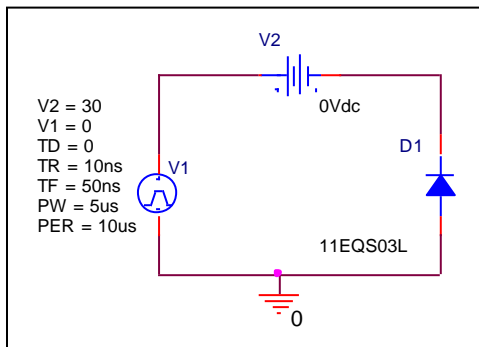

Comparison Graph

Circuit Simulation Result

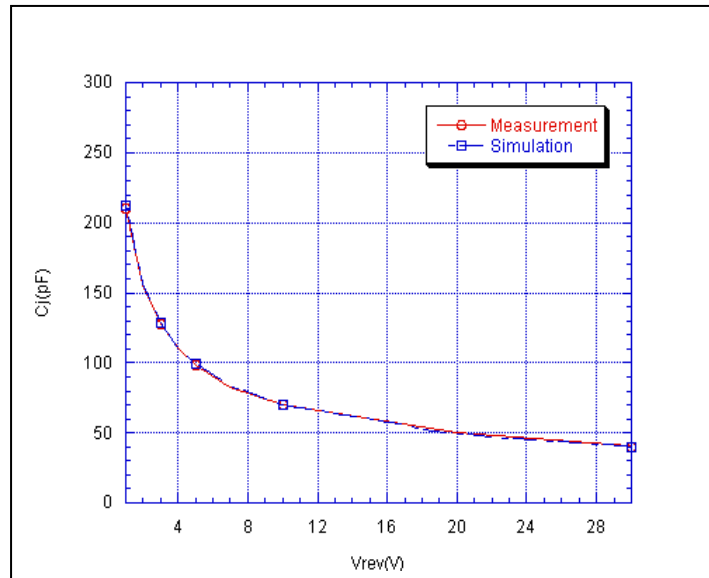

Simulation Result

Vrev(V)	Cj(pF) Measurement	Cj(pF) Simulation	%Error
1	210.000	212.150	1.02
2	156.000	157.000	0.64
3	128.000	128.210	0.16
4	111.000	109.540	-1.32
5	98.000	99.000	1.02
7	83.000	83.200	0.24
10	70.000	69.800	-0.29
20	50.000	49.200	-1.60