

Device Modeling Report

COMPONENTS: ZNR Transient/Surge Absorber
PART NUMBER: ERZV20D201
MANUFACTURER: Panasonic



Bee Technologies Inc.

ZNR Transient /Surge Absorber

Evaluation Circuit Result

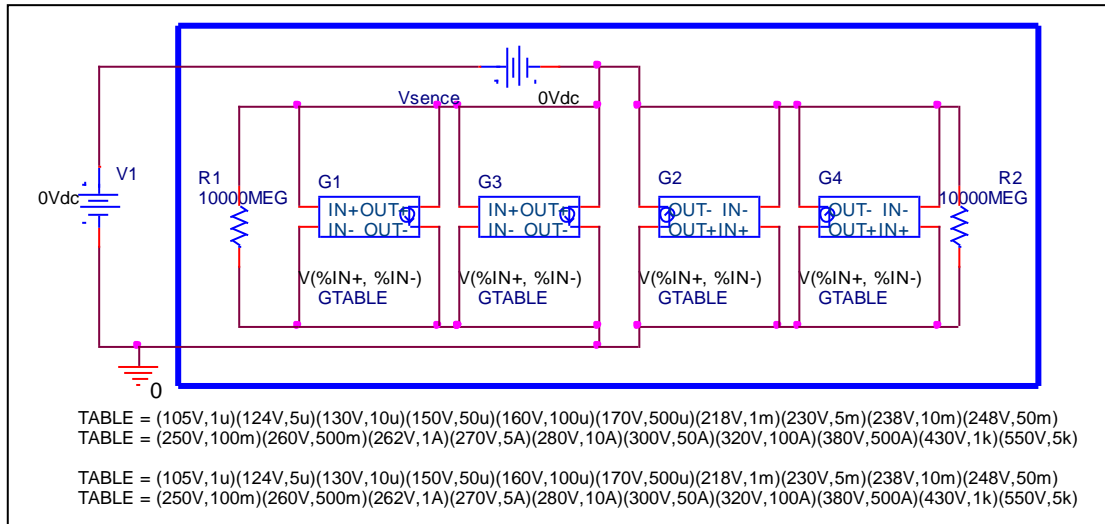

Circuit Simulation Result

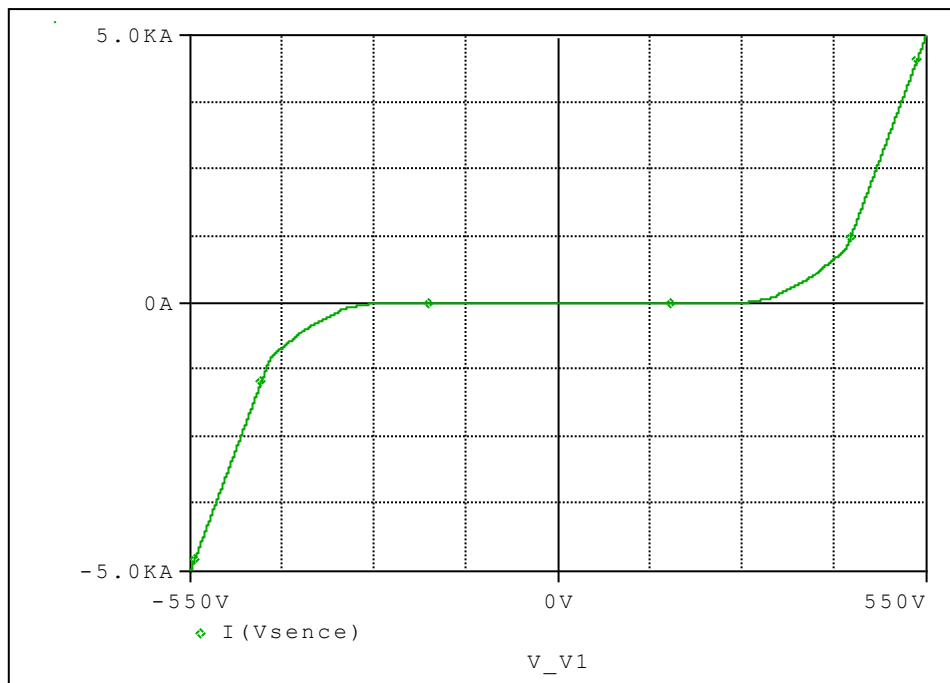

ZNR Transient /Surge Absorber

Simulation Result

I(A)	Vfwd (V)		%Error
	Measurement	Simulation	
1.00E-06	105	109.64	4.419
5.00E-06	124	125.16	0.935
1.00E-05	130	130.48	0.369
5.00E-05	150	150.19	0.127
1.00E-04	160	160.02	0.013
5.00E-04	170	170.09	0.053
1.00E-03	218	218	0.000
5.00E-03	230	230	0.000
1.00E-02	238	238	0.000
5.00E-02	248	248	0.000
1.00E-01	250	235	6.000
5.00E-01	260	251.25	3.365
1.00E+00	262	260.1	0.725
5.00E+00	270	270.1	0.037
1.00E+01	280	280.02	0.007
5.00E+01	300	300.02	0.007
1.00E+02	320	320	0.000
5.00E+02	380	380	0.000
1.00E+03	430	430	0.000
5.00E+03	550	550	0.000

Comparison Graph

Circuit Simulation Result

