

# Device Modeling Report

COMPONENTS: DC MOTOR  
PART NUMBER: RS-380PH  
MANUFACTURER: MABUCHI MOTOR



**Bee Technologies Inc.**

## Theory: Auto Balancing Bridge Method

### Optimization of Simulation

Range of adjustment Frequency:40 to10K(Hz)

Frequency vs.  $|Z|$  and Frequency vs.  $\theta z$  Characteristic

Attention)

*Please use SPICE MODEL within the range from 40 to 10K(Hz) for best accuracy.*

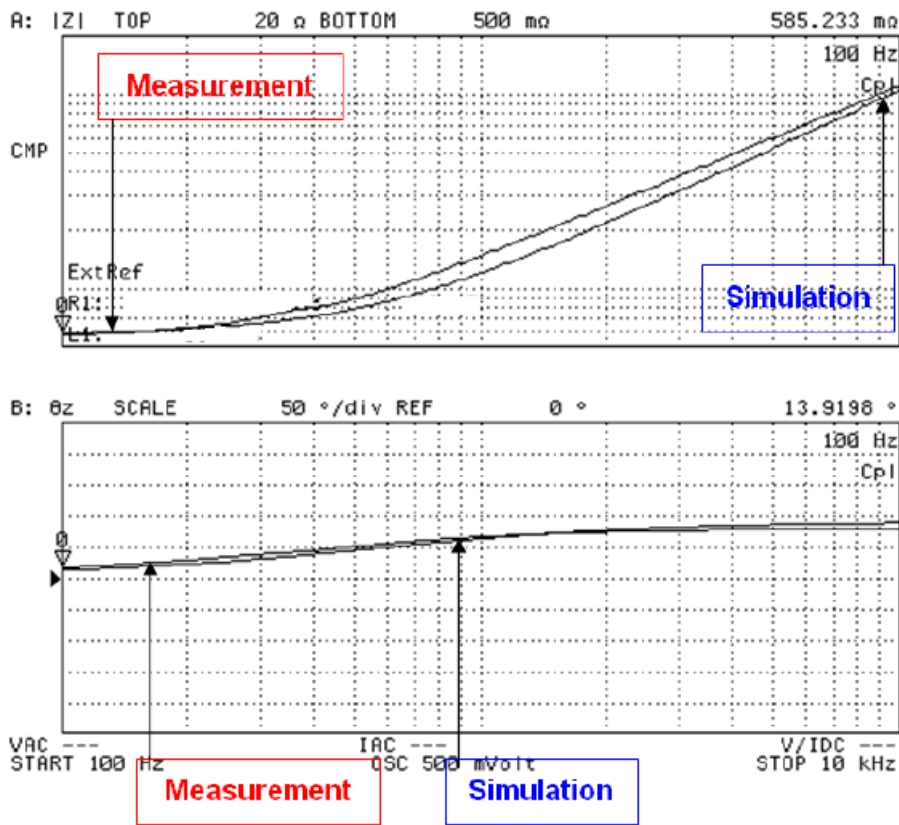

LM	
RS	
CP	

# DC Motor Voltage and Current Characteristics at No load

## Circuit simulation result

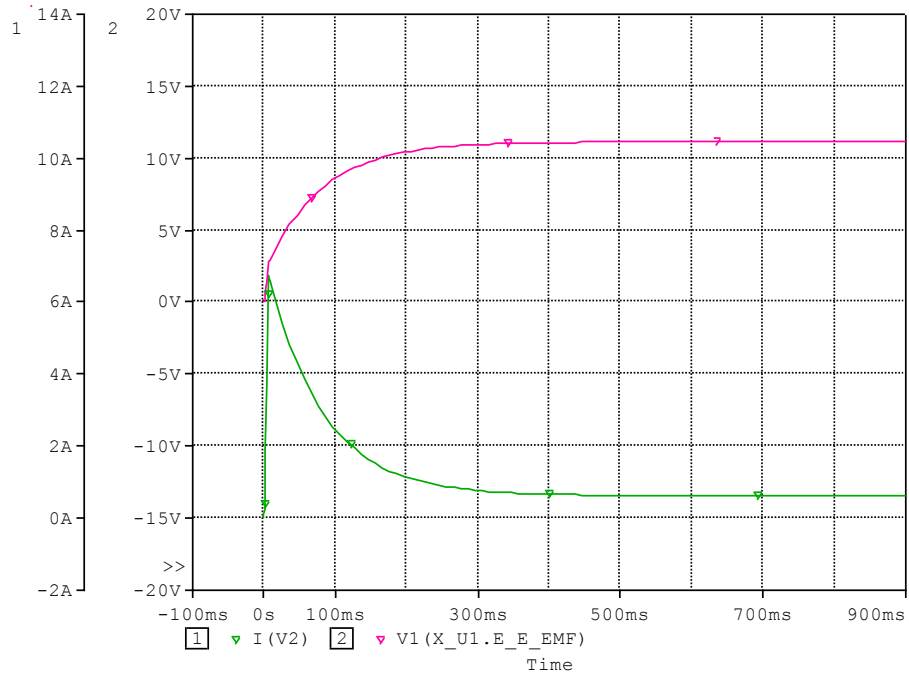

## Evaluation circuit

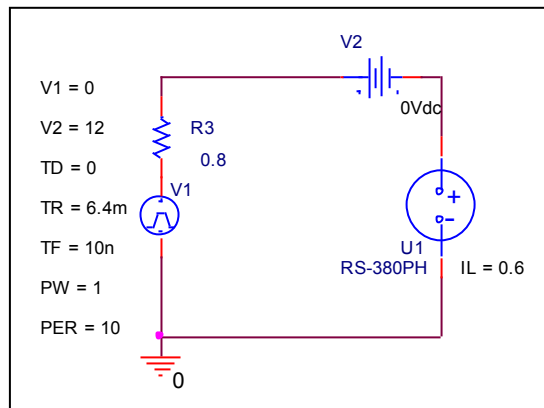

# DC Motor Voltage and Current Characteristics (No load) Reference

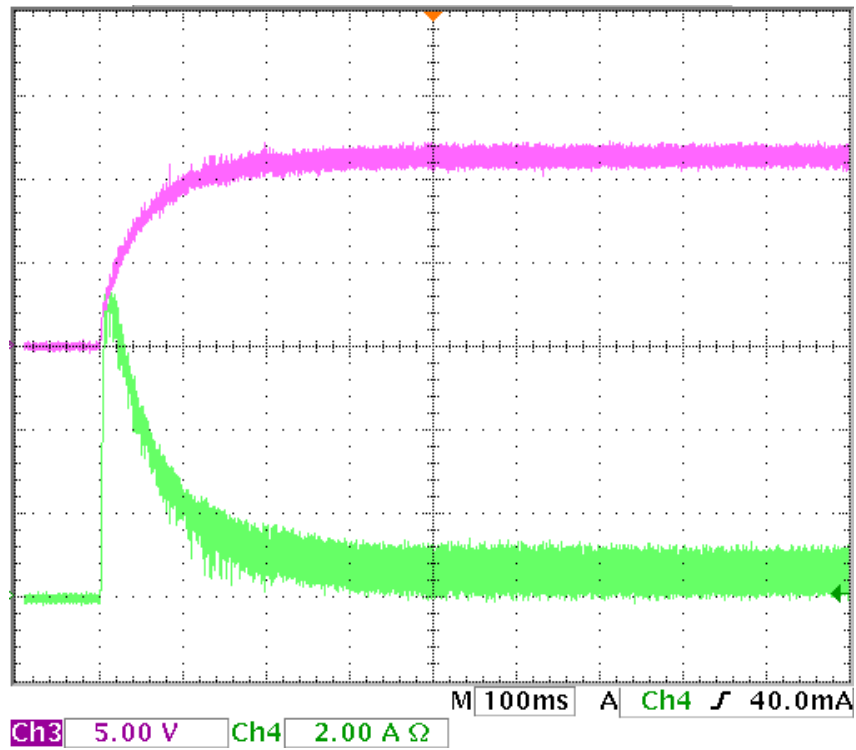

# DC Motor Voltage and Current Characteristics at Fan load

## Circuit simulation result

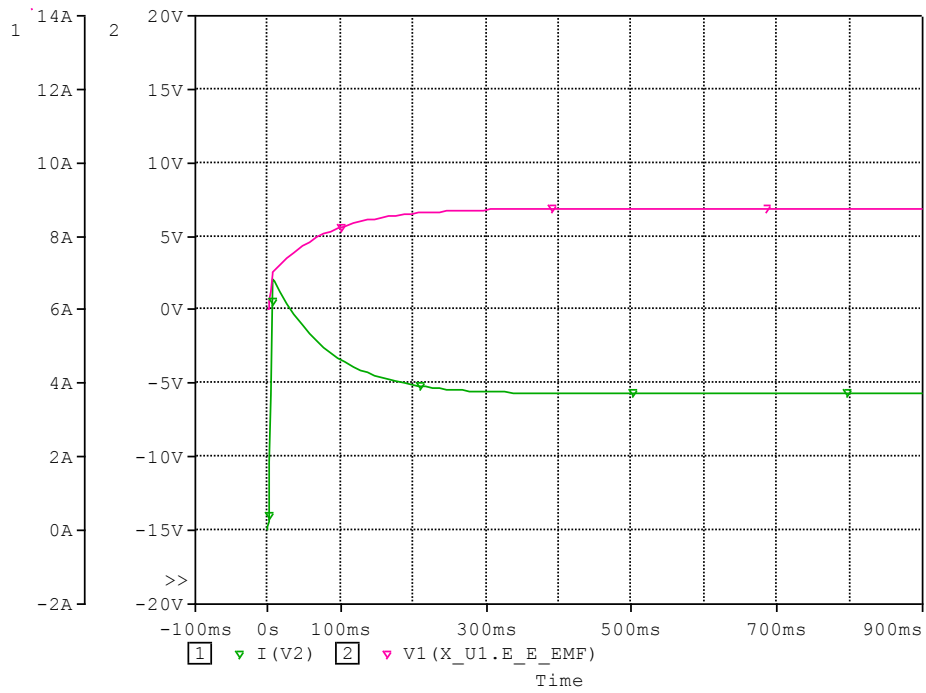

## Evaluation circuit

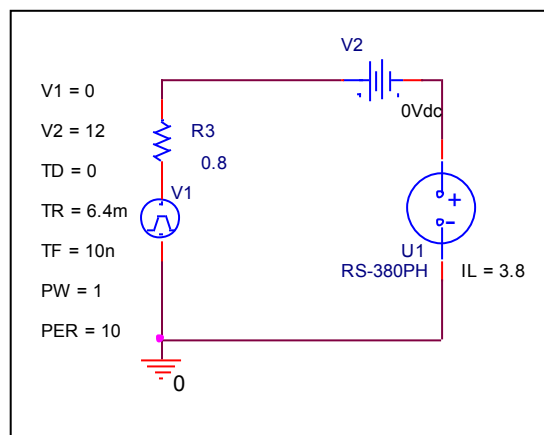

## DC Motor Voltage and Current Characteristics (Fan load) Reference

