

Device Modeling Report

COMPONENTS: DARLINGTON TRANSISTOR
PART NUMBER: 2SD560
MANUFACTURER: NEC CORPORATION



Bee Technologies Inc.

BIPOLAR JUNCTION TRANSISTOR MODEL

PSpice model parameter	Model description
IS	Saturation Current
BF	Ideal Maximum Forward Beta
NF	Forward Current Emission Coefficient
VAF	Forward Early Voltage
IKF	Forward Beta Roll-off Knee Current
ISE	Non-ideal Base-Emitter Diode Saturation Current
NE	Non-ideal Base-Emitter Diode Emission Coefficient
BR	Ideal Maximum Reverse Beta
NR	Reverse Emission Coefficient
VAR	Reverse Early Voltage
IKR	Reverse Beta Roll-off Knee Current
RE	Emitter Resistance
RB	Base Resistance
RC	Series Collector Resistance
CJE	Zero-bias Emitter-Base Junction Capacitance
VJE	Emitter-Base Junction Potential
MJE	Emitter-Base Junction Grading Coefficient
CJC	Zero-bias Collector-Base Junction Capacitance
VJC	Collector-base Junction Potential
MJC	Collector-base Junction Grading Coefficient
TF	Forward Transit Time
TR	Reverse Transit Time
XTB	Forward Beta Temperature Coefficient

DIODE MODEL

PSpice model parameter	Model description
IS	Saturation Current
RS	Series Resistance
CJO	Zero-bias Junction Capacitance
BV	Reverse Breakdown Voltage(a positive value)
IBV	Reverse Breakdown Current(a positive value)
TT	Transit Time

Ic-hFE Characteristics

Simulation result

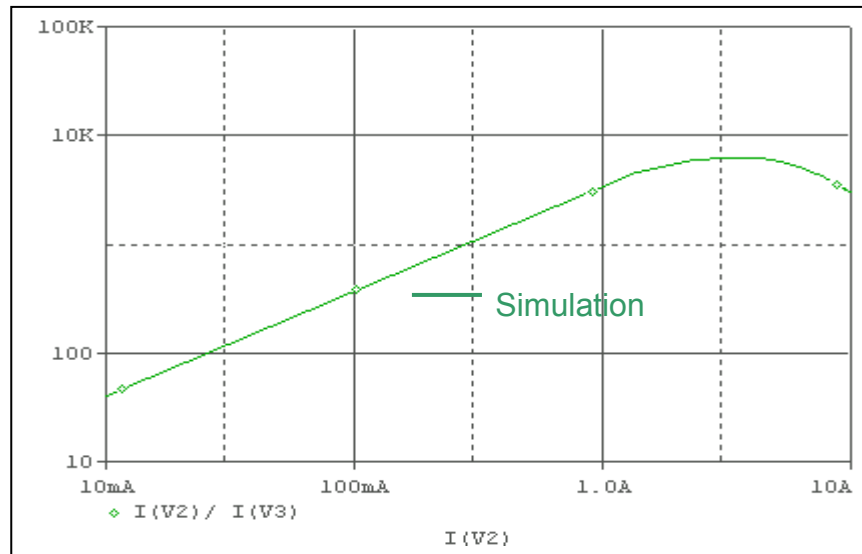

Evaluation Circuit

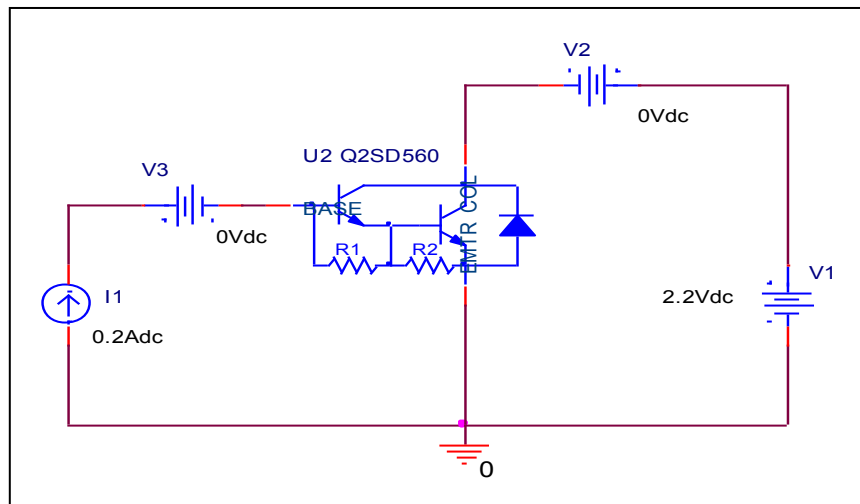

Peak of hFE	Measurement	Simulation	% Error
IC(A)	3.5	3.53	0.857
hFE(k)	6.2	6.25	0.806

Vce(sat) Voltage & Vbe(sat) Voltage Characteristics

Simulation result

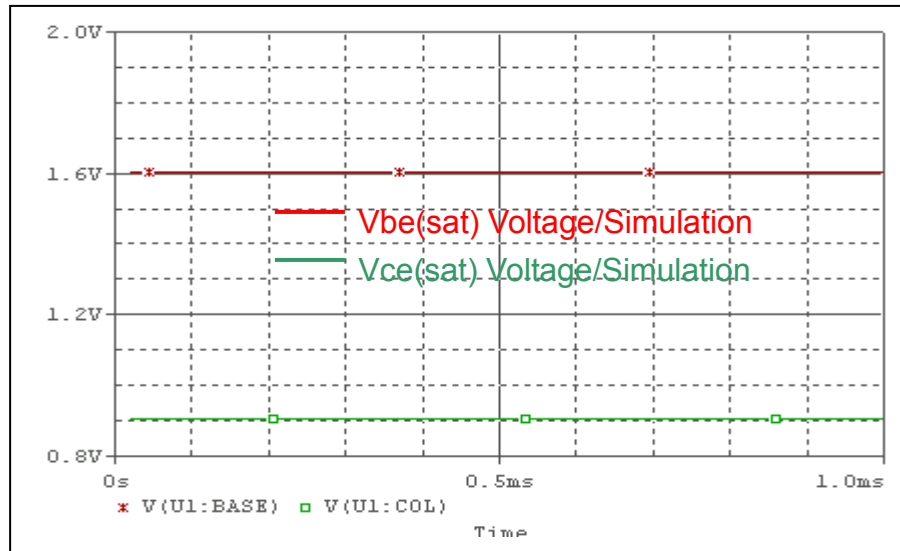

Evaluation Circuit

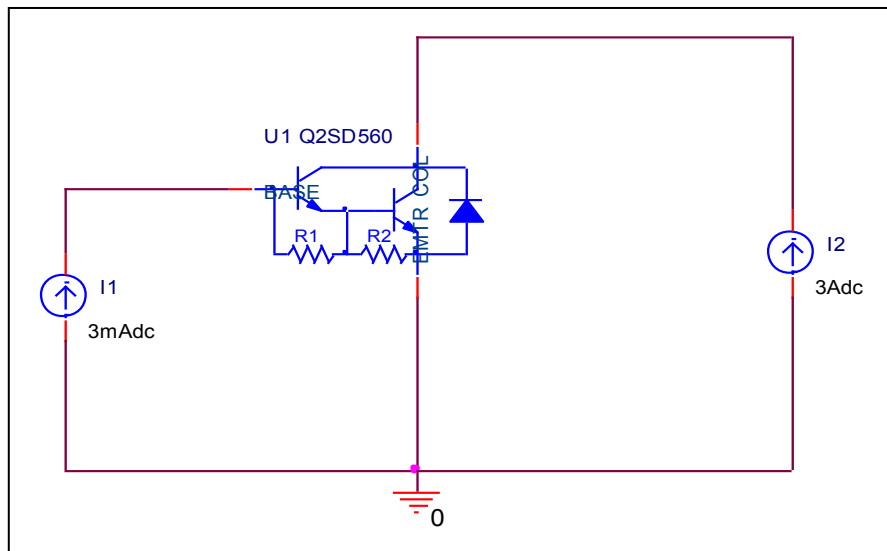

	Measurement	Simulation	% Error
Vce(sat)	0.9	0.903	0.333
Vbe(sat)	1.6	1.602	0.125

Output Characteristics

Simulation result

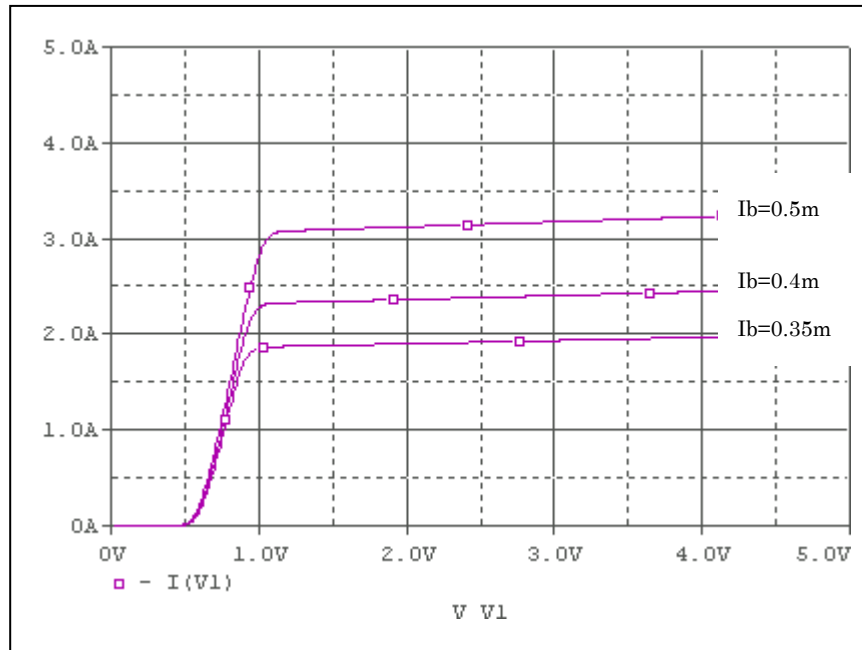

Evaluation Circuit

