

Device Modeling Report

COMPONENTS: Ultra Violet Laser Diode
PART NUMBER: NDHU110APAE2
MANUFACTURER: NICHIA CORPORATION



Bee Technologies Inc.

PSpice model parameter	Model description
IS	Saturation Current
N	Emission Coefficient
RS	Series Resistance
IKF	High-injection Knee Current
CJO	Zero-bias Junction Capacitance
M	Junction Grading Coefficient
VJ	Junction Potential
ISR	Recombination Current Saturation Value
BV	Reverse Breakdown Voltage(a positive value)
IBV	Reverse Breakdown Current(a positive value)
TT	Transit Time

Optical Output Power vs. Forward current characteristics

Circuit simulation result

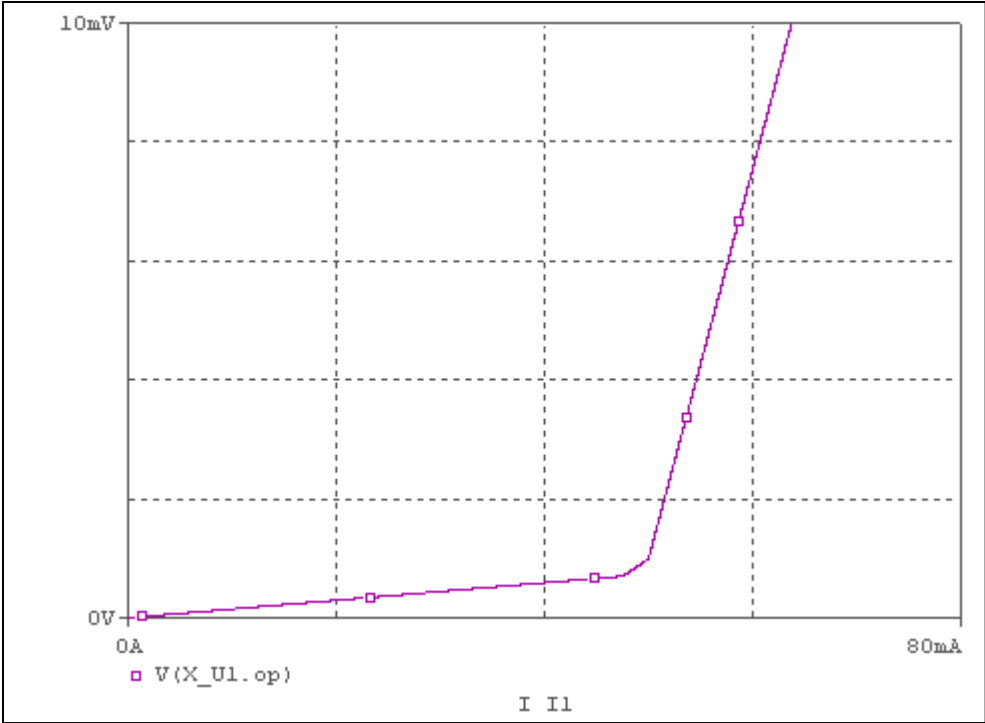

Evaluation circuit

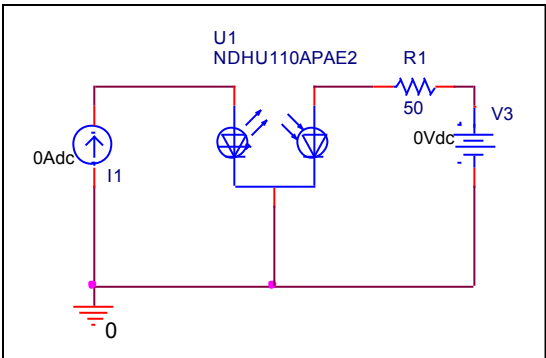

Comparison graph

Circuit simulation result

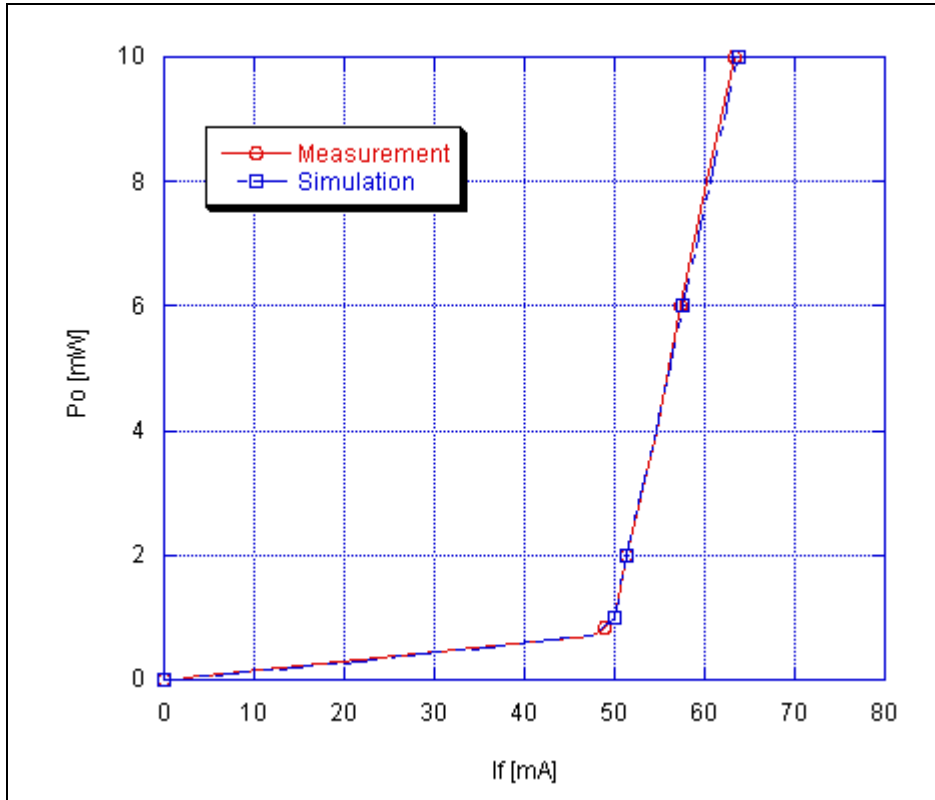

Simulation Result

Po[mW]	IF[mA]		Error (%)
	Measurement	Simulation	
0.7	47.5	47.5	0
1	50	50	0
2	51.33	51.27	0.116891
4	54.66	54.583	0.140871
6	57.33	57.638	0.537241
8	60.33	60.694	0.603348
10	63.33	63.749	0.661614

Forward Voltage vs. Forward Current characteristics

Circuit simulation result

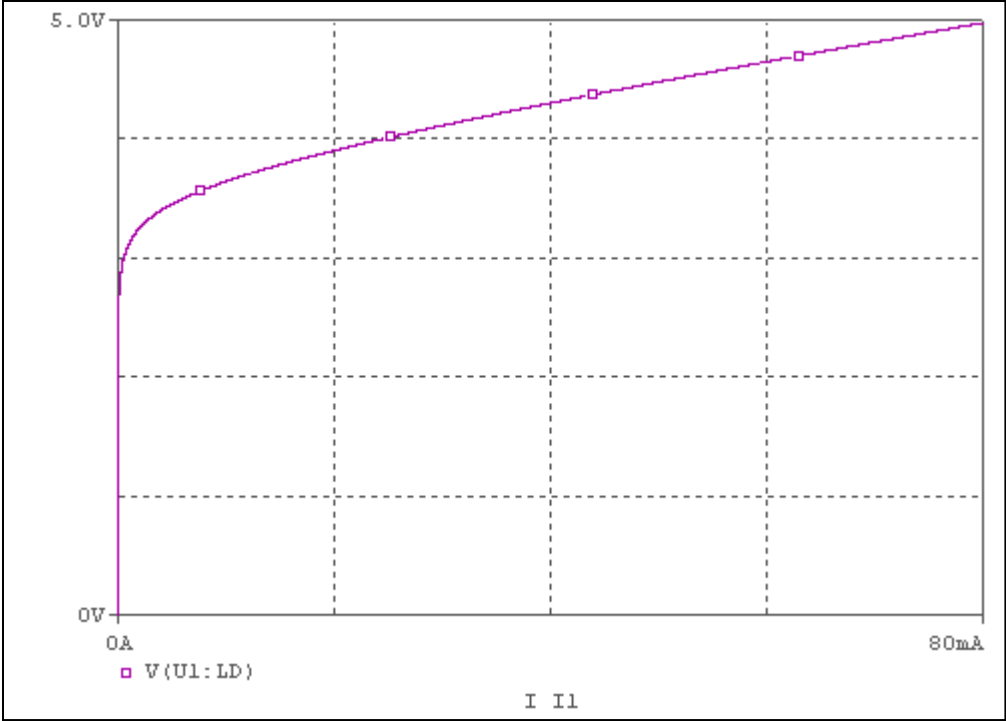

Evaluation circuit

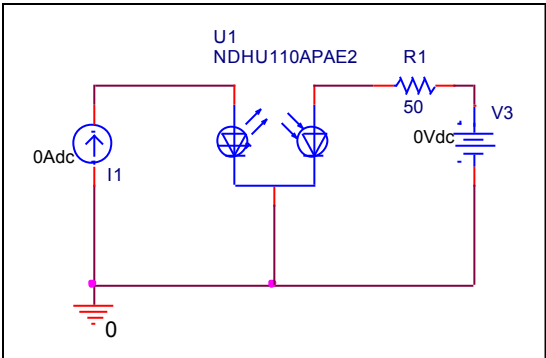

Comparison graph

Circuit simulation result

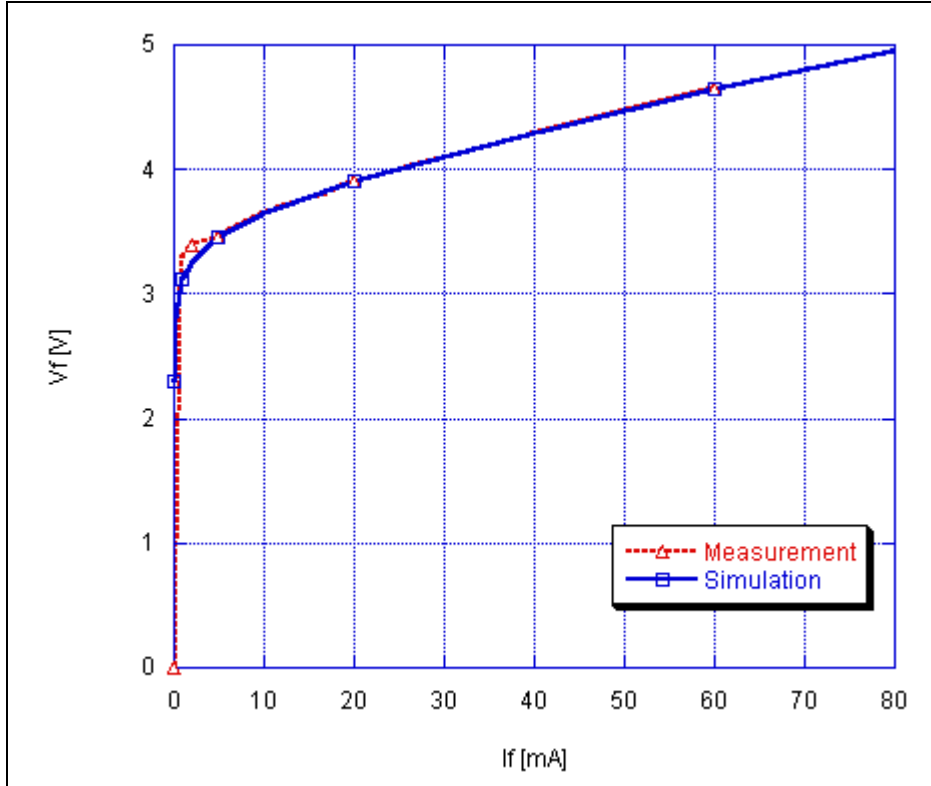

Simulation Result

If [mA]	Vf [V]		Error (%)
	Measurement	Simulation	
5	3.45	3.453	0.086957
10	3.65	3.6431	0.189041
20	3.9	3.9033	0.084615
40	4.3	4.2929	0.165116
60	4.65	4.6489	0.023656

Monitor Current vs. Optical Output Power characteristics

Circuit simulation result

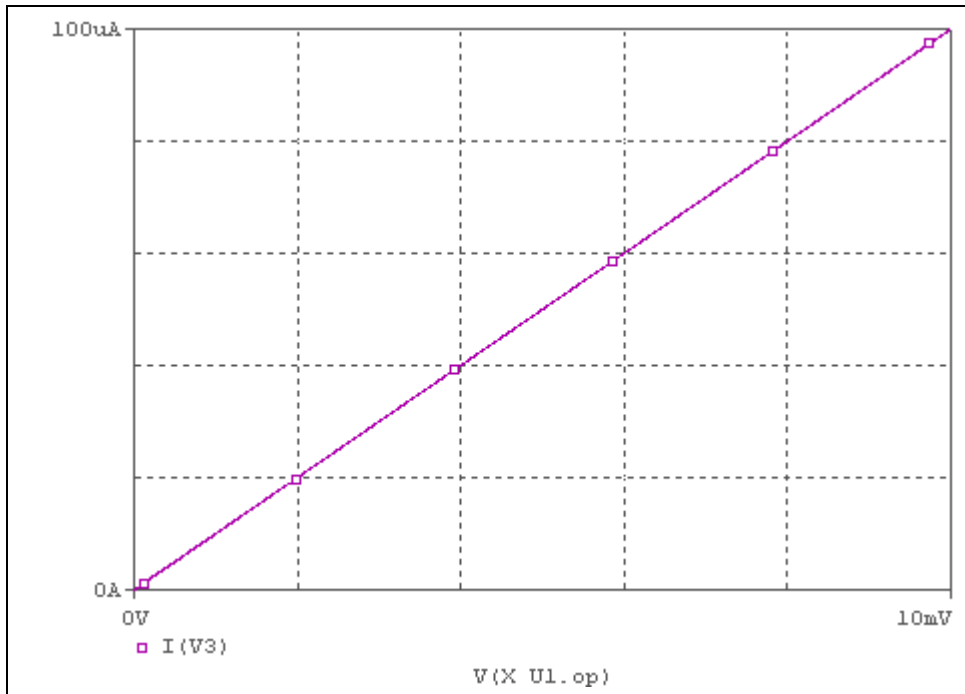

Evaluation circuit

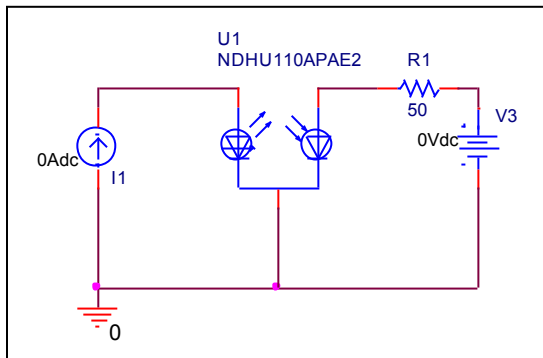

Simulation Result

Po[mW]	I _{mon} [mA]		Error (%)
	Measurement	Simulation	
10	0.1 [Type]	0.1	0