

TXS0108E 8ビット双方向レベルシフト電圧トランスレータ オープン・ドレイン/プッシュプル・アプリケーション向け

1 特長

- 方向制御信号不要
- 最大データレート
 - 110Mbps (プッシュプル)
 - 1.2Mbps (オープン・ドレイン)
- 1.2V~3.6V (Aポート)、1.65V~5.5V (Bポート)
($V_{CCA} \leq V_{CCB}$)
- 電源投入のシーケンス不要— V_{CCA} と V_{CCB} のいずれからでも立ち上げ可能
- JESD 78, Class II準拠で100mA超のラッチアップ性能
- JESD 22を超えるESD保護(Aポート)
 - 2000V、人体モデル(A114-B)
 - 150V、マシン・モデル(A115-A)
 - 1000V、デバイス帯電モデル(C101)
- IEC 61000-4-2 ESD (Bポート)
 - 接触放電: $\pm 8kV$
 - 空中放電: $\pm 6kV$

2 アプリケーション

- 携帯電話
- スマートフォン
- タブレット
- デスクトップPC

3 概要

この8ビット非反転トランスレータは、設定可能な2つの独立した電源レールを採用しています。Aポートは V_{CCA} ピンの電源電圧に追従し、 V_{CCA} ピンには1.2V~3.6Vの電源電圧を供給できます。Bポートは V_{CCB} ピンの電源電圧に追従し、 V_{CCB} ピンには1.65V~5.5Vの電源電圧を供給できます。2つの入力電源ピンにより、1.2V、1.8V、2.5V、3.3V、5Vの任意の電圧ノード間で低電圧の双方向変換が可能になります。

出力イネーブル(OE)入力がLowのとき、全出力がハイ・インピーダンス(Hi-Z)状態になります。

電源投入時または切断時のHi-Z状態を確保するには、OEをプルダウン抵抗でGNDにつなぐ必要があります。この抵抗の最小値は、ドライバの電流ソース能力によって決まります。

製品情報(1)

型番	パッケージ	本体サイズ(公称)
TXS0108EPW	TSSOP (20)	6.50mm×6.40mm
TXS0108ERGY	VQFN (20)	4.50mm×3.50mm
TXS0108EZXY	UFBGA (20)	3.00mm×2.50mm

(1) 利用可能なすべてのパッケージについては、このデータシートの末尾にある注文情報を参照してください。

アプリケーション概略図

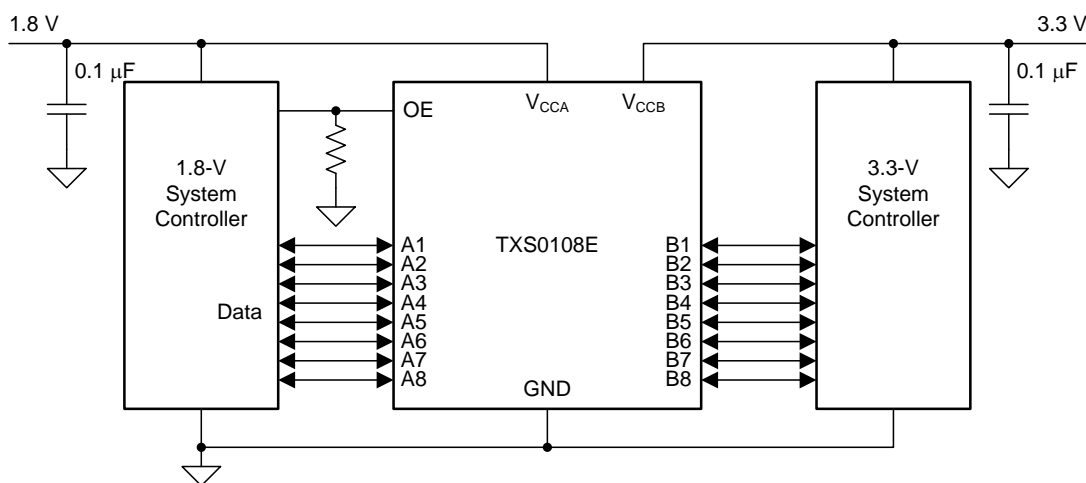

目次

1	特長	1			
2	アプリケーション	1			
3	概要	1			
4	改訂履歴	2			
5	Pin Configuration and Functions	3			
6	Specifications	5			
6.1	Absolute Maximum Ratings	5			
6.2	ESD Ratings	5			
6.3	Recommended Operating Conditions	6			
6.4	Thermal Information	6			
6.5	Electrical Characteristics: $T_A = -40^{\circ}\text{C}$ to 85°C	7			
6.6	Timing Requirements: $V_{CCA} = 1.2\text{ V}$	8			
6.7	Timing Requirements: $V_{CCA} = 1.5\text{ V} \pm 0.1\text{ V}$	8			
6.8	Timing Requirements: $V_{CCA} = 1.8\text{ V} \pm 0.15\text{ V}$	8			
6.9	Timing Requirements: $V_{CCA} = 2.5\text{ V} \pm 0.2\text{ V}$	8			
6.10	Timing Requirements: $V_{CCA} = 3.3\text{ V} \pm 0.3\text{ V}$	8			
6.11	Switching Characteristics: $V_{CCA} = 1.2\text{ V}$	9			
6.12	Switching Characteristics: $V_{CCA} = 1.5\text{ V} \pm 0.1\text{ V}$	10			
6.13	Switching Characteristics: $V_{CCA} = 1.8\text{ V} \pm 0.15\text{ V}$	11			
6.14	Switching Characteristics: $V_{CCA} = 2.5\text{ V} \pm 0.2\text{ V}$	12			
6.15	Switching Characteristics: $V_{CCA} = 3.3\text{ V} \pm 0.3\text{ V}$	13			
6.16	Operating Characteristics: $V_{CCA} = 1.2\text{ V}$ to 1.5 V , $V_{CCB} = 1.2\text{ V}$ to 1.5 V	14			
6.17	Operating Characteristics: $V_{CCA} = 1.8\text{ V}$ to 3.3 V , $V_{CCB} = 1.8\text{ V}$ to 3.3 V	14			
7	Typical Characteristics	15			
8	Parameter Measurement Information	16			
8.1	Load Circuits	16			
8.2	Voltage Waveforms	17			
9	Detailed Description	18			
9.1	Overview	18			
9.2	Functional Block Diagram	18			
9.3	Feature Description	19			
9.4	Device Functional Modes	20			
10	Application and Implementation	21			
10.1	Application Information	21			
10.2	Typical Application	21			
11	Power Supply Recommendations	23			
12	Layout	23			
12.1	Layout Guidelines	23			
12.2	Layout Example	23			
13	デバイスおよびドキュメントのサポート	24			
13.1	コミュニティ・リソース	24			
13.2	商標	24			
13.3	静電気放電に関する注意事項	24			
13.4	Glossary	24			
14	メカニカル、パッケージ、および注文情報	24			

4 改訂履歴

Revision E (February 2018) から Revision F に変更		Page
•	Changed T_A from 125°C to 85°C in the <i>Recommended Operating Conditions</i> table.....	6
Revision D (February 2016) から Revision E に変更		Page
•	Added junction temperature	5
Revision C (December 2014) から Revision D に変更		Page
•	「ESD定格」を変更	1
Revision B (November 2013) から Revision C に変更		Page
•	「ピン構成および機能」セクション、「ESD定格」の表、「機能説明」セクション、「デバイスの機能モード」、「アプリケーションと実装」セクション、「電源に関する推奨事項」セクション、「レイアウト」セクション、「デバイスおよびドキュメントのサポート」セクション、「メカニカル、パッケージ、および注文情報」セクション 追加	1

5 Pin Configuration and Functions

**ZXY PACKAGE
20 BUMP
(BOTTOM VIEW)**

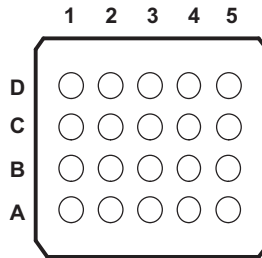

**RGY PACKAGE
20 PINS
(TOP VIEW)**

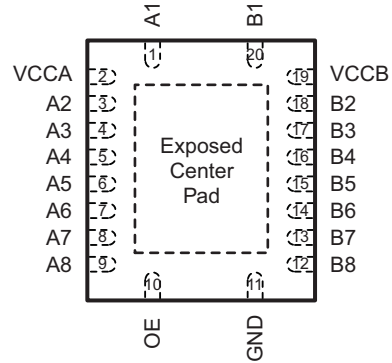

**PW PACKAGE
20-PIN TSSOP
(TOP VIEW)**

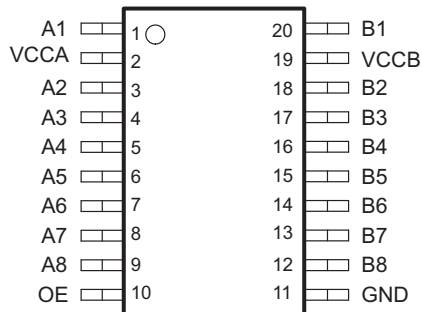

The exposed center pad, if used, must be connected as a secondary ground or left electrically open.

Table 1. Pin Assignments

	1	2	3	4	5
D	VCCB	B2	B4	B6	B8
C	B1	B3	B5	B7	GND
B	A1	A3	A5	A7	OE
A	VCCA	A2	A4	A6	A8

Pin Functions

PIN NO.			TYPE ⁽¹⁾	DESCRIPTION
NAME	PW, RGY	ZXY		
A1	1	B1	I/O	Input/output 1. Referenced to V_{CCA}
A2	3	A2	I/O	Input/output 2. Referenced to V_{CCA}
A3	4	B2	I/O	Input/output 3. Referenced to V_{CCA}
A4	5	A3	I/O	Input/output 4. Referenced to V_{CCA}
A5	6	B3	I/O	Input/output 5. Referenced to V_{CCA}
A6	7	A4	I/O	Input/output 6. Referenced to V_{CCA}
A7	8	B4	I/O	Input/output 7. Referenced to V_{CCA}
A8	9	A5	I/O	Input/output 8. Referenced to V_{CCA}
B1	20	C 1	I/O	Input/output 1. Referenced to V_{CCB}
B2	18	D2	I/O	Input/output 2. Referenced to V_{CCB}
B3	17	C2	I/O	Input/output 3. Referenced to V_{CCB}
B4	16	D3	I/O	Input/output 4. Referenced to V_{CCB}
B5	15	C3	I/O	Input/output 5. Referenced to V_{CCB}
B6	14	D4	I/O	Input/output 6. Referenced to V_{CCB}
B7	13	C4	I/O	Input/output 7. Referenced to V_{CCB}
B8	12	D5	I/O	Input/output 8. Referenced to V_{CCB}
GND	11	C5	—	Ground
OE	10	B5	I	Tri-state output-mode enable. Pull OE low to place all outputs in 3-state mode. Referenced to V_{CCA} .
VCCA	2	A1	P	A-port supply voltage. $1.2\text{ V} \leq V_{CCA} \leq 3.6\text{ V}$, $V_{CCA} \leq V_{CCB}$.
VCCB	19	D1	P	B-port supply voltage. $1.65\text{ V} \leq V_{CCB} \leq 5.5\text{ V}$.
Thermal Pad			—	For the RGY package, the exposed center thermal pad must be either be connected to Ground or left electrically opened.

(1) I = input, O = output, I/O = input and output, P = power

6 Specifications

6.1 Absolute Maximum Ratings⁽¹⁾

over operating free-air temperature range (unless otherwise noted)

		MIN	MAX	UNIT
Supply voltage, V_{CCA}		-0.5	4.6	V
Supply voltage, V_{CCB}		-0.5	5.5	V
Input voltage, V_I ⁽²⁾	A port	-0.5	4.6	V
	B port	-0.5	6.5	
Voltage applied to any output in the high-impedance or power-off state, V_O ⁽²⁾	A port	-0.5	4.6	V
	B port	-0.5	6.5	
Voltage applied to any output in the high or low state, V_O ^{(2) (3)}	A port	-0.5	$V_{CCA} + 0.5$	V
	B port	-0.5	$V_{CCB} + 0.5$	V
Input clamp current, I_{IK}	$V_I < 0$		-50	mA
Output clamp current, I_{OK}	$V_O < 0$		-50	mA
Continuous output current, I_O		-50	50	mA
Continuous current through V_{CCA} , V_{CCB} , or GND		-100	100	mA
Junction temperature, T_J			150	°C
Storage temperature, T_{stg}		-65	150	°C

- (1) Stresses beyond those listed under *Absolute Maximum Ratings* may cause permanent damage to the device. These are stress ratings only, and functional operation of the device at these or any other conditions beyond those indicated under *Recommended Operating Conditions* is not implied. Exposure to absolute-maximum-rated conditions for extended periods may affect device reliability.
- (2) The input and output negative Voltage ratings may be exceeded if the input and output current ratings are observed.
- (3) The value of V_{CCA} and V_{CCB} are provided in the recommended operating conditions table.

6.2 ESD Ratings

		VALUE	UNIT
$V_{(ESD)}$	Electrostatic discharge	Human body model (HBM), per ANSI/ESDA/JEDEC JS-001 ⁽¹⁾	±2000
		Charged-device model (CDM), per JEDEC specification JESD22-C101 ⁽²⁾	±1000
		Machine model (MM)	±150
		IEC 61000-4-2 ESD (B Port) Contact Discharge	±8000
		IEC 61000-4-2 ESD (B Port) Air-Gap Discharge	±6000

- (1) JEDEC document JEP155 states that 500 V HBM allows safe manufacturing with a standard ESD control process.
- (2) JEDEC document JEP157 states that 250 V CDM allows safe manufacturing with a standard ESD control process.

6.3 Recommended Operating Conditions

 over operating free-air temperature range (unless otherwise noted)⁽¹⁾⁽²⁾

				MIN	MAX	UNIT	
V _{CCA}	Supply voltage ⁽³⁾			1.2	3.6	V	
V _{CCB}	Supply voltage ⁽³⁾			1.65	5.5	V	
V _{IH}	High-level input voltage	A-Port I/Os	V _{CCA} (V) = 1.2 to 1.95	V _{CCB} (V) = 1.65 to 5.5	V _{CCI} – 0.2	V _{CCI}	V
			V _{CCA} (V) = 1.95 to 3.6	V _{CCB} (V) = 1.65 to 5.5	V _{CCI} – 0.4	V _{CCI}	V
		B-Port I/Os	V _{CCA} (V) = 1.2 to 3.6	V _{CCB} (V) = 1.65 to 5.5	V _{CCI} – 0.4	V _{CCI}	V
		OE	V _{CCA} (V) = 1.2 to 3.6	V _{CCB} (V) = 1.65 to 5.5	V _{CCA} × 0.65	5.5	V
V _{IL}	Low-level input voltage	A-Port I/Os	V _{CCA} (V) = 1.2 to 1.95	V _{CCB} (V) = 1.65 to 5.5	0	0.15	V
			V _{CCA} (V) = 1.95 to 3.6	V _{CCB} (V) = 1.65 to 5.5	0	0.15	V
		B-Port I/Os	V _{CCA} (V) = 1.2 to 3.6	V _{CCB} (V) = 1.65 to 5.5	0	0.15	V
		OE	V _{CCA} (V) = 1.2 to 3.6	V _{CCB} (V) = 1.65 to 5.5	0	V _{CCA} × 0.35	V
Δt/Δv	Input transition rise or fall rate	A-Port I/Os Push-pull	V _{CCA} (V) = 1.2 to 3.6	V _{CCB} (V) = 1.65 to 5.5		10	ns/V
		B-Port I/Os Push-pull	V _{CCA} (V) = 1.2 to 3.6	V _{CCB} (V) = 1.65 to 5.5		10	ns/V
		Control input	V _{CCA} (V) = 1.2 to 3.6	V _{CCB} (V) = 1.65 to 5.5		10	ns/V
T _A	Operating free-air temperature			–40	85	°C	

 (1) V_{CCI} is the V_{CC} associated with the data input port.

 (2) V_{CCO} is the V_{CC} associated with the output port.

 (3) V_{CCA} must be less than or equal to V_{CCB}, and V_{CCA} must not exceed 3.6 V.

6.4 Thermal Information

THERMAL METRIC ⁽¹⁾		TXS0108E			UNIT
		PW (TSSOP)	RGY	ZXY	
		20 PINS	20 PINS	20 PINS	
R _{θJA}	Junction-to-ambient thermal resistance	101.5	34.7	101.5	°C/W
R _{θJC(top)}	Junction-to-case (top) thermal resistance	35.9	39.5	35.9	°C/W
R _{θJB}	Junction-to-board thermal resistance	52.4	12.7	52.4	°C/W
ψ _{JT}	Junction-to-top characterization parameter	2.3	0.9	2.3	°C/W
ψ _{JB}	Junction-to-board characterization parameter	51.9	12.7	51.9	°C/W
R _{θJC(bot)}	Junction-to-case (bottom) thermal resistance	—	7.5	—	°C/W

 (1) For more information about traditional and new thermal metrics, see the [IC Package Thermal Metrics application report](#).

6.5 Electrical Characteristics: $T_A = -40^{\circ}\text{C}$ to 85°C ⁽¹⁾⁽²⁾⁽³⁾

over recommended operating free-air temperature range (unless otherwise noted)

PARAMETER	TEST CONDITIONS	V_{CCA} (V)	V_{CCB} (V)	$T_A = 25^{\circ}\text{C}$			$T_A = -40^{\circ}\text{C}$ to 85°C		UNIT
				MIN	TYP	MAX	MIN	MAX	
V_{OHA}	Port A output high voltage $I_{OH} = -20\ \mu\text{A}$ $V_{IB} \geq V_{CCB} - 0.4\ \text{V}$	1.2	1.65 to 5.5	$V_{CCA} \times 0.67$					V
V_{OLA}	Port A output low voltage	$I_{OL} = 135\ \mu\text{A}, V_{IB} \leq 0.15\ \text{V}$	1.2	1.65 to 5.5				0.25	V
		$I_{OL} = 180\ \mu\text{A}, V_{IB} \leq 0.15\ \text{V}$	1.4	1.65 to 5.5				0.4	
		$I_{OL} = 220\ \mu\text{A}, V_{IB} \leq 0.15\ \text{V}$	1.65	1.65 to 5.5				0.4	
		$I_{OL} = 300\ \mu\text{A}, V_{IB} \leq 0.15\ \text{V}$	2.3	1.65 to 5.5				0.4	
		$I_{OL} = 400\ \mu\text{A}, V_{IB} \leq 0.15\ \text{V}$	3	1.65 to 5.5				0.55	
V_{OHB}	Port B output high voltage $I_{OH} = -20\ \mu\text{A}$ $V_{IA} \geq V_{CCA} - 0.2\ \text{V}$	1.2	1.65 to 5.5	$V_{CCB} \times 0.67$					V
V_{OLB}	Port B output low voltage	$I_{OL} = 220\ \mu\text{A}, V_{IA} \leq 0.15\ \text{V}$	1.2 to 3.6	1.65				0.4	V
		$I_{OL} = 300\ \mu\text{A}, V_{IA} \leq 0.15\ \text{V}$	1.2 to 3.6	2.3				0.4	
		$I_{OL} = 400\ \mu\text{A}, V_{IA} \leq 0.15\ \text{V}$	1.2 to 3.6	3				0.55	
		$I_{OL} = 620\ \mu\text{A}, V_{IA} \leq 0.15\ \text{V}$	1.2 to 3.6	4.5				0.55	
I_i	Input leakage current OE: $V_i = V_{CCI}$ or GND	1.2	1.65 to 5.5	-1		1		2	μA
I_{OZ}	High-impedance state output current A or B port	1.2	1.65 to 5.5	-1		1	-2	2	μA
I_{CCA}	V_{CCA} supply current $V_i = V_O = \text{Open}, I_O = 0$	1.2	1.65 to 5.5	1.5			-2	2	μA
		1.5 to 3.6	2.3 to 5.5				2		
		3.6	0				2		
		0	5.5				-1		
I_{CCB}	V_{CCB} supply current $V_i = V_O = \text{Open}, I_O = 0$	1.2	1.65 to 5.5	1.5					μA
		1.5 to 3.6	2.3 to 5.5				6		
		3.6	0				-1		
		0	5.5				1.2		
$I_{CCA} + I_{CCB}$	Combined supply current $V_i = V_{CCI}$ or GND, $I_O = 0$	1.2	2.3 to 5.5	3					μA
		1.5 to 3.6	2.3 to 5.5				8		
I_{CCZA}	High-impedance state V_{CCA} supply current $V_i = V_O = \text{Open}, I_O = 0, \text{OE} = \text{GND}$	1.2	1.65 to 5.5	0.05					μA
I_{CCZB}	High-impedance state V_{CCB} supply current $V_i = V_O = \text{Open}, I_O = 0, \text{OE} = \text{GND}$	1.2	1.65 to 5.5	4					μA
C_i	Input capacitance OE	3.3	3.3	4.5				5.5	pF
C_{io}	Input-to-output internal capacitance	A port	3.3	3.3	6			7	pF
		B port	3.3	3.3	5.5			6	

- (1) V_{CCO} is the V_{CC} associated with the output port.
- (2) V_{CCI} is the V_{CC} associated with the input port.
- (3) V_{CCA} must be less than or equal to V_{CCB} , and V_{CCA} must not exceed 3.6 V.

6.6 Timing Requirements: $V_{CCA} = 1.2\text{ V}$

 $T_A = 25^\circ\text{C}$, $V_{CCA} = 1.2\text{ V}$

			$V_{CCB}\text{ (V)}$				UNIT
			1.8 (TYP)	2.5 (TYP)	3.3 (TYP)	5 (TYP)	
Data rate	Push-pull		20	20	20	20	Mbps
	Open-drain		2	2	2	2	
t_w Pulse duration	Data inputs	Push-pull	50	50	50	50	ns
		Open-drain	500	500	500	500	

6.7 Timing Requirements: $V_{CCA} = 1.5\text{ V} \pm 0.1\text{ V}$

 over recommended operating free-air temperature range, $V_{CCA} = 1.5\text{ V} \pm 0.1\text{ V}$ (unless otherwise noted)

			$V_{CCB} = 1.8\text{ V} \pm 0.15\text{ V}$		$V_{CCB} = 2.5\text{ V} \pm 0.2\text{ V}$		$V_{CCB} = 3.3\text{ V} \pm 0.3\text{ V}$		$V_{CCB} = 5\text{ V} \pm 0.5\text{ V}$		UNIT
			MIN	MAX	MIN	MAX	MIN	MAX	MIN	MAX	
Data rate	Push-pull		40		60		60		50		Mbps
	Open-drain		2		2		2		2		
t_w Pulse duration	Data inputs	Push-pull	25		16.7		16.7		20		ns
		Open-drain	500		500		500		500		

6.8 Timing Requirements: $V_{CCA} = 1.8\text{ V} \pm 0.15\text{ V}$

 over recommended operating free-air temperature range, $V_{CCA} = 1.8\text{ V} \pm 0.15\text{ V}$ (unless otherwise noted)

			$V_{CCB} = 1.8\text{ V} \pm 0.15\text{ V}$		$V_{CCB} = 2.5\text{ V} \pm 0.2\text{ V}$		$V_{CCB} = 3.3\text{ V} \pm 0.3\text{ V}$		$V_{CCB} = 5\text{ V} \pm 0.5\text{ V}$		UNIT
			MIN	MAX	MIN	MAX	MIN	MAX	MIN	MAX	
Data rate	Push-pull		40		60		60		60		Mbps
	Open-drain		2		2		2		2		
t_w Pulse duration	Data inputs	Push-pull	25		16.7		16.7		16.7		ns
		Open-drain	500		500		500		500		

6.9 Timing Requirements: $V_{CCA} = 2.5\text{ V} \pm 0.2\text{ V}$

 over recommended operating free-air temperature range, $V_{CCA} = 2.5\text{ V} \pm 0.2\text{ V}$ (unless otherwise noted)

			$V_{CCB} = 2.5\text{ V} \pm 0.2\text{ V}$		$V_{CCB} = 3.3\text{ V} \pm 0.3\text{ V}$		$V_{CC} = 5\text{ V} \pm 0.5\text{ V}$		UNIT
			MIN	MAX	MIN	MAX	MIN	MAX	
Data rate	Push-pull		60		60		60		Mbps
	Open-drain		2		2		2		
t_w Pulse duration	Data inputs	Push-pull	16.7		16.7		16.7		ns
		Open-drain	500		500		500		

6.10 Timing Requirements: $V_{CCA} = 3.3\text{ V} \pm 0.3\text{ V}$

 over recommended operating free-air temperature range, $V_{CCA} = 3.3\text{ V} \pm 0.3\text{ V}$ (unless otherwise noted)

			$V_{CCB} = 3.3\text{ V} \pm 0.3\text{ V}$		$V_{CC} = 5\text{ V} \pm 0.5\text{ V}$		UNIT
			MIN	MAX	MIN	MAX	
Data rate	Push-pull		60		60		Mbps
	Open-drain		2		2		
t_w Pulse duration	Data inputs	Push-pull	16.7		16.7		ns
		Open-drain	500		500		

6.11 Switching Characteristics: $V_{CCA} = 1.2\text{ V}$

over operating free-air temperature range (unless otherwise noted)

PARAMETER	TEST CONDITIONS		$V_{CCB} = 1.8\text{ V}$ $\pm 0.15\text{ V}$			$V_{CCB} = 2.5\text{ V}$ $\pm 0.2\text{ V}$			$V_{CCB} = 3.3\text{ V}$ $\pm 0.3\text{ V}$			$V_{CCB} = 5\text{ V}$ $\pm 0.5\text{ V}$			UNIT
			MIN	TYP	MAX	MIN	TYP	MAX	MIN	TYP	MAX	MIN	TYP	MAX	
t_{PHL}	Propagation delay time (high-to-low output)	A-to-B	Push-pull driving	6.5			5.9			5.7			5.5	ns	
			Open-drain driving	11.9			11.1			11			11.1		
t_{PLH}	Propagation delay time (low-to-high output)	A-to-B	Push-pull driving	7.1			6.3			6.2			6.6	ns	
			Open-drain driving	293			236			197			152		
t_{PHL}	Propagation delay time (high-to-low output)	B-to-A	Push-pull driving	6.4			6			5.8			5.6	ns	
			Open-drain driving	8.5			6.8			6.2			5.9		
t_{PLH}	Propagation delay time (low-to-high output)	B-to-A	Push-pull driving	5.6			4.1			3.6			3.2	ns	
			Open-drain driving	312			248			192			132		
t_{en}	Enable time	OE-to-A or B	Push-pull driving	200			200			200			200	ns	
t_{dis}	Disable time	OE-to-A or B	Push-pull driving	16.8			13.9			13.2			13.5	ns	
t_{rA}	Input rise time	A-port rise time	Push-pull driving	7.9			6.7			6.5			6.4	ns	
			Open-drain driving	296			238			185			127		
t_{rB}	Input rise time	B-port rise time	Push-pull driving	6.3			3.3			1.8			1.5	ns	
			Open-drain driving	236			164			115			60		
t_{fA}	Input fall time	A-port fall time	Push-pull driving	5.8			4.8			4.3			3.8	ns	
			Open-drain driving	5.9			4.7			4.1			3.5		
t_{fB}	Input fall time	B-port fall time	Push-pull driving	4.6			2.8			2.2			1.9	ns	
			Open-drain driving	4.5			2.7			2.2			1.9		
$t_{SK(O)}$	Skew (time), output	Channel-to-channel skew	Push-pull driving	1			1			1			1	ns	
Maximum data rate	A or B	Push-pull driving	20			20			20				20	Mbps	
		Open-drain driving	2			2			2			2			

6.12 Switching Characteristics: $V_{CCA} = 1.5\text{ V} \pm 0.1\text{ V}$

over recommended operating free-air temperature range, $V_{CCA} = 1.5\text{ V} \pm 0.1\text{ V}$ (unless otherwise noted)

PARAMETER	TEST CONDITIONS		$V_{CCB} = 1.8\text{ V} \pm 0.15\text{ V}$		$V_{CCB} = 2.5\text{ V} \pm 0.2\text{ V}$		$V_{CCB} = 3.3\text{ V} \pm 0.3\text{ V}$		$V_{CCB} = 5\text{ V} \pm 0.5\text{ V}$		UNIT
			MIN	MAX	MIN	MAX	MIN	MAX	MIN	MAX	
t_{PHL} Propagation delay time (high-to-low output)	A-to-B	Push-pull driving	11		9.2		8.6		8.6		ns
		Open-drain driving	4	14.4	3.6	12.8	3.5	12.2	3.5	12	
t_{PLH} Propagation delay time (low-to-high output)	A-to-B	Push-pull driving	12		10		9.8		9.7		
		Open-drain driving	182	720	143	554	114	473	81	384	
t_{PHL} Propagation delay time (high-to-low output)	B-to-A	Push-pull driving	12.7		11.1		11		12		ns
		Open-drain driving	3.4	13.2	3.1	9.6	2.8	8.5	2.5	7.5	
t_{PLH} Propagation delay time (low-to-high output)	B-to-A	Push-pull driving	9.5		6.2		5.1		1.6		
		Open-drain driving	186	745	147	603	118	519	84	407	
t_{en} Enable time	OE-to-A or B	Push-pull driving	200		200		200		200		ns
t_{dis} Disable time	OE-to-A or B	Push-pull driving	28.1		22		20.1		19.6		ns
t_{rA} Input rise time	A-port rise time	Push-pull driving	3.5	13.1	3	9.8	3.1	9	3.2	8.3	ns
		Open-drain driving	147	982	115	716	92	592	66	481	
t_{rB} Input rise time	B-port rise time	Push-pull driving	2.9	11.4	1.9	7.4	0.9	4.7	0.7	2.6	ns
		Open-drain driving	135	1020	91	756	58	653	20	370	
t_{fA} Input fall time	A-port fall time	Push-pull driving	2.3	9.9	1.7	7.7	1.6	6.8	1.7	6	ns
		Open-drain driving	2.4	10	2.1	7.9	1.7	7	1.5	6.2	
t_{fB} Input fall time	B-port fall time	Push-pull driving	2	8.7	1.3	5.5	0.9	3.8	0.8	3.1	
		Open-drain driving	1.2	11.5	1.3	8.6	1	9.6	0.5	7.7	
$t_{SK(O)}$ Skew (time), output	Channel-to-channel skew	Push-pull driving	1		1	1	1.1		1		ns
Maximum data rate	A or B	Push-pull driving	40		60		60		50		Mbps
		Open-drain driving	2		2		2		2		

6.13 Switching Characteristics: $V_{CCA} = 1.8 \text{ V} \pm 0.15 \text{ V}$

over recommended operating free-air temperature range, $V_{CCA} = 1.8 \text{ V} \pm 0.15 \text{ V}$ (unless otherwise noted)

PARAMETER		TEST CONDITIONS		$V_{CCB} = 1.8 \text{ V} \pm 0.15 \text{ V}$		$V_{CCB} = 2.5 \text{ V} \pm 0.2 \text{ V}$		$V_{CCB} = 3.3 \text{ V} \pm 0.3 \text{ V}$		$V_{CCB} = 5 \text{ V} \pm 0.5 \text{ V}$		UNIT
				MIN	MAX	MIN	MAX	MIN	MAX	MIN	MAX	
t_{PHL}	Propagation delay time (high-to-low output)	A-to-B	Push-pull driving	8.2		6.4		5.7		5.6		ns
			Open-drain driving	3.6	11.4	3.2	9.9	3.1	9.3	3.1	8.9	
t_{PLH}	Propagation delay time (low-to-high output)	A-to-B	Push-pull driving	9		2.1		6.5		6.3		ns
			Open-drain driving	194	729	155	584	126	466	90	346	
t_{PHL}	Propagation delay time (high-to-low output)	B-to-A	Push-pull driving	9.8		8		7.4		7		ns
			Open-drain driving	3.4	12.1	2.8	8.5	2.5	7.3	2.1	6.2	
t_{PLH}	Propagation delay time (low-to-high output)	B-to-A	Push-pull driving	10.2		7		5.8		5		ns
			Open-drain driving	197	733	159	578	129	459	93	323	
t_{en}	Enable time	OE-to-A or B	Push-pull driving	200		200		200		200		ns
t_{dis}	Disable time	OE-to-A or B	Push-pull driving	25.1		18.8		16.5		15.3		ns
t_{rA}	Input rise time	A-port rise time	Push-pull driving	3.1	11.9	2.6	8.6	2.7	7.8	2.8	7.2	ns
			Open-drain driving	155	996	124	691	100	508	72	350	
t_{rB}	Input rise time	B-port rise time	Push-pull driving	2.8	10.5	1.8	7.2	1.2	5.2	0.7	2.7	ns
			Open-drain driving	132	1001	106	677	73	546	32	323	
t_{fA}	Input fall time	A-port fall time	Push-pull driving	2.1	8.8	1.6	6.6	1.4	5.7	1.4	4.9	ns
			Open-drain driving	2.2	9	1.7	6.7	1.4	5.8	1.2	5.2	
t_{fB}	Input fall time	B-port fall time	Push-pull driving	2	8.3	1.3	5.4	0.9	3.9	0.7	3	ns
			Open-drain driving	0.8	10.5	0.7	10.7	1	9.6	0.6	7.8	
$t_{SK(O)}$	Skew (time), output	Channel-to-channel skew	Push-pull driving	1		1		1		1		ns
	Maximum data rate	A or B	Push-pull driving	40		60		60		60		Mbps
			Open-drain driving	2		2		2		2		

6.14 Switching Characteristics: $V_{CCA} = 2.5 \text{ V} \pm 0.2 \text{ V}$

 over recommended operating free-air temperature range, $V_{CCA} = 2.5 \text{ V} \pm 0.2 \text{ V}$ (unless otherwise noted)

PARAMETER	TEST CONDITIONS		$V_{CCB} = 2.5 \text{ V} \pm 0.2 \text{ V}$		$V_{CCB} = 3.3 \text{ V} \pm 0.3 \text{ V}$		$V_{CCB} = 5 \text{ V} \pm 0.5 \text{ V}$		UNIT
			MIN	MAX	MIN	MAX	MIN	MAX	
t_{PHL} Propagation delay time (high-to-low output)	A -to-B	Push-pull driving		5		4		3.7	ns
		Open-drain driving	2.4	6.9	2.3	6.3	2.2	5.8	
t_{PLH} Propagation delay time (low-to-high output)	A -to-B	Push-pull driving		5.2		4.3		3.9	ns
		Open-drain driving	149	592	125	488	93	368	
t_{PHL} Propagation delay time (high-to-low output)	B-to-A	Push-pull driving		5.4		4.7		4.2	ns
		Open-drain driving	2.5	7.3	2.2	6	1.8	4.9	
t_{PLH} Propagation delay time (low-to-high output)	B-to-A	Push-pull driving		5.9		4.4		3.5	ns
		Open-drain driving	150	595	126	481	94	345	
t_{en} Enable time	OE-to-A or B	Push-pull driving		200		200		200	ns
t_{dis} Disable time	OE-to-A or B	Push-pull driving		15.7		12.9		11.2	ns
t_{rA} Input rise time	A-port rise time	Push-pull driving	2	7.3	2.1	6.4	2.2	5.8	ns
		Open-drain driving	110	692	93	529	68	369	
t_{rB} Input rise time	B-port rise time	Push-pull driving	1.8	6.5	1.3	5.1	0.7	3.4	ns
		Open-drain driving	107	693	79	483	41	304	
t_{fA} Input fall time	A-port fall time	Push-pull driving	1.5	5.7	1.2	4.7	1.3	3.8	ns
		Open-drain driving	1.5	5.6	1.2	4.7	1.1	4	
t_{fB} Input fall time	B-port fall time	Push-pull driving	1.4	5.4	0.9	4.1	0.7	3	ns
		Open-drain driving	0.4	14.2	0.5	19.4	0.4	3	
$t_{SK(O)}$ Skew (time), output	Channel-to-channel skew	Push-pull driving		1		1.2		1	ns
Maximum data rate	A or B	Push-pull driving	60		60		60		Mbps
		Open-drain driving	2		2		2		

6.15 Switching Characteristics: $V_{CCA} = 3.3\text{ V} \pm 0.3\text{ V}$

over recommended operating free-air temperature range, $V_{CCA} = 3.3\text{ V} \pm 0.3\text{ V}$ (unless otherwise noted)

PARAMETER	TEST CONDITIONS		$V_{CCB} = 3.3\text{ V} \pm 0.3\text{ V}$		$V_{CCB} = 5\text{ V} \pm 0.5\text{ V}$		UNIT
			MIN	MAX	MIN	MAX	
t_{PHL} Propagation delay time (high-to-low output)	A-to-B	Push-pull driving		3.8		3.1	ns
		Open-drain driving	2	5.3	1.9	4.8	
t_{PLH} Propagation delay time (low-to-high output)	A-to-B	Push-pull driving		3.9		3.5	
		Open-drain driving	111	439	87	352	
t_{PHL} Propagation delay time (high-to-low output)	B-to-A	Push-pull driving		4.2		3.8	ns
		Open-drain driving	2.1	5.5	1.7	4.5	
t_{PLH} Propagation delay time (low-to-high output)	A-to-B	Push-pull driving		3.8		4.3	
		Open-drain driving	112	449	86	339	
t_{en} Enable time	OE-to-A or B	Push-pull driving		200		200	ns
t_{dis} Disable time	OE-to-A or B	Push-pull driving		11.9		9.8	ns
t_{rA} Input rise time	A-port rise time	Push-pull driving	1.8	5.7	1.9	5	ns
		Open-drain driving	75	446	57	337	
t_{rB} Input rise time	B-port rise time	Push-pull driving	1.5	5	1	3.6	ns
		Open-drain driving	72	427	40	290	
t_{fA} Input fall time	A-port fall time	Push-pull driving	1.2	4.5	1.1	3.5	ns
		Open-drain driving	1.1	4.4	1	3.7	
t_{fB} Input fall time	B-port fall time	Push-pull driving	1.1	4.2	0.8	3.1	
		Open-drain driving	1	4.2	0.8	3.1	
$t_{SK(O)}$ Skew (time), output	Channel-to-channel skew	Push-pull driving		1		1	ns
Maximum data rate	A or B	Push-pull driving	60		60		Mbps
		Open-drain driving	2		2		

6.16 Operating Characteristics: $V_{CCA} = 1.2\text{ V}$ to 1.5 V , $V_{CCB} = 1.2\text{ V}$ to 1.5 V

$T_A = 25^\circ\text{C}$

PARAMETER	TEST CONDITIONS		$V_{CCA} = 1.2\text{ V}, V_{CCB} = 1.2\text{ V}$			$V_{CCA} = 1.2\text{ V}, V_{CCB} = 1.2\text{ V}$			$V_{CCA} = 1.5\text{ V}, V_{CCB} = 1.5\text{ V}$			UNIT
			MIN	TYP	MAX	MIN	TYP	MAX	MIN	TYP	MAX	
C_{pdA} Power dissipation capacitance	CL = 0 f = 10 MHz tr = tf = 1 ns	A-port input, B-port output	5.9			5.7			5.9			pF
		B-port input, A-port output	10.2			10.3			9.9			
C_{pdB} Power dissipation capacitance	OE = V_{CCA} (outputs enabled)	A-port input, B-port output	29.9			22.2			21.5			
		B-port input, A-port output	22.9			16.7			16.7			
C_{pdA} Power dissipation capacitance	CL = 0 f = 10 MHz tr = tf = 1 ns	A-port input, B-port output	0.01			0.01			0.01			pF
		B-port input, A-port output	0.06			0.01			0.01			
C_{pdB} Power dissipation capacitance	OE = V_{CCA} (outputs enabled)	A-port input, B-port output	0.06			0.01			0.01			
		B-port input, A-port output	0.06			0.01			0.01			

6.17 Operating Characteristics: $V_{CCA} = 1.8\text{ V}$ to 3.3 V , $V_{CCB} = 1.8\text{ V}$ to 3.3 V

$T_A = 25^\circ\text{C}$

PARAMETER	TEST CONDITIONS		$V_{CCA} = 1.8\text{ V}, V_{CCB} = 1.8\text{ V}$			$V_{CCA} = 2.5\text{ V}, V_{CCB} = 2.5\text{ V}$			$V_{CCA} = 2.5\text{ V}, V_{CCB} = 2.5\text{ V}$			$V_{CCA} = 3.3\text{ V}, V_{CCB} = 3.3\text{ V}$			UNIT
			MIN	TYP	MAX	MIN	TYP	MAX	MIN	TYP	MAX	MIN	TYP	MAX	
C_{pdA} Power dissipation capacitance	CL = 0 f = 10 MHz tr = tf = 1 ns	A-port input, B-port output	5.9			6.7			6.9			8			pF
		B-port input, A-port output	9.7			9.7			9.4			9.8			
C_{pdB} Power dissipation capacitance	OE = V_{CCA} (outputs enabled)	A-port input, B-port output	20.8			21			23.4			23			
		B-port input, A-port output	16.8			17.8			20.8			20.9			
C_{pdA} Power dissipation capacitance	CL = 0 f = 10 MHz tr = tf = 1 ns	A-port input, B-port output	0.01			0.01			0.01			0.01			pF
		B-port input, A-port output	0.01			0.01			0.01			0.01			
C_{pdB} Power dissipation capacitance	OE = V_{CCA} (outputs enabled)	A-port input, B-port output	0.01			0.01			0.03			0.02			
		B-port input, A-port output	0.01			0.01			0.03			0.02			

7 Typical Characteristics

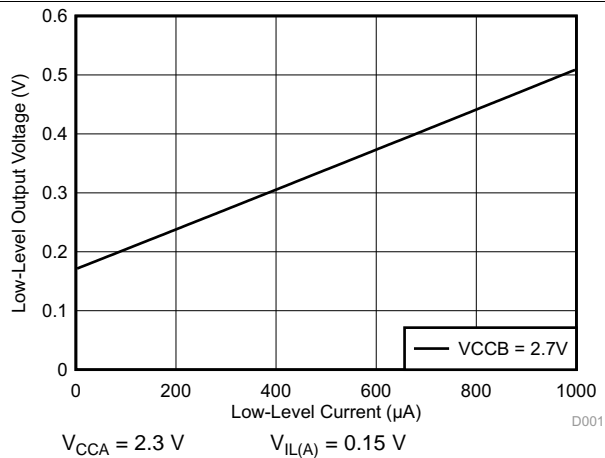

Figure 1. Low-Level Output Voltage ($V_{OL(Bx)}$) vs Low-Level Current ($I_{OL(Bx)}$)

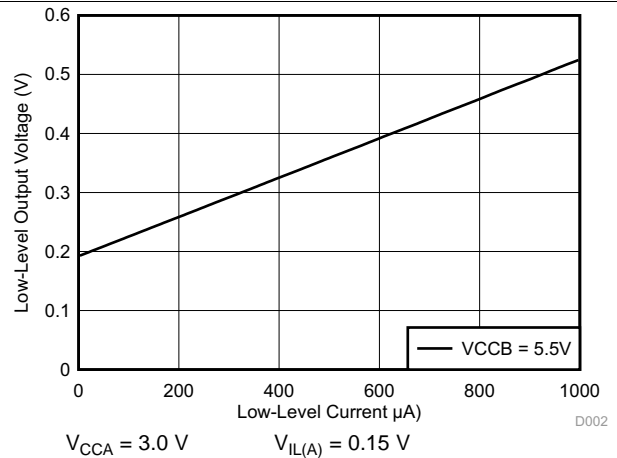

Figure 2. Low-Level Output Voltage ($V_{OL(Bx)}$) vs Low-Level Current ($I_{OL(Bx)}$)

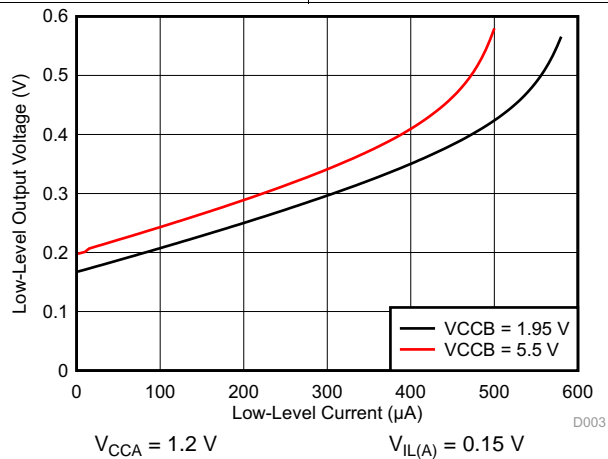
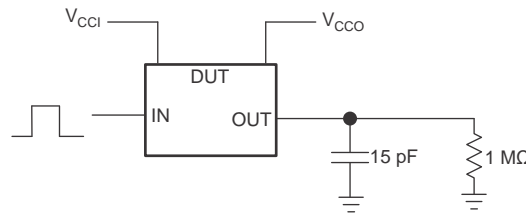

Figure 3. Low-Level Output Voltage ($V_{OL(Bx)}$) vs Low-Level Current ($I_{OL(Bx)}$)

8 Parameter Measurement Information

8.1 Load Circuits

Figure 4 shows the push-pull driver circuit used for measuring data rate, pulse duration, propagation delay, output rise-time and fall-time. Figure 5 shows the open-drain driver circuit used for measuring data rate, pulse duration, propagation delay, output rise-time and fall-time.



- (1) V_{CCI} is the V_{CC} associated with the input port.
- (2) V_{CCO} is the V_{CC} associated with the output port.

Figure 4. Data Rate, Pulse Duration, Propagation Delay, Output Rise-Time And Fall-Time Measurement Using a Push-Pull Driver

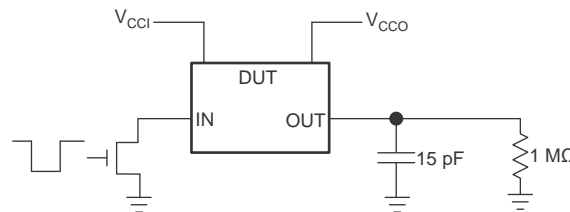

- (1) V_{CCI} is the V_{CC} associated with the input port.
- (2) V_{CCO} is the V_{CC} associated with the output port.

Figure 5. Data Rate (10 pF), Pulse Duration (10 pF), Propagation Delay, Output Rise-Time And Fall-Time Measurement Using an Open-Drain Driver

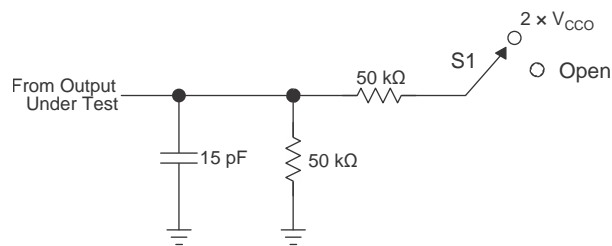

TEST	S1
t_{PZL} , t_{PLZ} (t_{dis})	$2 \times V_{CCO}$
t_{PHZ} , t_{PZH} (t_{en})	Open

- (1) t_{PLZ} and t_{PHZ} are the same as t_{dis} .
- (2) t_{PZL} and t_{PZH} are the same as t_{en} .

Figure 6. Load Circuit for Enable-Time and Disable-Time Measurement

8.2 Voltage Waveforms



图 7. Pulse Duration (Push-Pull)



图 8. Propagation Delay Times

9 Detailed Description

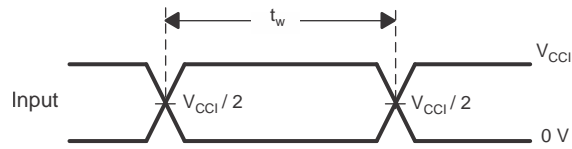
9.1 Overview

The TXS0108E device is a directionless voltage-level translator specifically designed for translating logic voltage levels. The A-port accepts I/O voltages ranging from 1.2 V to 3.6 V. The B-port accepts I/O voltages from 1.65 V to 5.5 V. The device uses pass gate architecture with edge rate accelerators (one shots) to improve the overall data rate. The pull-up resistors, commonly used in open-drain applications, have been conveniently integrated so that an external resistor is not needed. While this device is designed for open-drain applications, the device can also translate push-pull CMOS logic outputs.

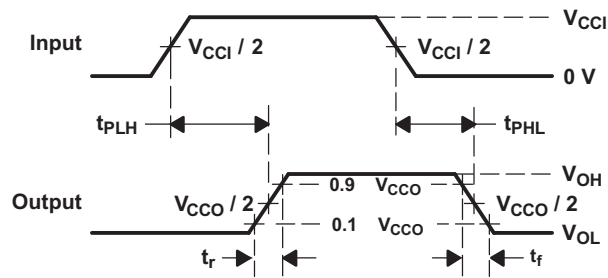
9.2 Functional Block Diagram



图 9. Functional Block Diagram

Each A-port I/O has a pull-up resistor (R_{PUA}) to V_{CCA} and each B-port I/O has a pull-up resistor (R_{PUB}) to V_{CCB} . R_{PUA} and R_{PUB} have a value of 40 k Ω when the output is driving low. R_{PUA} and R_{PUB} have a value of 4 k Ω when the output is driving high. R_{PUA} and R_{PUB} are disabled when OE = Low.

9.3 Feature Description

9.3.1 Architecture

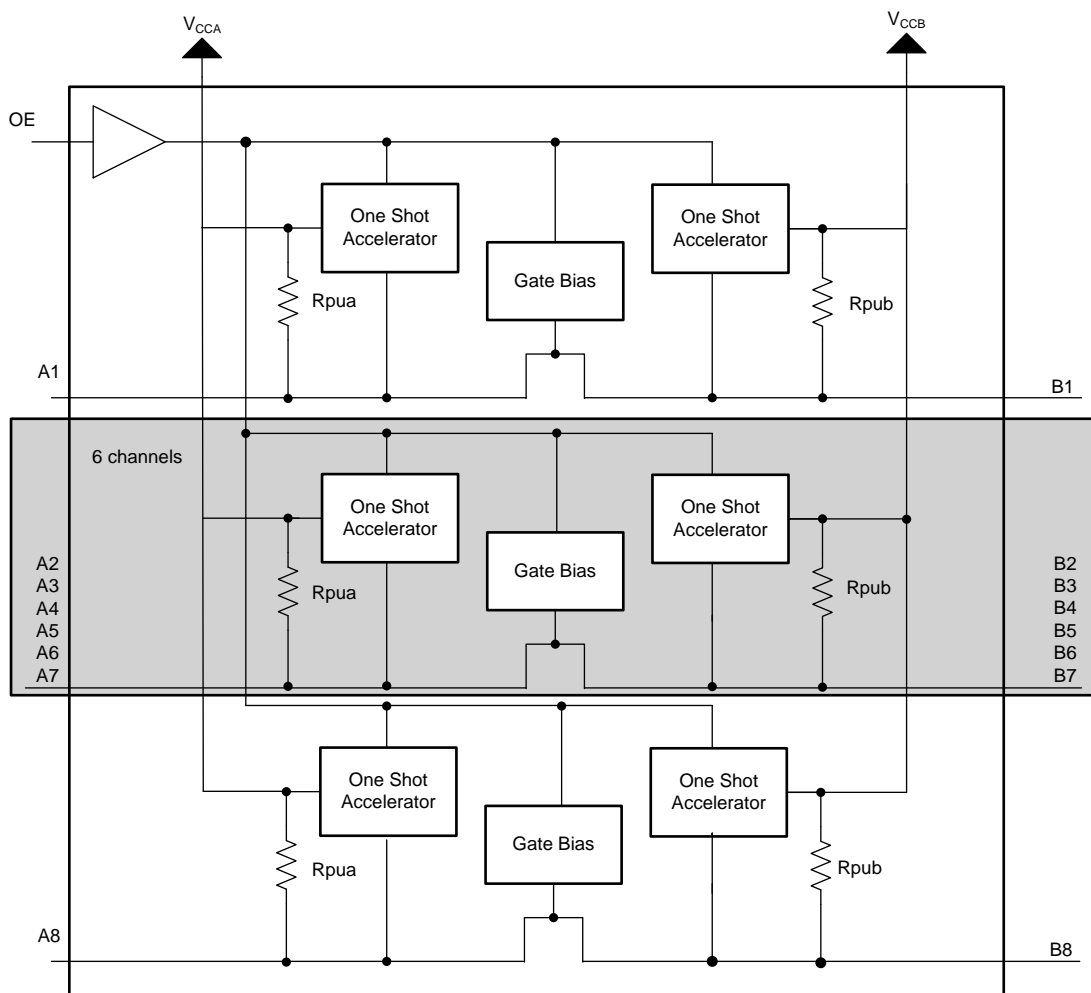
Figure 10 describes semi-buffered architecture design this application requires for both push-pull and open-drain mode. This application uses edge-rate accelerator circuitry (for both the high-to-low and low-to-high edges), a high-on-resistance N-channel pass-gate transistor (on the order of 300 Ω to 500 Ω) and pull-up resistors (to provide DC-bias and drive capabilities) to meet these requirements. This design needs no direction-control signal (to control the direction of data flow from A to B or from B to A). The resulting implementation supports both low-speed open-drain operation as well as high-speed push-pull operation.

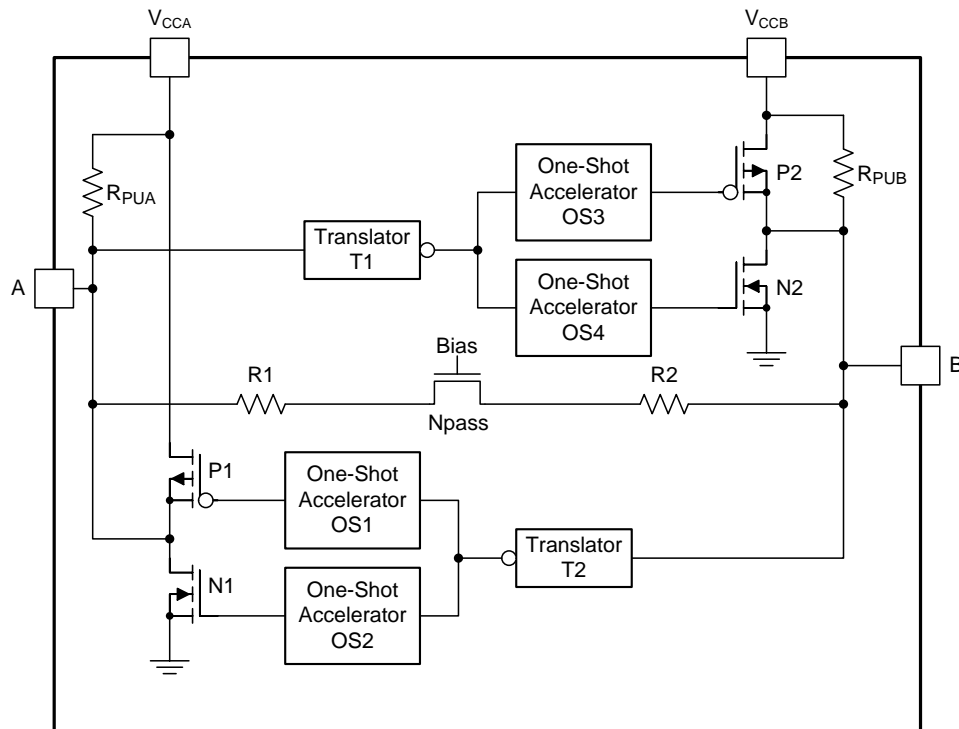

Figure 10. Architecture of a TXS0108E Cell

When transmitting data from A-ports to B-ports, during a rising edge the one-shot circuit (OS3) turns on the PMOS transistor (P2) for a short-duration which reduces the low-to-high transition time. Similarly, during a falling edge, when transmitting data from A to B, the one-shot circuit (OS4) turns on the N-channel MOSFET transistor (N2) for a short-duration which speeds up the high-to-low transition. The B-port edge-rate accelerator consists of one-shot circuits OS3 and OS4, transistors P2 and N2 and serves to rapidly force the B port high or low when a corresponding transition is detected on the A port.

When transmitting data from B- to A-ports, during a rising edge the one-shot circuit (OS1) turns on the PMOS transistor (P1) for a short-duration which reduces the low-to-high transition time. Similarly, during a falling edge, when transmitting data from B to A, the one-shot circuit (OS2) turns on NMOS transistor (N1) for a short-duration and this speeds up the high-to-low transition. The A-port edge-rate accelerator consists of one-shots OS1 and OS2, transistors P1 and N1 components and form the edge-rate accelerator and serves to rapidly force the A port high or low when a corresponding transition is detected on the B port.

Feature Description (continued)

9.3.2 Input Driver Requirements

The continuous DC-current *sinking* capability is determined by the external system-level open-drain (or push-pull) drivers that are interfaced to the TXS0108E I/O pins. Because the high bandwidth of these bidirectional I/O circuits is used to facilitate this fast change from an input to an output and an output to an input, they have a modest DC-current *sourcing* capability of hundreds of micro-amperes, as determined by the internal pull-up resistors.

The fall time (t_{fA} , t_{fB}) of a signal depends on the edge-rate and output impedance of the external device driving TXS0108E data I/Os, as well as the capacitive loading on the data lines.

Similarly, the t_{PHL} and maximum data rates also depend on the output impedance of the external driver. The values for t_{fA} , t_{fB} , t_{PHL} , and maximum data rates in the data sheet assume that the output impedance of the external driver is less than 50 Ω .

9.3.3 Output Load Considerations

TI recommends careful PCB layout practices with short PCB trace lengths to avoid excessive capacitive loading and to ensure that proper one-shot triggering takes place. PCB signal trace-lengths should be kept short enough such that the round trip delay of any reflection is less than the one-shot duration. This improves signal integrity by ensuring that any reflection sees a low impedance at the driver. The one-shot circuits have been designed to stay on for approximately 30 ns. The maximum capacitance of the lumped load that can be driven also depends directly on the one-shot duration. With very heavy capacitive loads, the one-shot can time-out before the signal is driven fully to the positive rail. The one-shot duration has been set to best optimize trade-offs between dynamic I_{CC} , load driving capability, and maximum bit-rate considerations. Both PCB trace length and connectors add to the capacitance of the TXS0108E output. Therefore, TI recommends that this lumped-load capacitance is considered in order to avoid one-shot retriggering, bus contention, output signal oscillations, or other adverse system-level affects.

9.3.4 Enable and Disable

The TXS0108E has an OE pin input that is used to disable the device by setting the OE pin low, which places all I/Os in the Hi-Z state. The disable time (t_{dis}) indicates the delay between the time when the OE pin goes low and when the outputs actually get disabled (Hi-Z). The enable time (t_{en}) indicates the amount of time the design must allow for the one-shot circuitry to become operational after the OE pin goes high.

9.3.5 Pull-up or Pull-down Resistors on I/O Lines

The TXS0108E has the smart pull-up resistors dynamically change value based on whether a low or a high is being passed through the I/O line. Each A-port I/O has a pull-up resistor (R_{PUA}) to V_{CCA} and each B-port I/O has a pull-up resistor (R_{PUB}) to V_{CCB} . R_{PUA} and R_{PUB} have a value of 40 k Ω when the output is driving low. R_{PUA} and R_{PUB} have a value of 4 k Ω when the output is driving high. R_{PUA} and R_{PUB} are disabled when OE = Low. This feature provides lower static power consumption (when the I/Os are passing a low), and supports lower V_{OL} values for the same size pass-gate transistor, and helps improve simultaneous switching performance.

9.4 Device Functional Modes

The TXS0108E device has two functional modes, enabled and disabled. To disable the device set the OE pin input low, which places all I/Os in a high impedance state. Setting the OE pin input high enables the device.

10 Application and Implementation

注

Information in the following applications sections is not part of the TI component specification, and TI does not warrant its accuracy or completeness. TI's customers are responsible for determining suitability of components for their purposes. Customers should validate and test their design implementation to confirm system functionality.

10.1 Application Information

The TXS0108E can be used in level-translation applications for interfacing devices or systems operating at different interface voltages with one another. The device is ideal for use in applications where an open-drain driver is connected to the data I/Os. The device is appropriate for applications where a push-pull driver is connected to the data I/Os, but the TXB0104 device, (SCES650) *4-Bit Bidirectional Voltage-Level Translator* might be a better option for such push-pull applications. The device is a semi-buffered auto-direction-sensing voltage translator design is optimized for translation applications (for example, MMC Card Interfaces) that require the system to start out in a low-speed open-drain mode and then switch to a higher speed push-pull mode.

10.2 Typical Application



图 11. Typical Application Circuit

10.2.1 Design Requirements

For this design example, use the parameters listed in 表 2. Ensure that $V_{CCA} \leq V_{CCB}$.

表 2. Design Parameters

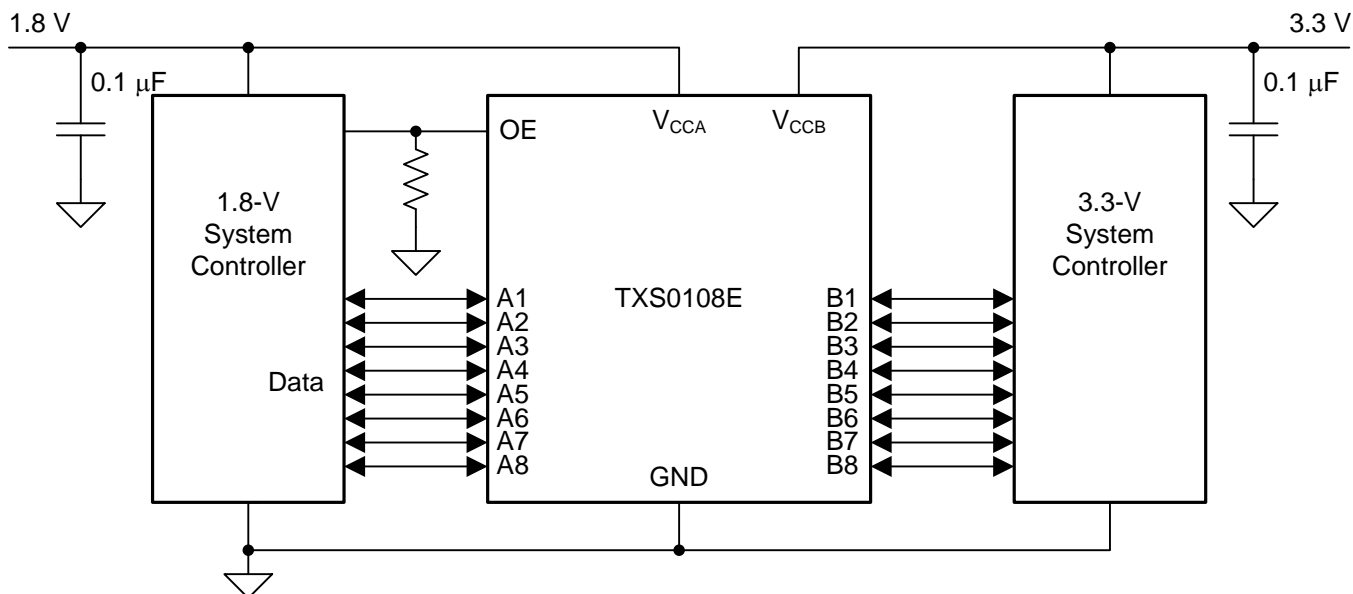
DESIGN PARAMETER	EXAMPLE VALUE
Input voltage range	1.4 V to 3.6 V
Output voltage range	1.65 V to 5.5 V

10.2.2 Detailed Design Procedure

To begin the design process, determine the following:

- Input voltage range
 - Use the supply voltage of the device that is driving the TXS0108E device to determine the input voltage range. For a valid logic high the value must exceed the V_{IH} of the input port. For a valid logic low the value

must be less than the V_{IL} of the input port.

- Output voltage range
 - Use the supply voltage of the device that the TXS0108E device is driving to determine the output voltage range.
 - The TXS0108E device has smart internal pull-up resistors. External pull-up resistors can be added to reduce the total RC of a signal trace if necessary.
- An external pull-down resistor decreases the output VOH and VOL. Use 式 1 to calculate the VOH as a result of an external pull-down resistor.

$$V_{OH} = V_{CCX} \times R_{PD} / (R_{PD} + 4 \text{ k}\Omega) \quad (1)$$

10.2.3 Application Curves

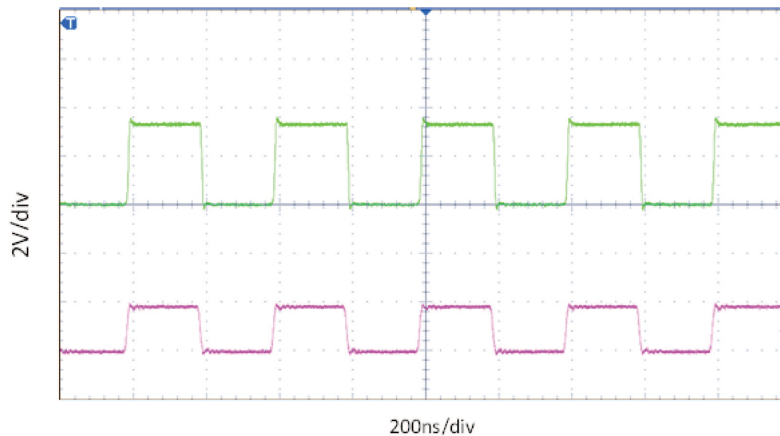

$$V_{CCA} = 1.8 \text{ V}$$

$$V_{CCB} = 3.3 \text{ V}$$

图 12. Level-Translation of a 2.5-MHz Signal

11 Power Supply Recommendations

During operation, ensure that $V_{CCA} \leq V_{CCB}$ at all times. The sequencing of each power supply will not damage the device during the power up operation, so either power supply can be ramped up first. The output-enable (OE) input circuit is designed so that it is supplied by V_{CCA} and when the (OE) input is low, all outputs are placed in the high-impedance state. To ensure the high-impedance state of the outputs during power up or power down, the OE input pin must be tied to GND through a pull-down resistor and must not be enabled until V_{CCA} and V_{CCB} are fully ramped and stable. The minimum value of the pull-down resistor to ground is determined by the current-sourcing capability of the driver.

12 Layout

12.1 Layout Guidelines

To ensure reliability of the device, following common printed-circuit board layout guidelines is recommended.

- Bypass capacitors should be used on power supplies. Place the capacitors as close as possible to the V_{CCA} , V_{CCB} pin and GND pin.
- Short trace lengths should be used to avoid excessive loading.
- PCB signal trace-lengths must be kept short enough so that the round-trip delay of any reflection is less than the one shot duration, approximately 30 ns, ensuring that any reflection encounters low impedance at the source driver.

12.2 Layout Example

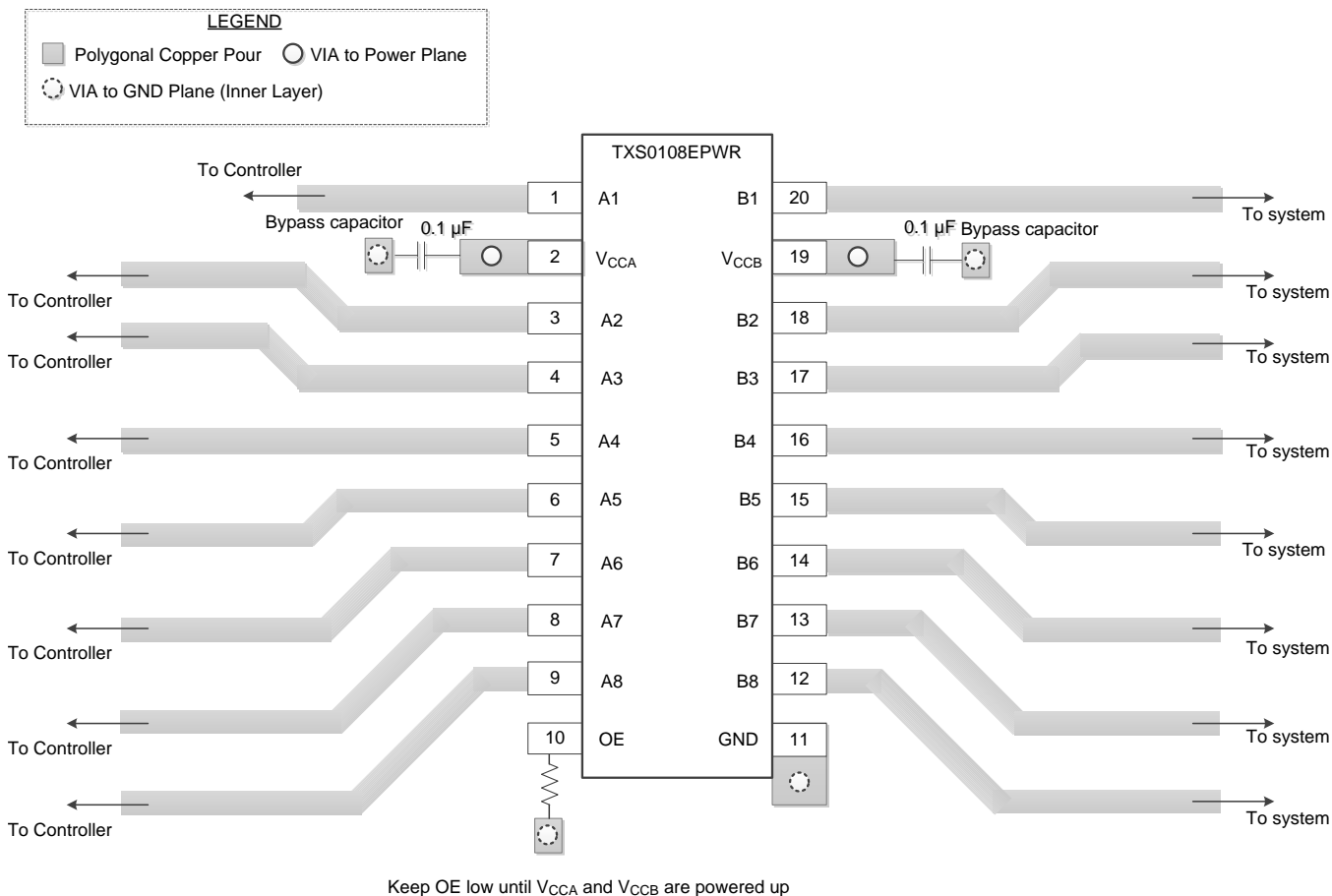

13. Layout Example

13 デバイスおよびドキュメントのサポート

13.1 コミュニティ・リソース

The following links connect to TI community resources. Linked contents are provided "AS IS" by the respective contributors. They do not constitute TI specifications and do not necessarily reflect TI's views; see TI's [Terms of Use](#).

TI E2E™オンライン・コミュニティ *TIのE2E (Engineer-to-Engineer)* コミュニティ。エンジニア間の共同作業を促進するために開設されたものです。e2e.ti.comでは、他のエンジニアに質問し、知識を共有し、アイデアを検討して、問題解決に役立てることができます。

設計サポート *TIの設計サポート* 役に立つE2Eフォーラムや、設計サポート・ツールをすばやく見つけることができます。技術サポート用の連絡先情報も参照できます。

13.2 商標

E2E is a trademark of Texas Instruments.
All other trademarks are the property of their respective owners.

13.3 静電気放電に関する注意事項



これらのデバイスは、限定的なESD(静電破壊)保護機能を内蔵しています。保存時または取り扱い時は、MOSゲートに対する静電破壊を防止するために、リード線同士をショートさせておくか、デバイスを導電フォームに入れる必要があります。

13.4 Glossary

[SLYZ022](#) — *TI Glossary*.

This glossary lists and explains terms, acronyms, and definitions.

14 メカニカル、パッケージ、および注文情報

以降のページには、メカニカル、パッケージ、および注文に関する情報が記載されています。この情報は、そのデバイスについて利用可能な最新のデータです。このデータは予告なく変更されることがあり、ドキュメントが改訂される場合もあります。本データシートのブラウザ版を使用されている場合は、画面左側の説明をご覧ください。

重要なお知らせと免責事項

TI は、技術データと信頼性データ(データシートを含みます)、設計リソース(リファレンス・デザインを含みます)、アプリケーションや設計に関する各種アドバイス、Web ツール、安全性情報、その他のリソースを、欠陥が存在する可能性のある「現状のまま」提供しており、商品性および特定目的に対する適合性の黙示保証、第三者の知的財産権の非侵害保証を含むいかなる保証も、明示的または黙示的にかかわらず拒否します。

これらのリソースは、TI 製品を使用する設計の経験を積んだ開発者への提供を意図したものです。(1) お客様のアプリケーションに適した TI 製品の選定、(2) お客様のアプリケーションの設計、検証、試験、(3) お客様のアプリケーションが適用される各種規格や、その他のあらゆる安全性、セキュリティ、またはその他の要件を満たしていることを確実にする責任を、お客様のみが単独で負うものとします。上記の各種リソースは、予告なく変更される可能性があります。これらのリソースは、リソースで説明されている TI 製品を使用するアプリケーションの開発の目的でのみ、TI はその使用をお客様に許諾します。これらのリソースに関して、他の目的で複製することや掲載することは禁止されています。TI や第三者の知的財産権のライセンスが付与されている訳ではありません。お客様は、これらのリソースを自身で使用した結果発生するあらゆる申し立て、損害、費用、損失、責任について、TI およびその代理人を完全に補償するものとし、TI は一切の責任を拒否します。

TI の製品は、TI の販売条件 (www.tij.co.jp/ja-jp/legal/termssofsale.html)、または ti.com やかかる TI 製品の関連資料などのいずれかを通じて提供する適用可能な条項の下で提供されています。TI がこれらのリソースを提供することは、適用される TI の保証または他の保証の放棄の拡大や変更を意味するものではありません。

Copyright © 2019, Texas Instruments Incorporated

日本語版 日本テキサス・インスツルメンツ株式会社

PACKAGING INFORMATION

Orderable Device	Status (1)	Package Type	Package Drawing	Pins	Package Qty	Eco Plan (2)	Lead/Ball Finish (6)	MSL Peak Temp (3)	Op Temp (°C)	Device Marking (4/5)	Samples
TXS0108ENMER	ACTIVE	NFBGA	NME	20	2500	Green (RoHS & no Sb/Br)	SNAGCU	Level-2-260C-1 YEAR	-40 to 85	2APW	Samples
TXS0108EPWR	ACTIVE	TSSOP	PW	20	2000	Green (RoHS & no Sb/Br)	NIPDAU	Level-1-260C-UNLIM	-40 to 85	YF08E	Samples
TXS0108EPWRG4	ACTIVE	TSSOP	PW	20	2000	Green (RoHS & no Sb/Br)	NIPDAU	Level-1-260C-UNLIM	-40 to 85	YF08E	Samples
TXS0108ERGYR	ACTIVE	VQFN	RGY	20	3000	Green (RoHS & no Sb/Br)	NIPDAU	Level-2-260C-1 YEAR	-40 to 85	YF08E	Samples
TXS0108EZXYR	ACTIVE	BGA MICROSTAR JUNIOR	ZXY	20	2500	Green (RoHS & no Sb/Br)	SNAGCU	Level-1-260C-UNLIM	-40 to 85	YF08E	Samples

(1) The marketing status values are defined as follows:

ACTIVE: Product device recommended for new designs.

LIFEBUY: TI has announced that the device will be discontinued, and a lifetime-buy period is in effect.

NRND: Not recommended for new designs. Device is in production to support existing customers, but TI does not recommend using this part in a new design.

PREVIEW: Device has been announced but is not in production. Samples may or may not be available.

OBSOLETE: TI has discontinued the production of the device.

(2) **RoHS:** TI defines "RoHS" to mean semiconductor products that are compliant with the current EU RoHS requirements for all 10 RoHS substances, including the requirement that RoHS substance do not exceed 0.1% by weight in homogeneous materials. Where designed to be soldered at high temperatures, "RoHS" products are suitable for use in specified lead-free processes. TI may reference these types of products as "Pb-Free".

RoHS Exempt: TI defines "RoHS Exempt" to mean products that contain lead but are compliant with EU RoHS pursuant to a specific EU RoHS exemption.

Green: TI defines "Green" to mean the content of Chlorine (Cl) and Bromine (Br) based flame retardants meet JS709B low halogen requirements of <=1000ppm threshold. Antimony trioxide based flame retardants must also meet the <=1000ppm threshold requirement.

(3) MSL, Peak Temp. - The Moisture Sensitivity Level rating according to the JEDEC industry standard classifications, and peak solder temperature.

(4) There may be additional marking, which relates to the logo, the lot trace code information, or the environmental category on the device.

(5) Multiple Device Markings will be inside parentheses. Only one Device Marking contained in parentheses and separated by a "~" will appear on a device. If a line is indented then it is a continuation of the previous line and the two combined represent the entire Device Marking for that device.

(6) Lead/Ball Finish - Orderable Devices may have multiple material finish options. Finish options are separated by a vertical ruled line. Lead/Ball Finish values may wrap to two lines if the finish value exceeds the maximum column width.

Important Information and Disclaimer: The information provided on this page represents TI's knowledge and belief as of the date that it is provided. TI bases its knowledge and belief on information provided by third parties, and makes no representation or warranty as to the accuracy of such information. Efforts are underway to better integrate information from third parties. TI has taken and continues to take reasonable steps to provide representative and accurate information but may not have conducted destructive testing or chemical analysis on incoming materials and chemicals. TI and TI suppliers consider certain information to be proprietary, and thus CAS numbers and other limited information may not be available for release.

In no event shall TI's liability arising out of such information exceed the total purchase price of the TI part(s) at issue in this document sold by TI to Customer on an annual basis.

TAPE AND REEL INFORMATION



QUADRANT ASSIGNMENTS FOR PIN 1 ORIENTATION IN TAPE



*All dimensions are nominal

Device	Package Type	Package Drawing	Pins	SPQ	Reel Diameter (mm)	Reel Width W1 (mm)	A0 (mm)	B0 (mm)	K0 (mm)	P1 (mm)	W (mm)	Pin1 Quadrant
TXS0108EPWR	TSSOP	PW	20	2000	330.0	16.4	6.95	7.0	1.4	8.0	16.0	Q1
TXS0108ERGYR	VQFN	RGY	20	3000	330.0	12.4	3.8	4.8	1.6	8.0	12.0	Q1
TXS0108EZXYR	BGA MICROSTAR JUNIOR	ZXY	20	2500	330.0	12.4	2.75	3.45	1.05	4.0	12.0	Q2

TAPE AND REEL BOX DIMENSIONS



*All dimensions are nominal

Device	Package Type	Package Drawing	Pins	SPQ	Length (mm)	Width (mm)	Height (mm)
TXS0108EPWR	TSSOP	PW	20	2000	367.0	367.0	38.0
TXS0108ERGYR	VQFN	RGY	20	3000	367.0	367.0	35.0
TXS0108EZXYR	BGA MICROSTAR JUNIOR	ZXY	20	2500	350.0	350.0	43.0

PW (R-PDSO-G20)

PLASTIC SMALL OUTLINE

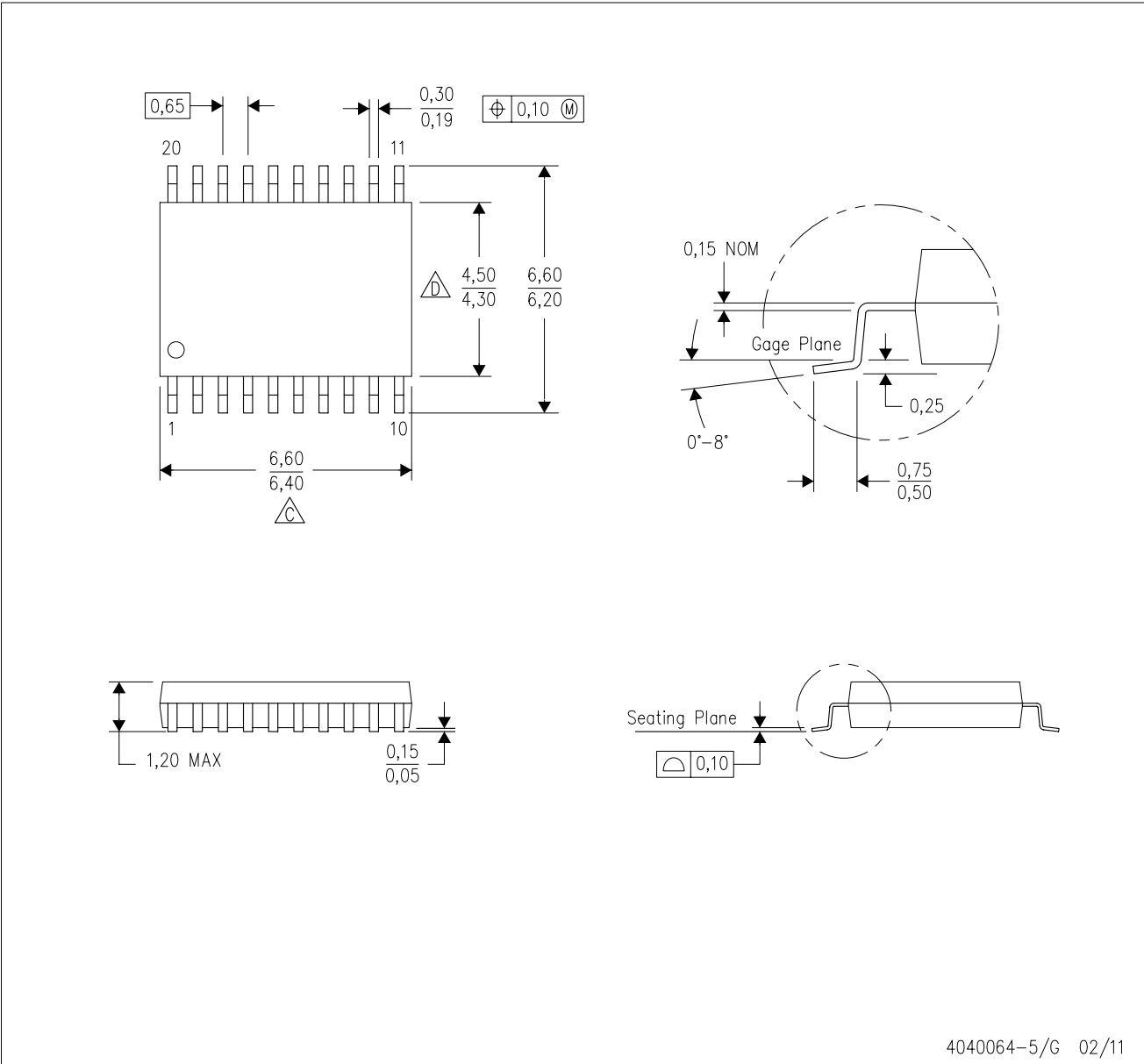

- NOTES:
- A. All linear dimensions are in millimeters. Dimensioning and tolerancing per ASME Y14.5M-1994.
 - B. This drawing is subject to change without notice.
 - C. Body length does not include mold flash, protrusions, or gate burrs. Mold flash, protrusions, or gate burrs shall not exceed 0,15 each side.
 - D. Body width does not include interlead flash. Interlead flash shall not exceed 0,25 each side.
 - E. Falls within JEDEC MO-153

PW (R-PDSO-G20)

PLASTIC SMALL OUTLINE



- NOTES:
- A. All linear dimensions are in millimeters.
 - B. This drawing is subject to change without notice.
 - C. Publication IPC-7351 is recommended for alternate design.
 - D. Laser cutting apertures with trapezoidal walls and also rounding corners will offer better paste release. Customers should contact their board assembly site for stencil design recommendations. Refer to IPC-7525 for other stencil recommendations.
 - E. Customers should contact their board fabrication site for solder mask tolerances between and around signal pads.

GENERIC PACKAGE VIEW

RGY 20

VQFN - 1 mm max height

3.5 x 4.5, 0.5 mm pitch

PLASTIC QUAD FGLATPACK - NO LEAD

This image is a representation of the package family, actual package may vary.
Refer to the product data sheet for package details.

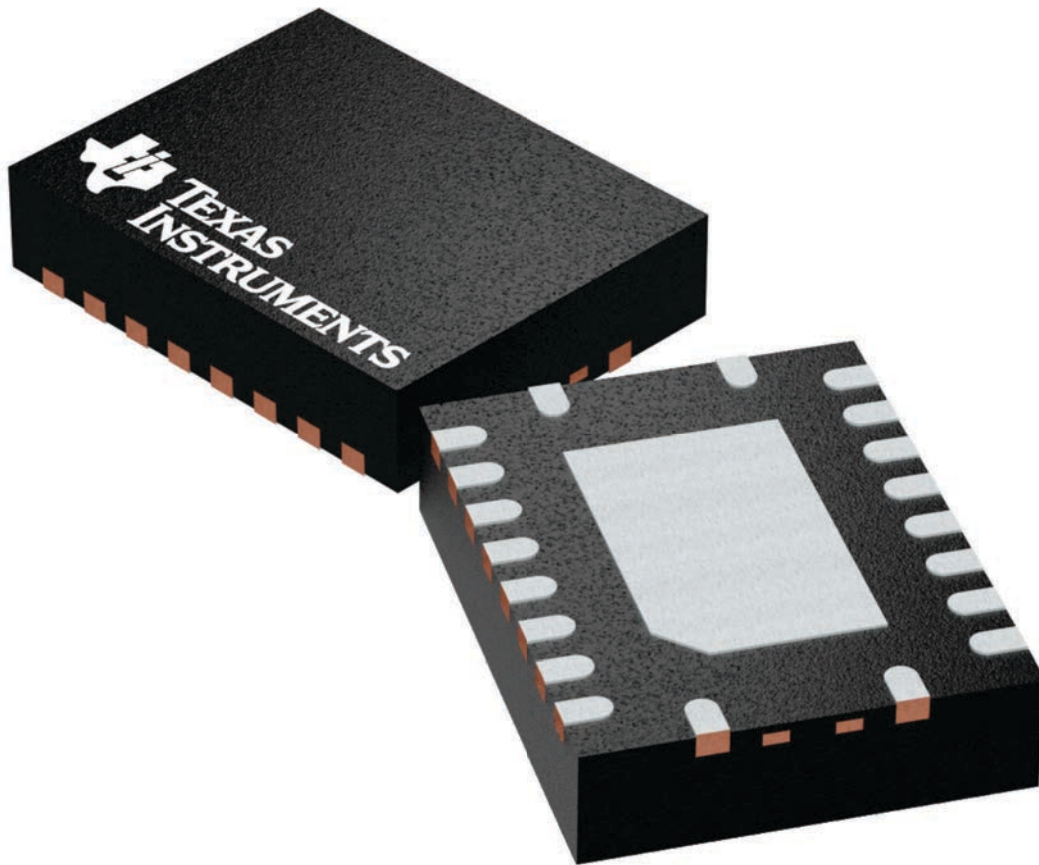

4225264/A

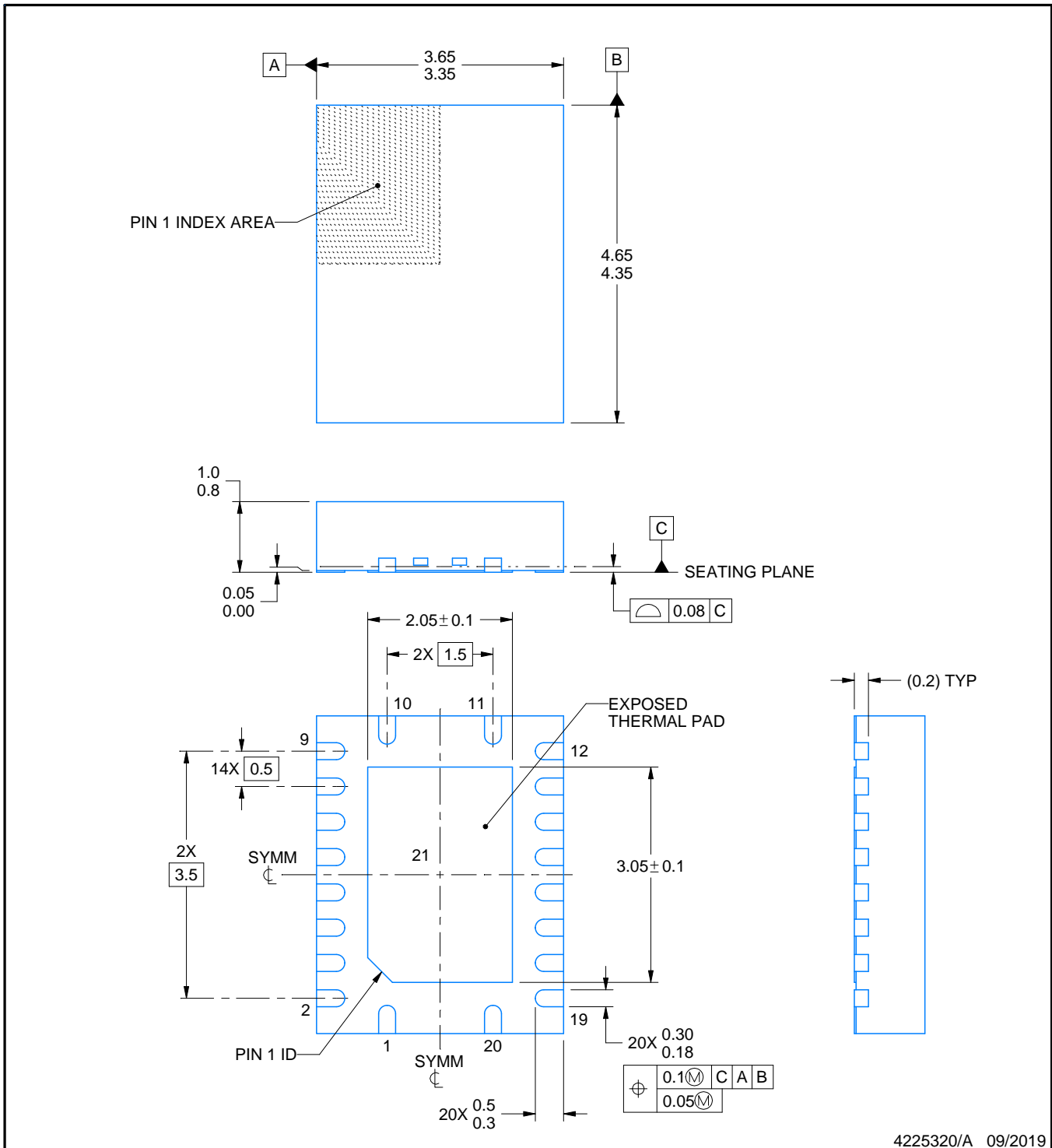

4225320/A 09/2019

NOTES:

1. All linear dimensions are in millimeters. Any dimensions in parenthesis are for reference only. Dimensioning and tolerancing per ASME Y14.5M.
2. This drawing is subject to change without notice.
3. The package thermal pad must be soldered to the printed circuit board for thermal and mechanical performance.

EXAMPLE BOARD LAYOUT

RGY0020A

VQFN - 1 mm max height

PLASTIC QUAD FLATPACK - NO LEAD



LAND PATTERN EXAMPLE
EXPOSED METAL SHOWN
SCALE:18X



SOLDER MASK DETAILS

4225320/A 09/2019

NOTES: (continued)

- This package is designed to be soldered to a thermal pad on the board. For more information, see Texas Instruments literature number SLUA271 (www.ti.com/lit/slua271).
- Vias are optional depending on application, refer to device data sheet. If any vias are implemented, refer to their locations shown on this view. It is recommended that vias under paste be filled, plugged or tented.

EXAMPLE STENCIL DESIGN

RGY0020A

VQFN - 1 mm max height

PLASTIC QUAD FLATPACK - NO LEAD

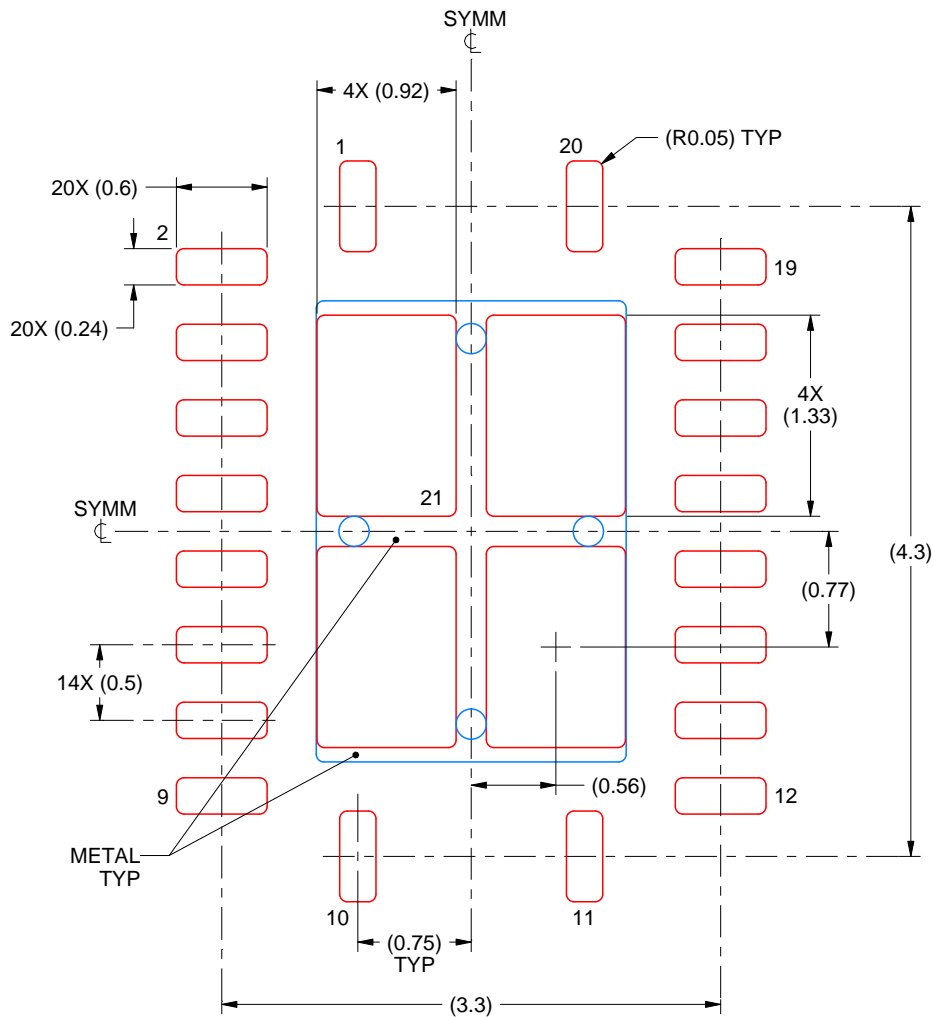

SOLDER PASTE EXAMPLE
 BASED ON 0.125 mm THICK STENCIL

EXPOSED PAD 21
 78% PRINTED SOLDER COVERAGE BY AREA UNDER PACKAGE
 SCALE:20X

4225320/A 09/2019

NOTES: (continued)

6. Laser cutting apertures with trapezoidal walls and rounded corners may offer better paste release. IPC-7525 may have alternate design recommendations.

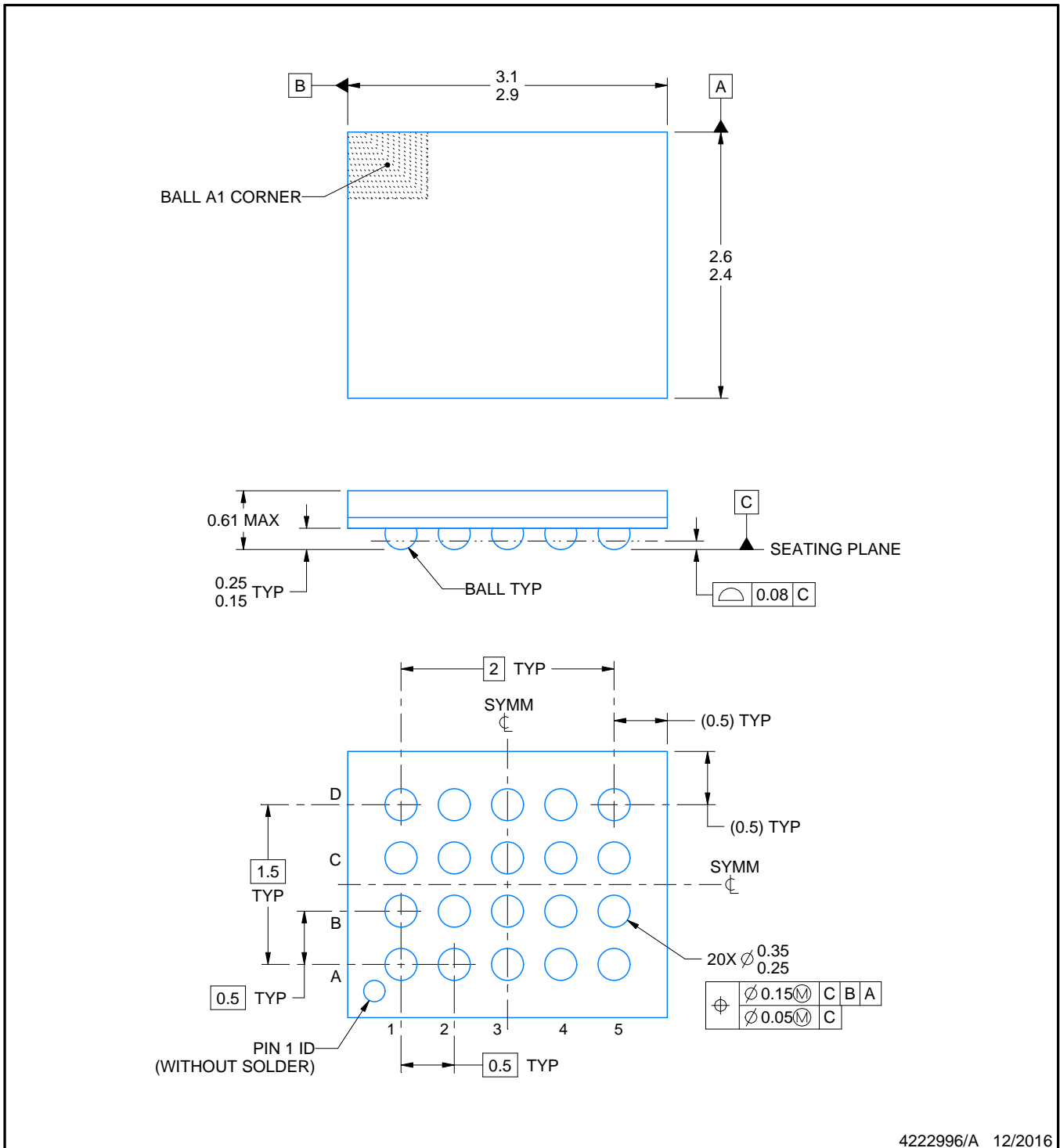
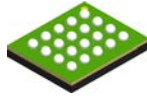

4222996/A 12/2016

NOTES:

1. All linear dimensions are in millimeters. Any dimensions in parenthesis are for reference only. Dimensioning and tolerancing per ASME Y14.5M.
2. This drawing is subject to change without notice.

EXAMPLE BOARD LAYOUT

ZXY0020A

VFBGA - 0.61 mm max height

PLASTIC BALL GRID ARRAY

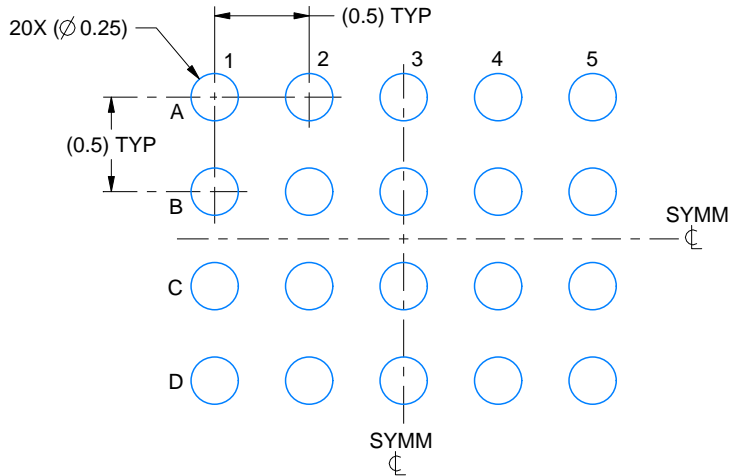

LAND PATTERN EXAMPLE
EXPOSED METAL SHOWN
SCALE:25X

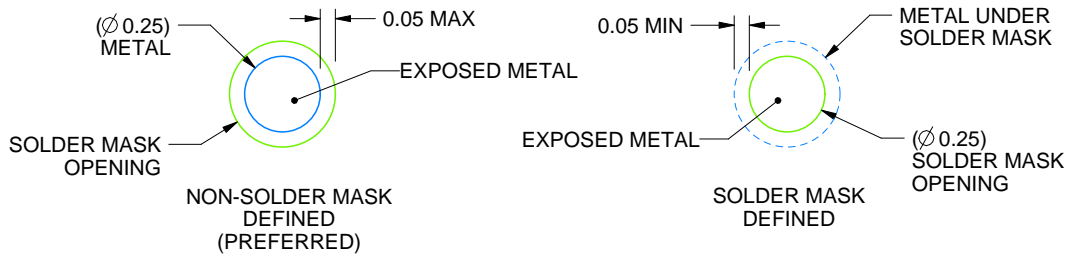

SOLDER MASK DETAILS
NOT TO SCALE

4222996/A 12/2016

NOTES: (continued)

- Final dimensions may vary due to manufacturing tolerance considerations and also routing constraints. For information, see Texas Instruments literature number SPRAA99 (www.ti.com/lit/spraa99).

EXAMPLE STENCIL DESIGN

ZXY0020A

VFBGA - 0.61 mm max height

PLASTIC BALL GRID ARRAY

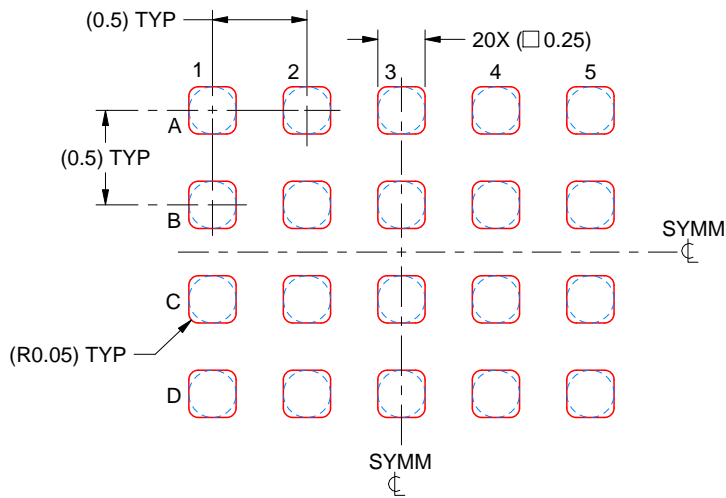

SOLDER PASTE EXAMPLE
BASED ON 0.1 mm THICK STENCIL
SCALE: 25X

4222996/A 12/2016

NOTES: (continued)

4. Laser cutting apertures with trapezoidal walls and rounded corners may offer better paste release.

重要なお知らせと免責事項

TI は、技術データと信頼性データ(データシートを含みます)、設計リソース(リファレンス・デザインを含みます)、アプリケーションや設計に関する各種アドバイス、Web ツール、安全性情報、その他のリソースを、欠陥が存在する可能性のある「現状のまま」提供しており、商品性および特定目的に対する適合性の黙示保証、第三者の知的財産権の非侵害保証を含むいかなる保証も、明示的または黙示的にかかわらず拒否します。

これらのリソースは、TI 製品を使用する設計の経験を積んだ開発者への提供を意図したものです。(1) お客様のアプリケーションに適した TI 製品の選定、(2) お客様のアプリケーションの設計、検証、試験、(3) お客様のアプリケーションが適用される各種規格や、その他のあらゆる安全性、セキュリティ、またはその他の要件を満たしていることを確実にする責任を、お客様のみが単独で負うものとします。上記の各種リソースは、予告なく変更される可能性があります。これらのリソースは、リソースで説明されている TI 製品を使用するアプリケーションの開発の目的でのみ、TI はその使用をお客様に許諾します。これらのリソースに関して、他の目的で複製することや掲載することは禁止されています。TI や第三者の知的財産権のライセンスが付与されている訳ではありません。お客様は、これらのリソースを自身で使用した結果発生するあらゆる申し立て、損害、費用、損失、責任について、TI およびその代理人を完全に補償するものとし、TI は一切の責任を拒否します。

TI の製品は、TI の販売条件 (www.tij.co.jp/ja-jp/legal/termsofsale.html)、または ti.com やかかる TI 製品の関連資料などのいずれかを通じて提供する適用可能な条項の下で提供されています。TI がこれらのリソースを提供することは、適用される TI の保証または他の保証の放棄の拡大や変更を意味するものではありません。

Copyright © 2020, Texas Instruments Incorporated

日本語版 日本テキサス・インスツルメンツ株式会社