



2111 Comprehensive Drive

Aurora, Illinois 60505

Phone: 630-851-4722

Fax: 630-851-5040

www.conwin.com

US Headquarters:

630-851-4722

European Headquarters:

+353-61-472221

Low Jitter V7223T Series LVC MOS VCXO

CONNOR WINFIELD



Description

The Connor-Winfield V7223T Series models are 3.3V SMT 5.0x3.2mm voltage controlled crystal oscillators (VCXOs) with ultra low jitter. With LVC MOS outputs, the V7223T series is designed for PLL applications requiring high performance and low noise.



Features:

- 3.3V Operation
- Low Jitter 60fs RMS typical
- Absolute Pull Range: ± 50 ppm
- Pin 1 Input Impedance 10M ohm
- 5.0x3.2mm Surface Mount Package
- Tape and Reel Packaging
- RoHS Compliant / Lead Free

Absolute Maximum Ratings

Parameter	Minimum	Nominal	Maximum	Units	Notes
Storage Temperature	-55	-	125	°C	
Supply Voltage (Vdd)	-0.5	-	4.6	Vdc	
Control Voltage (Vc)	-0.5	-	Vdd+0.5	Vdc	

Operating Specifications

Parameter	Minimum	Nominal	Maximum	Units	Notes
Center Frequency (Fo)	50	-	156.25	MHz	
Operating Temperature Range	-40	-	85	°C	
Supply Voltage (Vdd)	3.135	3.3	3.465	Vdc	
Supply Current (Idd)	-	-	25	mA	
Period Jitter RMS	-	3	5	ps RMS	
Integrated Phase Jitter (BW=12kHz to 20MHz)					
Fo=80MHz		100		fs RMS	
Fo=100MHz		60		fs RMS	
Fo=125MHz		60		fs RMS	
Fo=156.25MHz		60		fs RMS	
Typical Phase Noise for 100MHz					
SSB Phase Noise at 10Hz offset	-	-70	-	dBc/Hz	
SSB Phase Noise at 100Hz offset	-	-105	-	dBc/Hz	
SSB Phase Noise at 1kHz offset	-	-130	-	dBc/Hz	
SSB Phase Noise at 10kHz offset	-	-148	-	dBc/Hz	
SSB Phase Noise at 100kHz offset	-	-158	-	dBc/Hz	
SSB Phase Noise at 1MHz offset	-	-163	-	dBc/Hz	
SSB Phase Noise at 10MHz offset	-	-164	-	dBc/Hz	

Input Characteristics

Parameter	Minimum	Nominal	Maximum	Units	Notes
Control Voltage Range (Vc)	0.3	1.65	3.0	Vdc	
Typical Slope (Vc=1.65Vdc)	-	65	-	ppm/V	
Absolute Pull Range (APR)					
Fo = 50MHz to 125MHz	± 50	-	-	ppm	1
Fo > 125MHz	± 30	-	-	ppm	1
Monotonic Linearity	-10	-	10	%	
DC Input Resistance (Pad 1)	-	10M	-	Ohm	
Modulation Bandwidth (3dB)	25	-	-	kHz	
Enable / Disable Function (O/E)					
Enable Input Voltage - High (Vih)	2.4	-	-	Vdc	2
Disable Input Voltage - Low (Vil)	-	-	0.4		

LVC MOS Output Characteristics

Parameter	Minimum	Nominal	Maximum	Units	Notes
Load	-	-	15	pF	
Voltage High (Voh)	0.9*Vdd	-	-	Vdc	
Low (Vol)	-	-	0.1*Vdd	Vdc	
Duty Cycle at 50% Level	45	50	55	%	
Rise / Fall Time 20% to 80%	-	0.5	2.0	nS	

Notes:

1. Absolute pull range (APR) is the minimum guaranteed pull range of the VCXO under all conditions over the lifetime operation. Including calibration @ 25°C, frequency vs. change in temperature, frequency vs. change in supply voltage, frequency vs. change in load, shock and vibration and aging for ten years. The APR is referenced to Fo, Positive Transfer Function.
2. Output is enabled with no connection on Pad 2. When oscillator is disabled the output is high impedance.



Package Characteristics

Package	Hermetically sealed, ceramic package with grounded metal cover.
Soldering Process	RoHS compliant / lead free, see solder profile on page 3.

Typical Phase Noise V7223T-100.0M

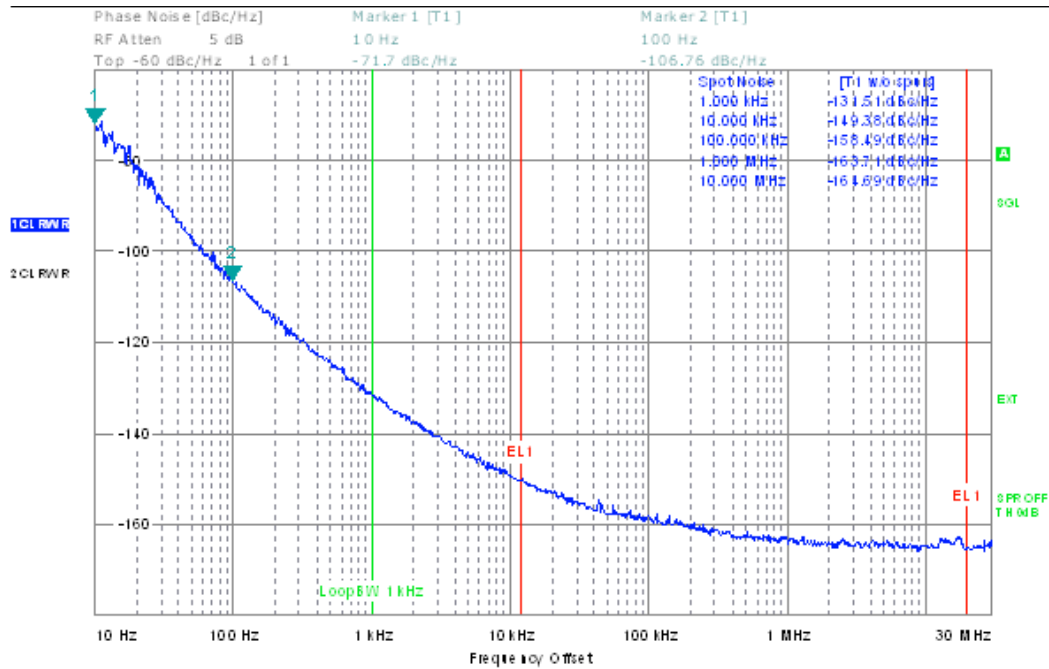

Ordering Information

- V7223T - 050.0M
- V7223T - 080.0M
- V7223T - 098.304M
- V7223T - 100.0M
- V7223T - 122.88M
- V7223T - 125.0M
- V7223T-148.5M
- V7223T-155.52M
- V7223T-156.25M

Package Layout

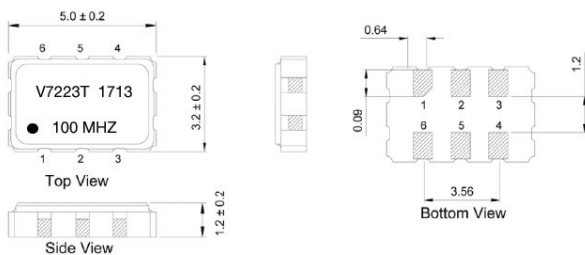

Enable / Disable Function

Enable / Disable Function (Pad 2)	Output
No Connection	Enable
High	Enable
Low	Disable (High Impedance)

Pad Connections

Pin Function

- 1: Control Voltage
- 2: Output Enable (OE)
- 3: Ground
- 4: Output
- 5: N/C
- 6: Vdd

Suggested Pad Layout

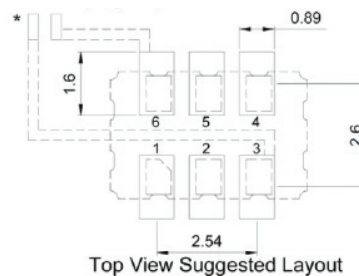

Bulletin	Vx673
Page	2 of 3
Revision	01
Date	12 Oct 2017

Test Circuit

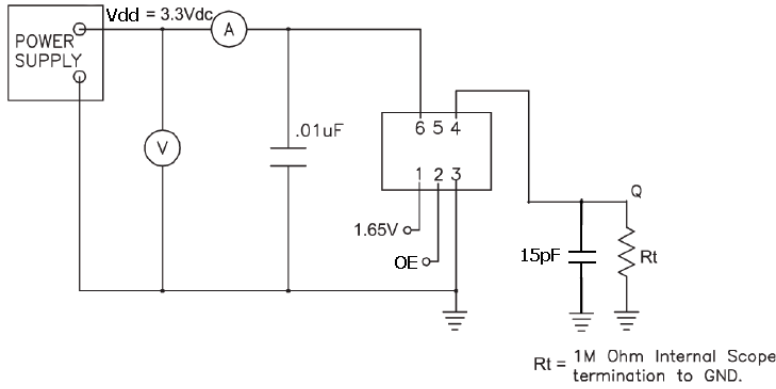

Output Waveform

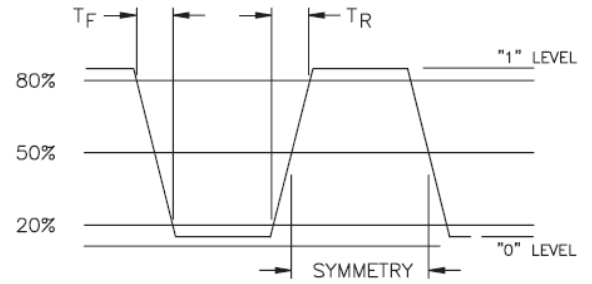

Tape and Reel Dimensions

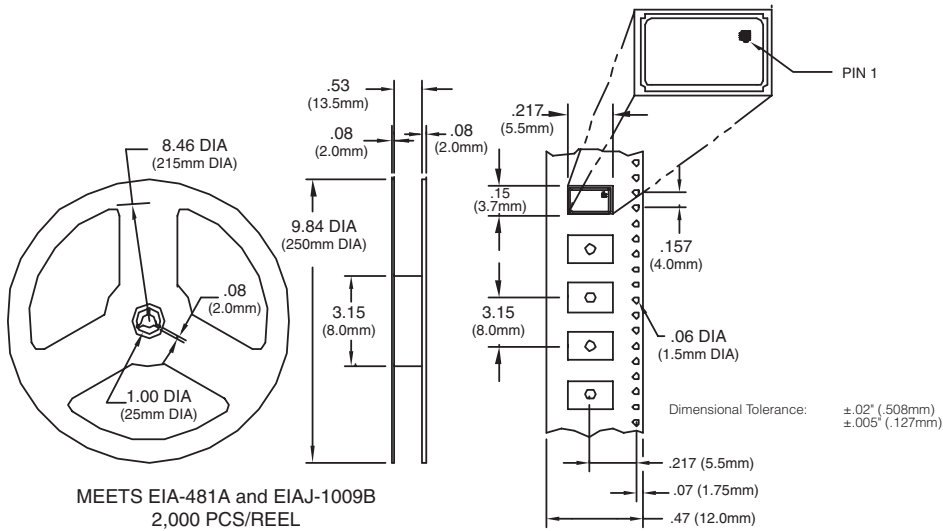

Solder Profile

