

# Automotive Battery Tester

## Users Manual

### INTRODUCTION

This instrument is designed for measuring the voltage of 12V or 24V automotive storage battery. It is very easy to use, just insert it into the cigarette lighter socket, the display will show the voltage of the automotive storage battery, meanwhile the instrument will also give LED indication and bar indication, so you can determine the charge level of the automotive storage battery.

### GENERAL SPECIFICATION

**Display:** LCD

**Application:** measuring 12V or 24V automotive storage battery

**Operation Temperature:** 0°C ~ 40°C, relative humidity < 75%

**Storage Temperature:** -10°C ~ 50°C, relative humidity < 85%

**Size:** 132×48×31mm

**Weight:** about 54g

### INSTRUCTION

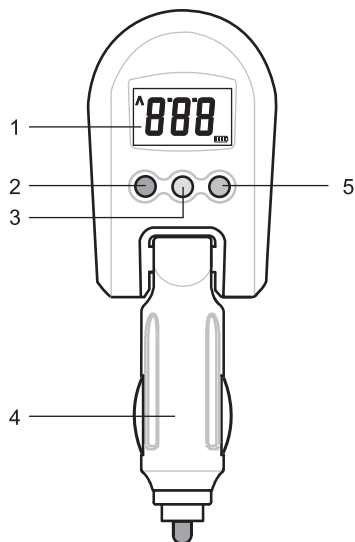

1. LCD Display
2. Red LED
3. Yellow LED
4. Plug
5. Green LED

### LCD Display

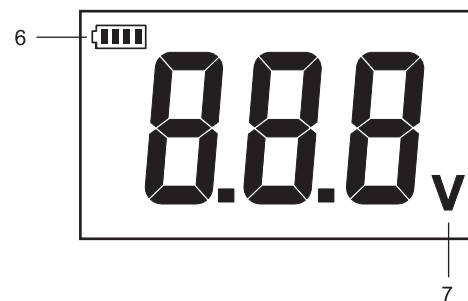

6. Battery Icon  
The number of bars in this icon indicates the charge level analogously.
7. Unit

## OPERATION INSTRUCTION

Insert the plug of the instrument to the cigarette lighter socket, read the reading on the display, and observe the LED indication as well as the bar indication in the battery icon.

By referring the following table, you can determine the charge level of the automotive storage battery.

### Reading and the Corresponding Battery Charge

Reading on the Display		Bar Number	LED Indication	Battery Charge	Analysis
12V Storage Battery	24V Storage Battery				
13.0V ~ 18.0V	26.0V ~ 38.5V	4	Green LED lights.	Full	The storage battery is fully charged.
12.4V ~ 12.9V	24.8V ~ 25.9V	3	Yellow LED lights.	Higher	The charge level is higher.
12.1V ~ 12.3V	24.1V ~ 24.7V	2	Yellow LED and red LED light.	Moderate	The charge level is moderate.
11.7V ~ 12.0V	23.3V ~ 24.0V	1	Red LED lights.	Low	It is necessary to check the battery and the automotive electronic system.
"LLL" appears if the voltage is less than 11.7V.	"LLL" appears if the voltage is between 23.2V and 18.1V.	0	No LED lights.	Too low	

**Note:** If the battery voltage is more than 38.5V, the display will show the overrange indicator "EEE " and you should ask a qualified technician to check the battery and the automotive electronic system.

## NOTE

1. Don't operate the instrument for a long time. If you don't use the instrument, remove it from the cigarette lighter socket.
2. Don't use the instrument to measure a voltage higher than 38.5V.
3. Before use, verify the instrument's operation by measuring a known automotive storage battery.  
Don't operate the instrument if it operates abnormally.
4. Do not operate the instrument around explosive gas, vapor, or dust.

## DECLARATION

1. This manual is subject to change without notice.
2. Our company will not take the other responsibilities for any loss.
3. The content of this manual can not be used as the reason to use the tester for any special application.

### DISPOSAL OF THIS ARTICLE

Dear Customer,  
If you at some point intend to dispose of this article, then please keep in mind that many of its components consist of valuable materials, which can be recycled.  
Please do not discharge it in the garbage bin, but check with your local council for recycling facilities in your area.

