

REVISIONS			
REV	DESCRIPTION	DATE	BY

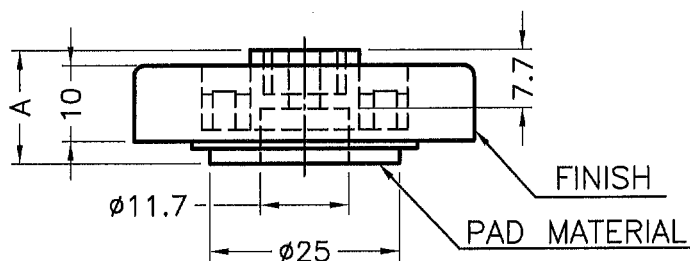
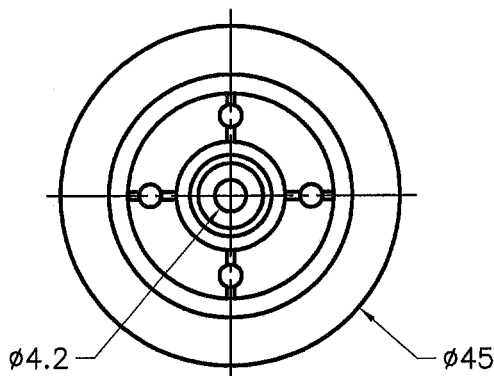

PART NO.	A	FINISH	WASHER
RA-45	15	GOLD PLATED	EVA
RA-45(RUS)	14.0	SILVER PLATED	RUBBER
RA-45(S)	15	SILVER PLATED	EVA
RA-45S(RU)	14.1	SILVER PLATED	RUBBER
RA-45S(RU3)	15.1	SILVER PLATED	RUBBER
RA-45S(I)	14.1	SILVER PLATED	SILICON RUBBER
RA-45B(RU)	14.1	BLACK PLATED	RUBBER

康揚符合歐盟ROHS規範 (K. Y. Accord EU RoHS Compliant)

★鉛Pb	<1000PPM
★鎘Cd	< 100PPM
★汞Hg	<1000PPM
★六價鉻Cr6+	<1000PPM
★多溴聯苯類PBBs	<1000PPM
★多溴聯苯醚類PBDEs	<1000PPM

PART NUMBER SEE ABOVE				DRAWING NUMBER RA-45S		TITLE PLASTIC FOOT					
				SIZE A4		SCALE 1:1		MATERIAL A.B.S		DATE 1997.12.30	
				UNIT mm		REV B		METAL MATERIAL AL		DRAWN JASON	
				UNLESS OTHERWISE SPECIFIED TOLERANCE ±0.4		BODY COLOR BLACK		CHECK 		APPROVED <i>Rang</i>	