

Data Sheet

ROM-2235P-HD-R

PUI Audio's all-new **HD Series** microphones use premium-grade FETs and diaphragms for high sensitivity and superior signal-to-noise ratio. Each microphone features GSM buzz-blocking capacitors. Upgrade the ECM microphone that you use today with a PUI Audio **HD Series** microphone.

The 5.8mm diameter **ROM-2235P-HD-R** is designed for extreme fidelity in a compact housing with thru-hole pins and true 20 Hz to 20 kHz performance.

Features:

- 5.8mm diameter
- 2.7mm height
- -35 dB sensitivity
- 68 dB signal-to-noise ratio
- True 20 Hz to 20 kHz performance

Specifications

Parameters	Values	Units
Sensitivity (1 kHz @ 50cm) 0 dB=1V/Pa	-35 ±3	dB
Rated Voltage	3	VDC
Output Impedance (@ 1 kHz)	2.2	kΩ
Current consumption (3VS with 2.2 kΩ RL)	500	μA
Signal-to-Noise Ratio (1kHz, 94 dB input, A-weighted)	68	dB
Decreasing Voltage (3VS to 2VS)	-3	dB
Frequency Range	20 ~ 20,000	Hz
Operating Voltage Range	1 ~ 10	VDC
Maximum SPL Input (THD<3%)	110	dB
Directivity	Omni-directional	-

Specifications (continued)

Operating Temperature	-20 ~ +70	°C
Storage Temperature	-40 ~ +85	°C
Weight	<0.5	Grams

Measurement Method (in Anechoic Chamber)

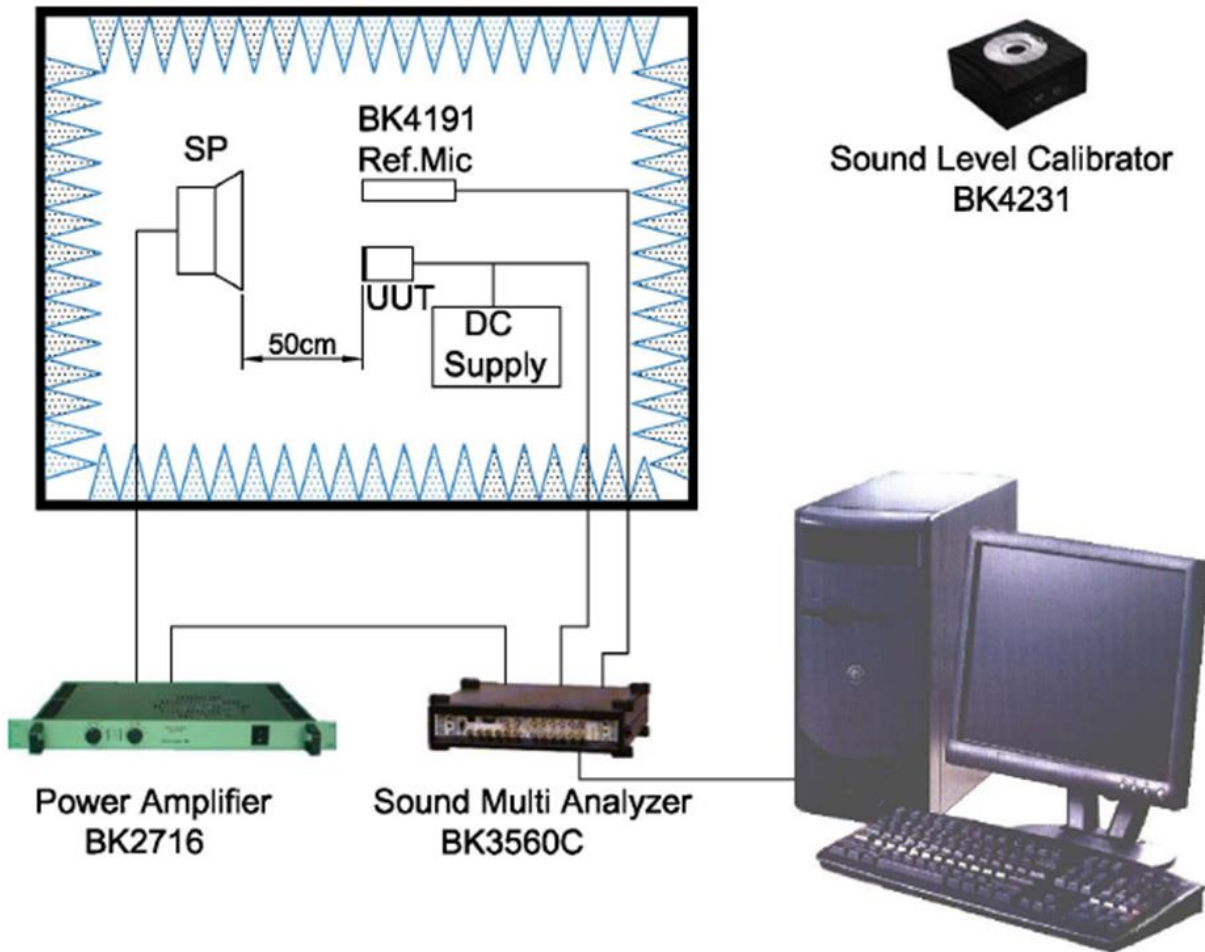

Typical Frequency Response (measured at 50cm with 3V input and 94 dB source)

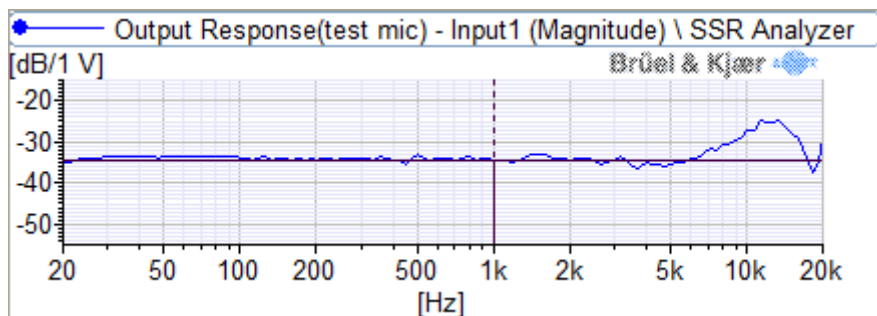

Reliability Testing

Type of Test	Test Specifications
High Temperature Test	200 hours at +70°C ± 3°C followed by two hours in normal room temperature
Low Temperature Test	200 hours at -25°C ± 3°C followed by two hours in normal room temperature
Humidity Test	200 hours at +40°C ± 3°C with relative humidity at 90% to 95% followed by 2 hours in normal room temperature
Temperature Cycle Testing	30 minutes at -25°C, 10 minutes at 20°C, 30 minutes at +70°C, 10 minutes at 20°C for five cycles, followed by 2 hours in normal room temperature
Vibration Test	10 to 55 Hz for 1 minute with 1.52mm distance, followed by a two hour 3 axis test in packaging
Drop Test	Drop microphones in packaging onto concrete floor from 1 meter height in each of 3 axis
ESD Test (according to IEC 6100)	<ol style="list-style-type: none"> Contact discharge - Discharge 6000 VDC from capacitor into microphone output through 330Ω resistor ten times. Air discharge - Discharge 8000 VDC into sound hole of the microphone ten times.

After each test, the speaker's SPL shall be ±3 dB of the original SPL

Dimensions

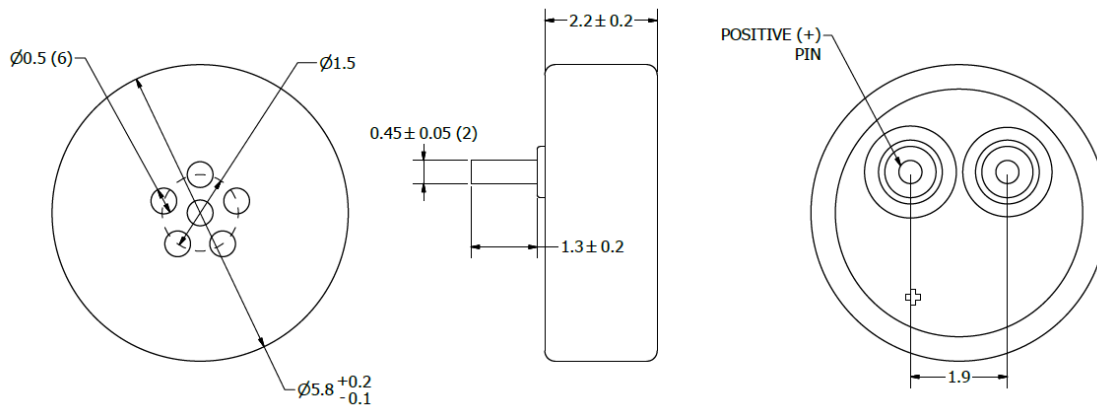

Recommended Drive Circuit

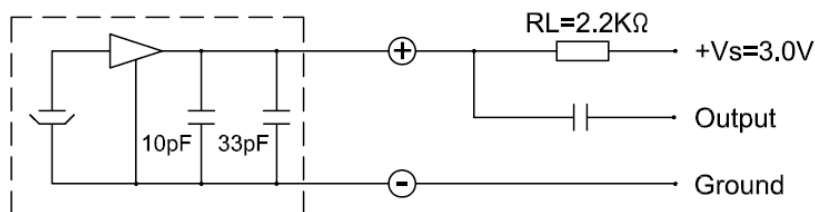

Microphone Handling Precautions

High temperature and/or static electricity may damage microphones. To ensure careful handling, we suggest following these precautions:

- Ensure the power rating of the soldering iron is below 90 watts
- The temperature of the soldering iron must be limited to 360°C ±10°C (380°F ±50°F)
- Soldering duration for each terminal shall be at or under 2 seconds
- If practical, use a metal fixture to hold the microphone in-place and to act as a heatsink. A fixture should have appropriate diameter holes drilled through the entire fixture to prevent pressure from being placed on the diaphragm (as below)

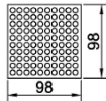
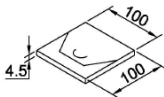
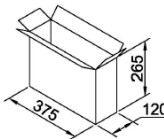
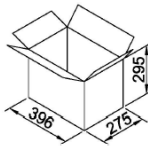

Packaging

	Drawing	Qty (pcs.)	Size(mm) L×W×H	Material
Packing		100	98×98×4.1	Paper
Inner Package		100	100×100×4.5	Paper
Middle Package		15000 (150×100)	375×120×265	Paper
Outer Package		30000 (2×15000)	396×275×295	Paper

Specifications Revisions

Revision	Description	Date
-	Released from Engineering	6/6/2017

Note:

1. Unless otherwise specified:
 - A. All dimensions are in millimeters.
 - B. Default tolerances are $\pm 0.5\text{mm}$ and angles are $\pm 3^\circ$.
2. Specifications subject to change or withdrawal without notice.
3. This part is RoHS 2011/65/EU Compliant.