

VARIANTS	
PART No.	HOLE DETAILS
CP30212MB	HOLE Ø3.50 x CSK 82° x Ø5.85
CP30212M3B	M3 HOLES

PANEL CUTOUT
MAXIMUM PANEL
THICKNESS 3mm

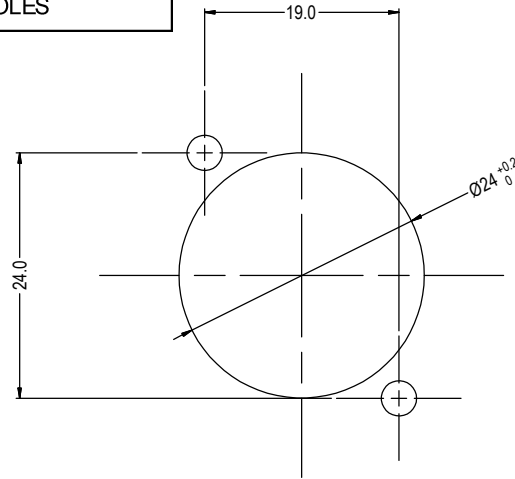
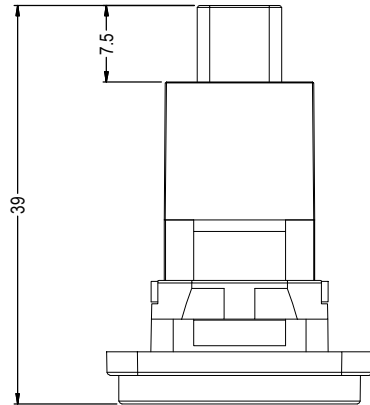

ISS.	AMEND	DATE
1	ISSED	07/02/17
2	ADD M3 VARIANT	01/06/18

NOTES:

Receptacle to Plug connection:

A1 to A1, A2 to A2, A3 to A3 etc..
B1 to B1, B2 to B2, B3 to B3 etc..

Materials:

Frame: Diecast, Black
Insert: ABS - UL94 HB

USB-C Specification:

Maximum Rated Current - 3A
Maximum Working Voltage - 30V
Withstanding Voltage - 100V for 1 minute.
Contact Resistance - 40 Milli-ohms Max.
Insulation Resistance - 100 Mega-ohms Min.
Insulator Flammability Rating - UL-94V0
Insertion Life - 10,000 Cycles.

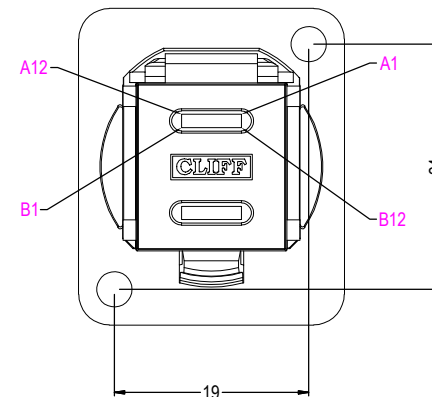
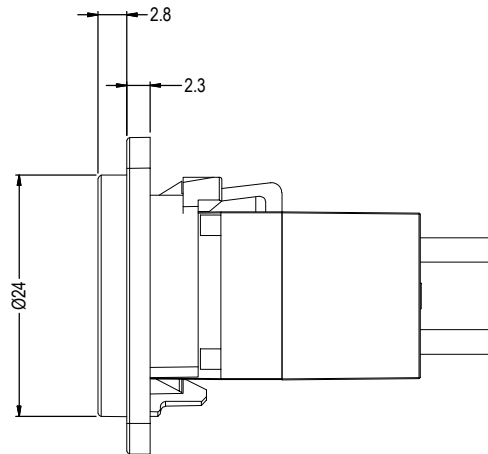
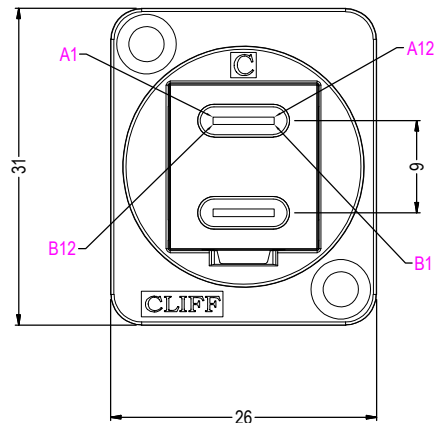

Cliff Electronic Components Ltd.

76 Holmethorpe Avenue, Holmethorpe Industrial Estate,
Redhill, Surrey, RH1 2PF, England, UK
Tel: 01737-771375 Fax: 01737-766012 Website: www.cliffuk.co.uk

THE CONTENTS OF THIS DOCUMENT MUST NOT BE COPIED OR DISCLOSED
TO A 3rd PARTY WITHOUT WRITTEN PERMISSION OF CLIFF UK. © 2017

DIMENSIONS IN MILLIMETERS UNLESS OTHERWISE STATED. WORK TO DIMENSIONS. REMOVE ALL BURRS. IF IN DOUBT ASK.

MATERIAL: SEE NOTES

FINISH: CLEAN

DRAWN: D.P.J.

APPROVED: D.P.J.

3rd ANGLE PROJECTION:

TITLE: FT BLACK METAL DUAL USB-C (F-M)

DRWG. No. CP30212MB

FORM: A4DRWGf

RoHS
COMPLIANT

TOLERANCE
NO DEC. PLACE ±
1 DEC. PLACE ±
2 DEC. PLACE ±
HOLE Ø ±
ANGLES ±
UNLESS OTHERWISE STATED

DO NOT SCALE