

LOC	DIST	REVISIONS						
		P	LTR	DESCRIPTION	ECN	DATE	DWN	APVD
J			C	REDRAWN WITH CHANGE	FJ00-1066-98	4 JUN '98	<i>Dr. S. M.</i>	
			C1	REVISED	ECR-05-007890	29 JUL 05	Y.Y	N.Y
			D	REVISED	ECR-09-008697	16 APR '09	Y.Y	N.Y

表1 TABLE 1

トレードマーク TRADE MARK	生産場所 MANUFACTURING LOCATION
AMP	シンガポール SINGAPORE
Tyco	中国 CHINA

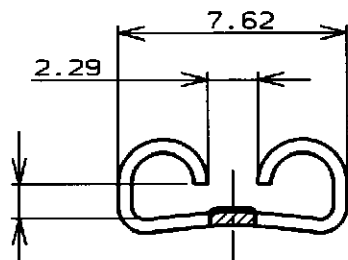
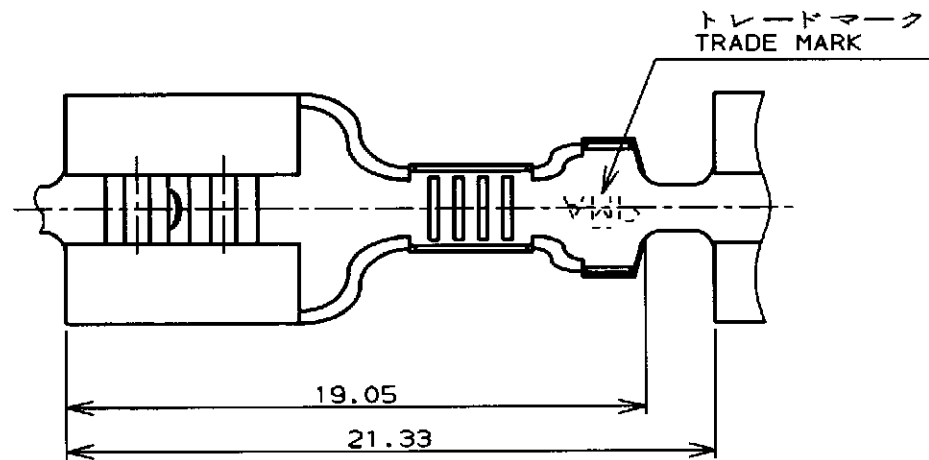

この寸法は嵌合力によって管理する。  
BE CONTROLLED BY MATING FORCE

矢視 A-A  
VIEW

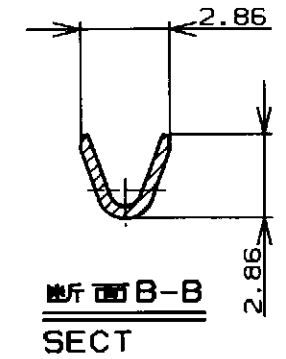
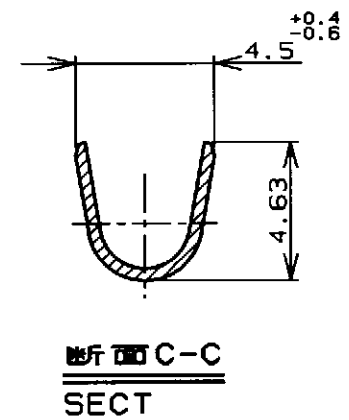
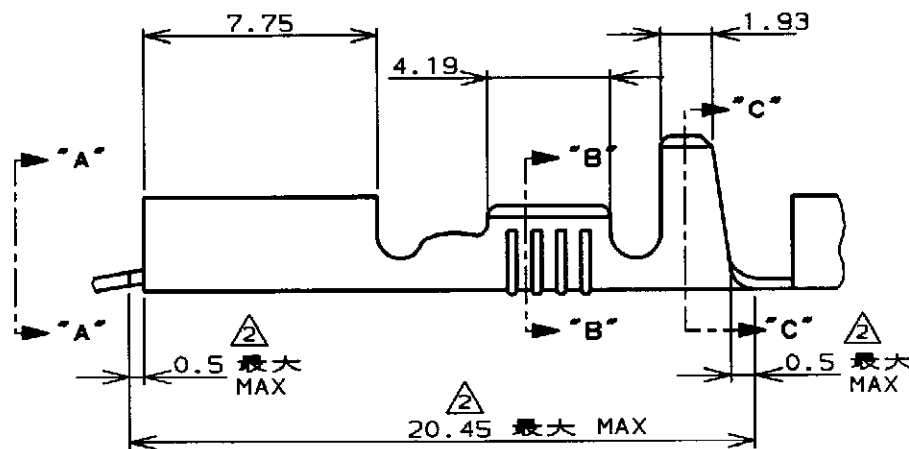

- 注:
1. 嵌合するフォストンタブの詳細については#CP63-048Jの図面を参照の事
  - △ LP型番の時のカット位置を示す
  - △ ストレス除去処理  
処理法により外観が変わります。  
不活性ガス加熱方式 . . . 無光沢  
大気加熱方式 . . . . . 光沢

- 表1参照  
NOTES:
1. SEE DWG CP63-048J FOR THE DETAIL OF MATING TAB
  - △ INDICATE CUT DIMENSION FOR LOOSE PIECE PART
  - △ STRESS RELIEVING  
FINISH IS SUBJECT TO CHANGE BY THE TYPE OF STRESS RELIEVING PROCESS  
INERT GAS FURNAS . . . . . MATTE  
ATMOSPHERIC FURNAS FOLLOWED BY ACID PICKLE . . . BRIGHT
  - △ SEE TABLE 1

170183-2	170187-2	BRASS 0.4 THK 黄銅 板厚0.4	TIN PLT 錫めつき	108-5178
170183-1	170187-1	BRASS 0.4 THK 黄銅 板厚0.4	—△—	108-5006
型番 (P/N)	LP型番 (ワイヤパネルが アプライフォーム)	MATERIAL 材質	FINISH 仕上	PRODUCT SPEC 製品規格番号

THIS DRAWING IS A CONTROLLED DOCUMENT FOR AMP INCORPORATED. IT IS SUBJECT TO CHANGE AND THE CONTROLLING ENGINEERING ORGANIZATION SHOULD BE CONTACTED FOR THE LATEST REVISION.		DWN <i>Dr. S. M.</i> 7 JUN '98 CHK <i>M. S.</i> 4 JUN '98 APVD <i>Si Kubonoh</i> 4 JUN '98		<b>Tyco Electronics</b> Tyco Electronics Corporation Kawasaki, Japan	
DIMENSIONS, 単位・純 mm		TOLERANCES UNLESS OTHERWISE SPECIFIED 一般公差 10% : ±0.2 30% : ±0.25 100% : ±0.3 ANGLE : ±0.3° ±0.4		NAME 名称 ("250" SERIES FASTON RECEPTACLE) "250" シリーズファストンリセプタクル	
		MATERIAL 材料 表参照 (SEE TABLE)		FINISH 仕上 表参照 (SEE TABLE)	
PRODUCT SPEC 製品規格 108-5006		APPLICATION SPEC 取付適用規格 114-5084		WIRE RANGE 被合電線断面積 0.30~0.89mm <sup>2</sup> (AWG22-18)	
INSULATION DIA 被覆外径 2.29-33mm (.090-.130IN)		WEIGHT —//—		SIZE CAGE CODE DRAWING NO 番号 A3 00779 C-170183	
CUSTOMER DRAWING		SCALE 尺度 4-1		SHEET 1 OF 1 REV D	