

Part No. 1F053LVGBK06CA01

§ Standard 5mm diameter package.

Characters

§ Supply Voltage Range ± 4.5 V DC

§ Low Standby Current $5\mu\text{A}$

§ Power On—On Mode

§ Input current : 90 mA

§ Power Consumption : 0.405 W

ITEM		MATERIALS
Resin(Mold)		Epoxy
Lens Color Code	C	Water Transpatent
	M	White Diffused
Lead Frame		Ag Plating Iron Alloy
Dice	R	AlInGaP
	G	InGaN
	B	InGaN

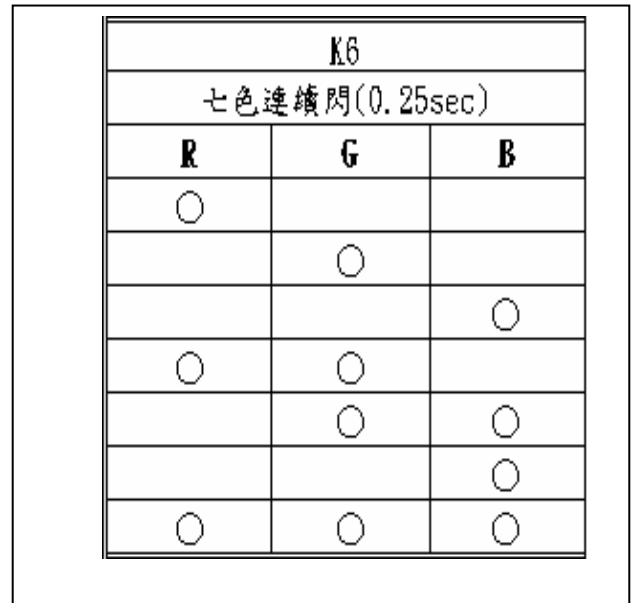

Absolute Maximum Ratings (Ta=25°C)

Item	Symbol	Value			Unit
		R	G	B	
Power Dissipation	1%				
DC Forward Current	*I				N "
Pulsed Forward Current	*I1		*		N
Reverse Voltage	73				7
Operating Temperature	5PQS				
Storage Temperature	5TIF				
Soldering Temperature	5TEM		GP		S T F D

* Duty 1/10 Pulse Width 0.1ms † At the position of 4mm from the bottom

Electrical-Optical Characteristics (Ta=25°C)

Vdd=4.5V, Ta=25 , Unless otherwise specified						
Characteristics	Symbol	Min	Typ	Max	Unit	
Dominant Wavelength	R	λd	620	630	0 N	
	G	λd	522	537	0 N	
	B	λd	461	473	0 N	
Forward voltage	R	VF	1.7	1.9	2.4	7
	G	VF	2.8	3.2	3.8	7
	B	VF	2.8	3.2	3.8	7

Notes:

§ Lead spacing is measured where the leads emerge from the package.

§ \$ BV UJP O JO & 4 % 4UBUJD & MFD U UI F -&% * U JT SFD PNNFOEFE BOUJ FMFDUS PT UBUJD HMP WF XI F E FWJD FT FR VUBQ NJD @SUZ NB/TUE C HSPVOEFE

-Specifications are subject to change without notice.

Outline Dimensions

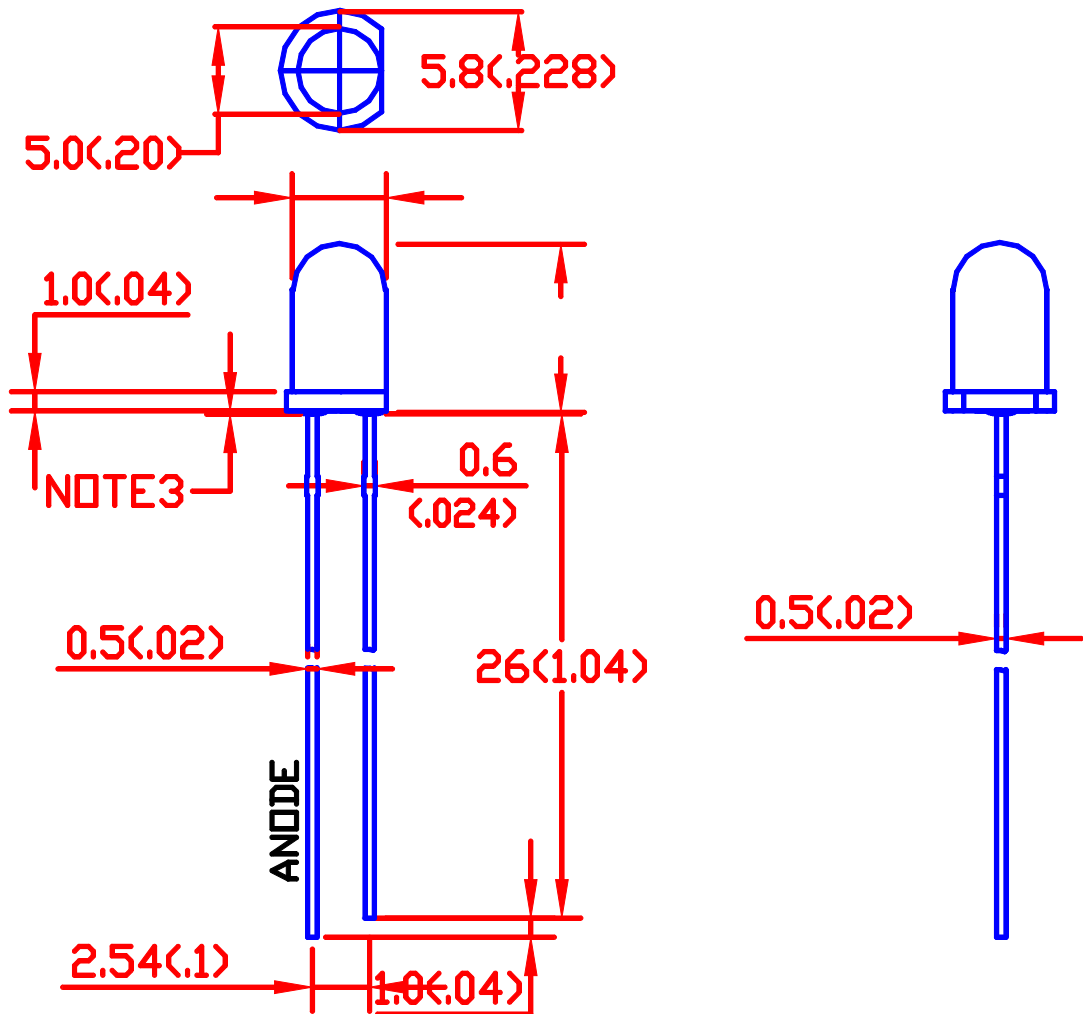

- § All dimensions are in millimeters (inches) .
- § Tolerance is ± 0.25 (.010) mm unless otherwise noted.
- § **NOTE 3** Protruded resin under flange is 1.0 mm (.04) max.

PCB Multi-Color LED

Usage and Handling Instructions

Dear valued clients:

Thank you for choose our LED products. LEDs are delicate semiconductor product that should be handle according to the below instructions.

A. Storage:

LEDs should be stored in an environment with ambient temperature of 23 ± 5 and relative humidity of 40 ~ 70 %.

LEDs should be used within three months of being taken out of their original packages to avoid lead frame rusting.

B. Cleaning:

1. Do not use any unidentified chemical to clean LEDs, it could damage or crack the LED epoxy surface. If necessary, soak LED in alcohol for a time not exceeding one minute in normal temperature.

C. Lead Frames Shaping & Trimming

1. The shaping should be done underneath the wedge point. No pressure should be exerted to the epoxy shell of the LED during shaping.
2. Bending of the leads should be done at a point at least 4 mm from the base of the LED lens.

Shaping of the leads should be done before soldering.

Lead trimming should only be done at normal temperature.

D. Soldering

1. When soldering, the soldering iron needs to be at least 2mm away from the epoxy edge. After soldering, allow at least 3 minutes for LEDs to cool back to normal temperature. Do not apply any pressure to the epoxy encapsulation or the lead frame during the soldering process.

-
-
2. When reflow soldering or wave soldering, please solder once for less than 5 seconds at a maximum temperature of 260 C. During the soldering process, if the temperature or timing is not controlled within limits, it would cause the epoxy to deform or cause the die or wires within the LED to be damaged.
 3. When using soldering iron, please solder once for less than 5 seconds at a maximum temperature of 300 C. When soldering a row of LED on a PCB, please do not solder both leads of a LED in sequence. (Solder all the positive lead first, then all the negative leads)
 4. Do not dip the epoxy encapsulation part of LED into any soldering paste liquid.
 5. After soldering, do not adjust the location of the LED anymore.
When attaching electronic parts to a PCB with LEDs, the curing time for the whole PCB should be less than 60 seconds, at less than a temperature of 120 C.

E. Installation

1. During the installation process, do not apply any pressure to the leads.
2. Please make sure the installation holes on the PCB matches the leads of the LED.

F. ESD (Electrostatic Discharge)

1. LED is very sensitive to ESD; please make sure during the whole usage and installation process, that no ESD exist to affect the LED. Excessive ESD could damage the LED chip and result in performance degradation.
2. LED can also be damaged by electrical surge, please make sure any driving electrical circuits are equipped with surge protection.
3. During the installation process, please make sure all the equipment and personnel are grounded properly. Make use ESD protection equipment such as anti-static gloves, anti-static wrist bands, anti-static mats, anti-static clothes, anti-static shoes, and anti-static containers.
4. When LED come into contact with low electrical resistance metallic surfaces, the ESD could damage the LED due to sudden discharge of ESD. Please make sure all surfaces that will be in contact with LED are covered

with anti-static mats (Surface electrical resistance of $10^6 \sim 10^8 \Omega/\text{sq}$). LED should be placed in anti-static containers and anti-static bags.

5. All soldering irons should be grounded and production environment should make use of ion-blowers.

G. Recommended Usage Guidelines

Circuit connections I

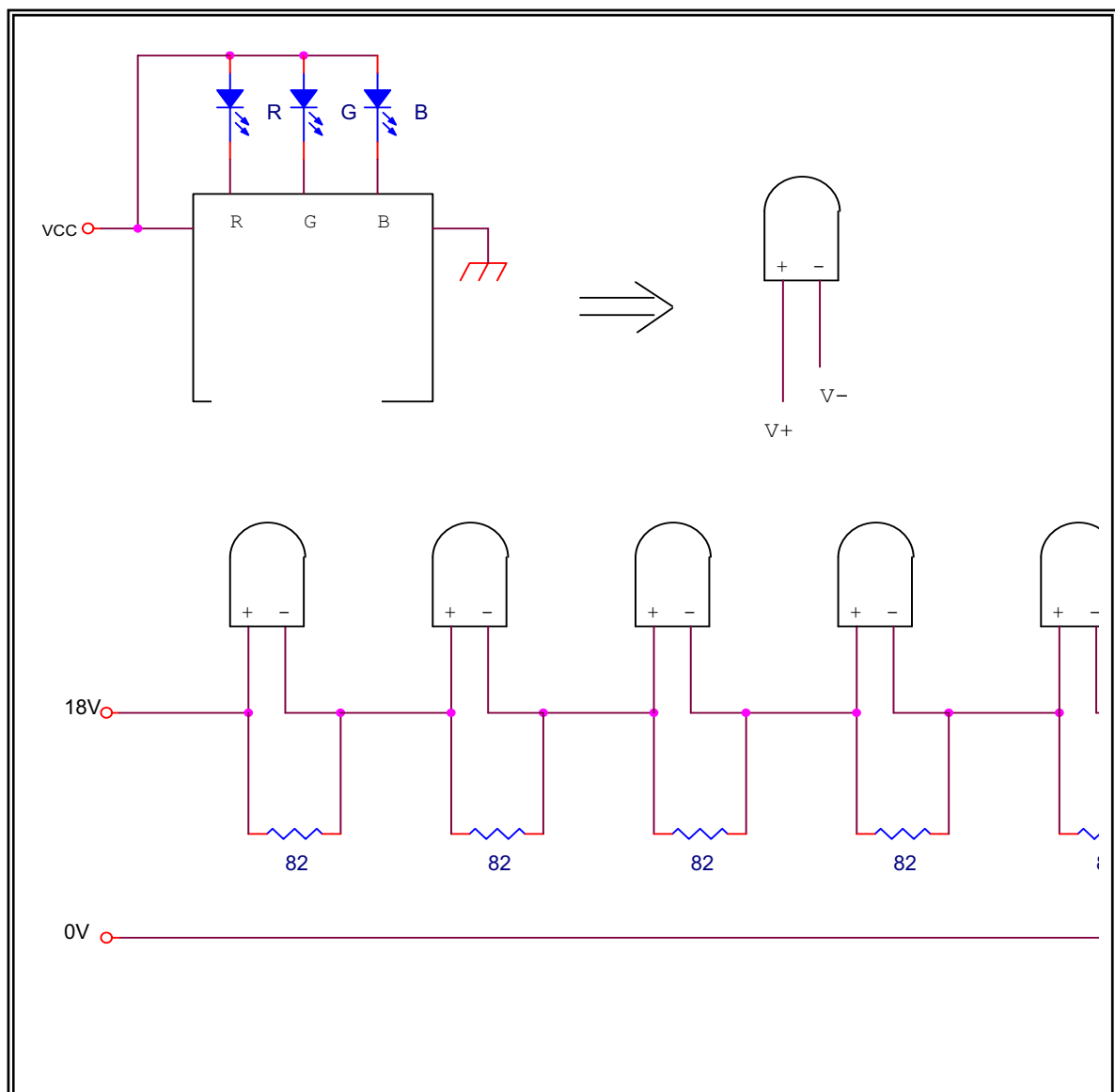

Circuit connections II

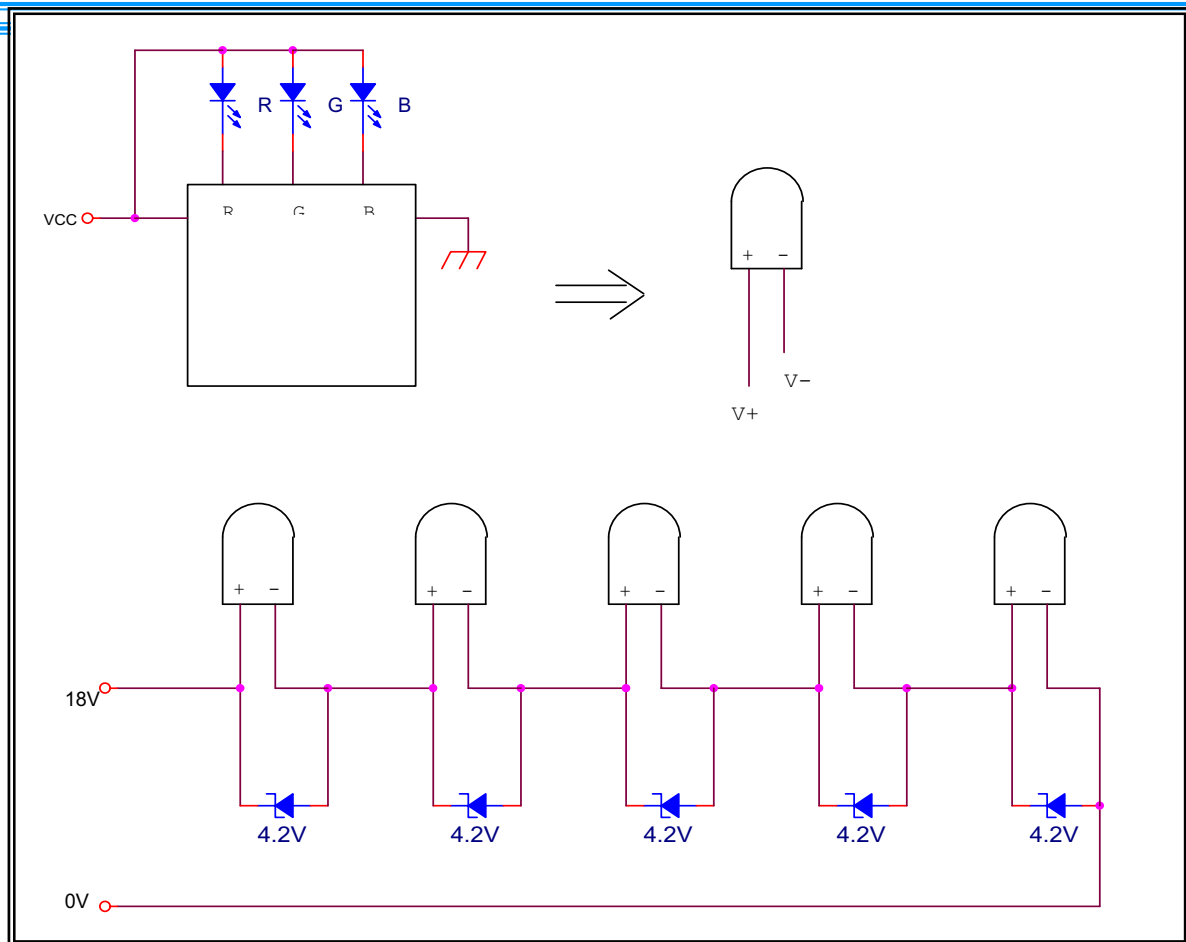

1. Sudden pulse will damage the internal connection of the LED. Therefore the circuit must be designed carefully to avoid damaging the LED when it is switched on and off.
2. The diameter of the dip holes on PCB should be at least 0.8mm. The distance between the centers of the two dip holes should be within $\pm 0.02\text{mm}$ of the LED lead pitch (standard LED lead pitch is 2.54mm). For special LED lead pitch specifications, the distance should be adjusted accordingly.
3. The initiative forward voltage should be $4.5 \pm 0.1\text{V}$. If not, the LED can't reach its normal luminous intensity or even fail because of overheat. Users should follow this handling instruction to avoid damage.

H. Safety

1. Please comply with government electrical safety code while using the LEDs.
2. Do not look directly into a lit LED; it could damage the eyes after only a few seconds.