

Montageausschnitt/
panel cut out
1:1

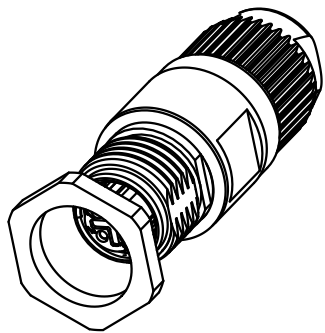
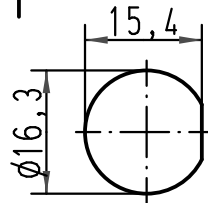

All Dimensions in mm Original Size DIN A 4		Techn. Character.			Nicht tolerierte Maß/Free size tolerances	
			Dat.	Name	Maßstab/Scale 2:1	Wanddurchführung M12 IDC Panel feed through M12 IDC 4polig Buchse D-kodiert geschirmt 4poles female D-coded shielded
		Detail.	29.08.07	Ho		
		Insp.		SUN		
		Stand.				
413163		HARTING Electric GmbH & Co. KG D-32339 Espelkamp				TB 21 03 381 2425 Sub.
Mod.	Dat.	Name		Blatt/page		