



Coupling connectors

Sicma

4 way mini-sealed coupling housings for 1.5 mm terminals

Features

- 4 position housings
- 3.33 mm pitch
- Reduced size sealed housings
- Female part can be used as an aggregate housing
- Circumferencial interface seal on female housing
- Rear sealing ensured by a pre-mounted mat-seal
- Pre-assembled front grids support blade terminal guiding and mating
- Terminal position assurance (T.P.A.)
- CPA optional available
- GO-NO-GO housing locking principle
- Mechanical polarization
- Several colour codings available



Performance characteristics

- Temperature range: from -40°C to +125°C
- Contact retention force: > 100 N
- Contact insertion force: < 12 N
- Connector mating force: < 60 N
- Sealing protection: IP 68
- Acceptable wire range: 0.5 mm² to 2 mm² for 1.5 mm

Construction

- Housing material: PBT
- Interface seal: Silicone
- Rear mat-seal: Silicone

Tooling

- T.P.A. removal tool: 210S040
- Terminal removal tool
 - Female terminal: 2115015
 - Male terminal: 2115016
- Cavity plug: 210A015019

Connector compatibility

- Usable terminals:
 - Sicma-2 1.5 mm female terminals
 - Sicma-2 1.5 mm male terminals
 - Sicma-3 1.5 mm female terminals
 - Sicma-3 1.5 mm male terminals

Part number	No. of position	Terminal size	Type	Colour	Full schroud
211 PC042S0049	4	1.5 mm	Female	Black	N
211 PC042S1049	4	1.5 mm	Female	Brown	N
211 PC042S4049	4	1.5 mm	Female	Yellow	N
211 PC042S5049	4	1.5 mm	Female	Green	N
211 PC042S6049	4	1.5 mm	Female	Blue	N
211 PC042S8049	4	1.5 mm	Female	Grey	N
211 PL042S0049	4	1.5 mm	Male	Black	N
211 PL042S1049	4	1.5 mm	Male	Brown	N
211 PL042S4049	4	1.5 mm	Male	Yellow	N
211 PL042S5049	4	1.5 mm	Male	Green	N
211 PL042S6049	4	1.5 mm	Male	Blue	N
211 PL042S8049	4	1.5 mm	Male	Grey	N



Coupling connectors

Sicma

4 way mini-sealed coupling housings for 1.5 mm terminals

Dimensional characteristics

Notes :

Female housing - half shroud

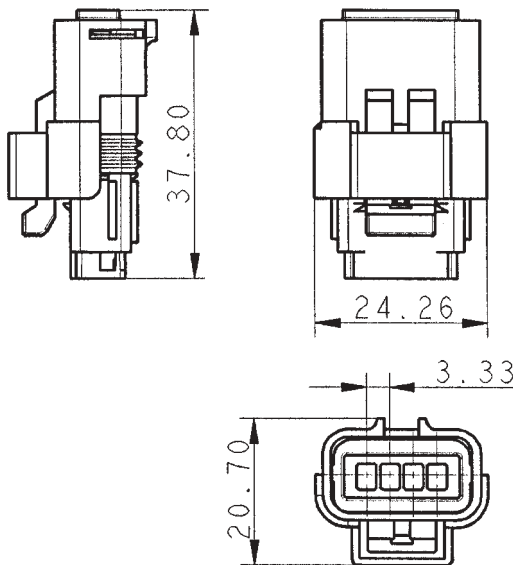

Male housing

