

NO	件號 PAT. NO	名稱 NAME	材質 MATL	件數 SHT	處理 TREAT	備註 REMARK	NO	件號 PAT. NO	名稱 NAME	材質 MATL	件數 SHT	處理 TREAT	備註 REMARK
1	B-230ZN	下固定體 BODY	Zn ALLOY	1	M-Ni	噴砂	8	B-227FN-R	上固定體 BODY	SPCC	1	M-Ni	———
2	H-079RX	線 管 PIPE	RUBBER	1	GRAY	———	9	C-078ZN	固定鍵 BUTTON	Zn ALLOY	1	M-Ni	———
3	H-078PX	套 管 PIPE	SILICON	1	GRAY	———	10	D-046ZN	半月邊 CLAMP	ZN ALLOY	1	M-Ni	噴砂
4	I-143PX	絕緣體 INSULATOR	TPR	1	GRAY	———	11	M-054FN-R	半月邊螺絲 SCREW	STEEL	2	M-Ni	———
5	K-076BS-R	導 梢 CONTACT	COPPER ALLOY	3	M-Ag	———	12	M-053FN-R	側螺絲 SCREW	STEEL	1	M-Ni	———
6	Q-084BS-R	彈 片 SPRING WASHER	BeCu	3	M-Ag	———	13	O-067FZ-R	彈簧華司 SPRING WASHER	SPCC	1	M-Zn	———
7	Q-112SX	彈 片 SPRING WASHER	SUS	1	———	———							

智慧財產權 請勿抄襲盜用

APEX CONNECTOR PROPRIETARY

本產品符合 RoHS 指令



No.	ELECTRICAL SPECIFICATIONS	
1	Rated current/voltage(AC)	10A/133V
2	Insulation resistance	5000MΩ min. at 500VDC
3	Contact resistance (mΩ MAX.) at DC1A	10

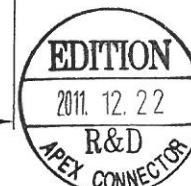
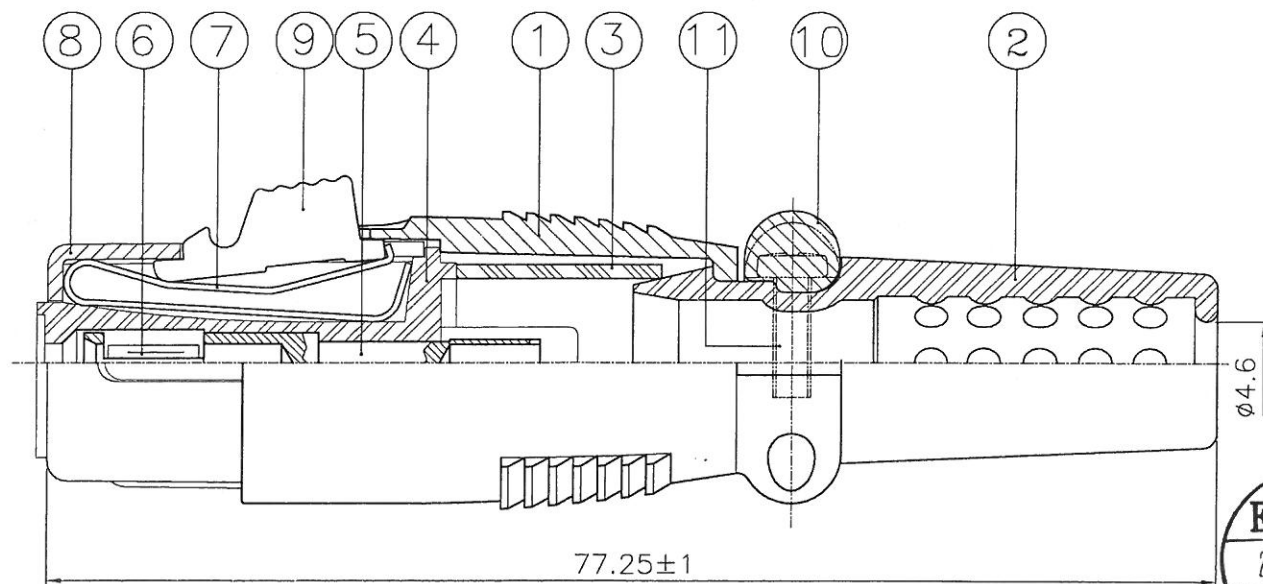
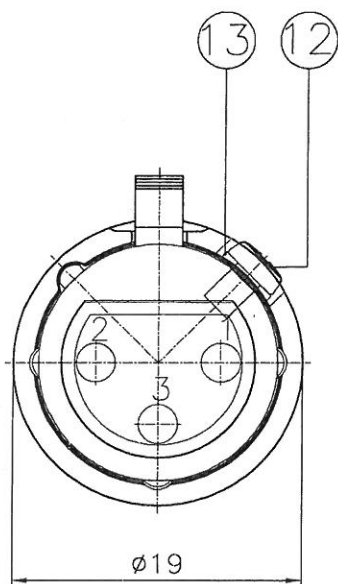

ISO-9001:2008 CERTIFIED MANUFACTURER



鋁鋼精密科技股份有限公司  
APEX PRECISION TECHNOLOGY CORP.



NO. 變更說明 CORRECTION

機種 MODEL	名稱 NAME	DATE	UNIT	DESIGNER	CHECKED	APPROVE
MA-3F-ZNSR-R	3PIN MIC CONNECTOR	2011.12.16	mm	開發部 2011/12/16 Yu	cheng 2011.12.20	核 2011.12.20
		TOLERANCE	SCALE			
		±0.2	2 X			