



ENGLISH

Datasheet

DC Axial Fan

RS Stock number 541-5110



Frame and Impeller
PBT, UL94V-0 Thermoplastic

Available Options
Tachometer
Locked Rotor Alarm

Finger Guard: G109-15A, G109-15AB, G109-3
Plastic Guard: G120P
Wire Mesh Guard: WMG120M
Filter Kit: GRM120-30, GRM120-45

Specification

MOTOR

Brushless DC, polarity protected, locked rotor protected (current limited), auto restart

INSULATION RESISTANCE

Min. 10 M Ohm at 500VDC

LIFE EXPECTANCY (L10)

Ball Bearing 60,000 Hours

Operating Temperature

-10C ~ +70C

Safety Approvals

UL/CUL, TUV, CE

Dimensions: (mm)

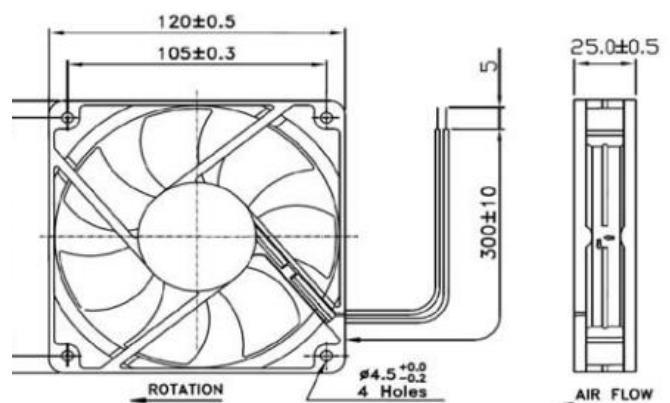

*Drawing for Dimensional Reference Only