

NO	DESCRIPTION	DATE
△	BACKGROUND FORMAT UPDATED	06.06.02'
△	MODIFICATION PARTS ②③⑥⑦ DEL EPOXY SOLDER → SILVER BRAZING BACKGROUND FORMAT UPDATED	08.17.09'
△	WORKING VOLTAGE → VOLTAGE RATING DEL. PROOF VOLTAGE	11.19.13'

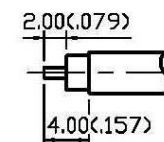
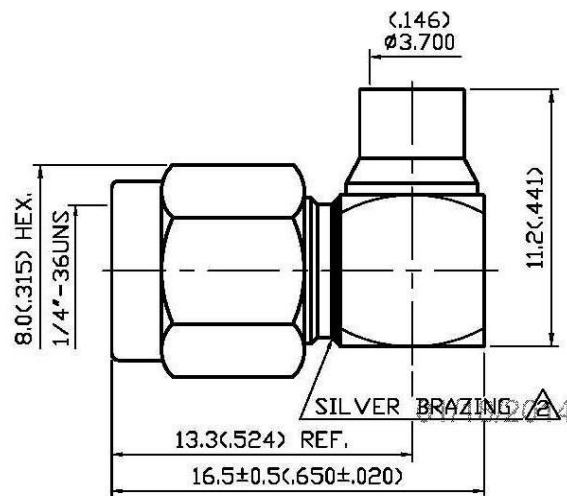

STRIPPING DIMENSION
SCALE 2:1

1.0 ELECTRICAL

- 1.1 FREQUENCY RANGE: DC-12.4 GHz
- 1.2 NOMINAL IMPEDANCE: 50 OHM
- 1.3 VOLTAGE RATING: 500 VOLTS MAX. △
- 1.4 VSWR: 1.23 MAX.

2.0 MATERIALS

- 2.1 BODIES: BRASS PER JIS-C3604
- 2.2 CENTER CONTACT: BRASS PER JIS-C3604
- 2.3 INSULATION: TEFLON PER ASTM D1457 AND ASTM D1710

3.0 FINISHES AND OTHERS

- 3.1 SEE BELOW TABLE FOR DETAILS.

4.0 MECHANICAL

- 4.1 INTERFACE IN ACCORDANCE WITH: MIL-STD-348A
- 4.2 FOR USE WITH RG402U OR SIMILAR STYLE CABLE
- 4.3 CABLE ATTACHMENT: OUTER: SOLDER, INNER: SOLDER
- 4.4 RECOMMENDED COUPLING TORQUE: 3 TO 5 in-lbs

5.0 ENVIRONMENTAL

- 5.1 OPERATING TEMPERATURE RANGE: -65° C TO +165° C

NO	DESCRIPTION	MATERIAL	Q'TY	FINISH
8	CAP	BRASS	1	GOLD 3 μ" MIN.
7	CHASSIS	BRASS	1	GOLD 3 μ" MIN.
6	BODY	BRASS	1	GOLD 3 μ" MIN.
5	WASHER	STAINLESS STEEL	1	NONE
4	GASKET	SILICONE	1	RED
3	INSULATION	TEFLON	1	NONE
2	CENTER CONTACT	BRASS	1	GOLD 50 μ" MIN.
1	SHELL	BRASS	1	GOLD 3 μ" MIN.

APPROVED

by _____ DATE: _____



DESCRIPTION		SMA RIGHT ANGLE PLUG SOLDER	
製圖	DRAWN Yoko	TOLERANCE .X ±0.2	品名 19-02-12 T.G.G RG402
檢圖	CHECK Angela	.XX ±0.1	DATE 02.16.00'
認定	APPROVAL Angela	.XXX ±0.05	REV. A-3
	ANGLE ±5°	比例 4:1	DATE 02.16.00'
			版次 A-3
			UNIT mm(in)
			SCALE
			DWG.NO. 19-0052
			ROHS COMPLIANT (<50Ω)