

SPECIFICATIONS

- CONTACT RATING:** Dependent upon contact material.
- MECHANICAL LIFE:** 30,000 make-and-break cycles.
- CONTACT RESISTANCE:** 20mΩ max. initial @ 2-4VDC
100mA for both silver and gold plated contacts.
- INSULATION RESISTANCE:** 1,000MΩ min.
- DIELECTRIC STRENGTH:** 1,000 V RMS@sea level.
- OPERATING TEMPERATURE:** -30°C to 85°C.

MATERIALS

- CASE** - Diallyl phthalate (DAP)(UL94V-0)
- HOUSING** - Brass, tin plated
- ACTUATOR** - Nylon, black.
- CONTACT** - Silver or gold plated.
- TERMINALS** - Copper alloy, with silver and gold plated. (See Page 98)

HOW TO ORDER

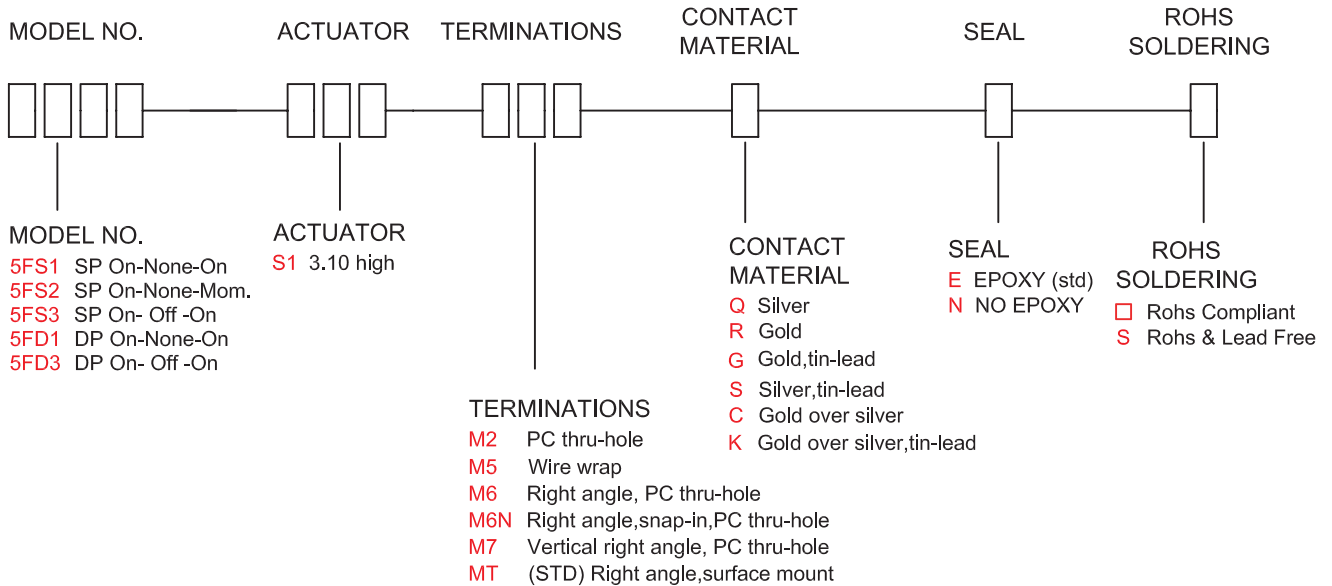

SWITCH FUNCTION

NO. POLES	UL/CSA MODEL NO.	MODEL NO.	SWITCH FUNCTION			CONNECTED TERMINALS / SCHEMATIC		
			POS.1	POS.2	POS.3	POS.1	POS.2	POS.3
SP	Q2511	5FS1	ON	NONE	ON		OPEN	
	Q2512	5FS2	ON	NONE	MOM			
	Q2513	5FS3	ON	OFF	ON			
DP	Q2521	5FD1	ON	NONE	ON		OPEN	
	Q2523	5FD3	ON	OFF	ON			

MOM=MOMENTARY

POLE OPTIONS

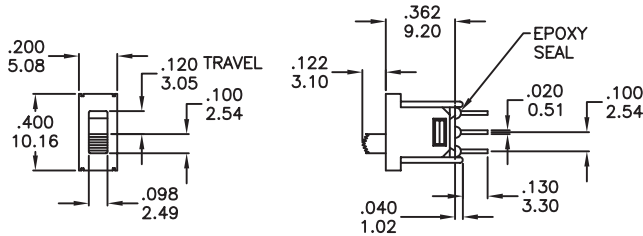

P.C. MOUNTING

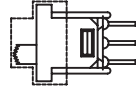
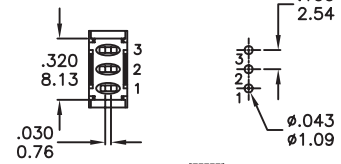

Waterproof transparent cover

SPDT

Part No. Shown : 5FS1S102M2QE

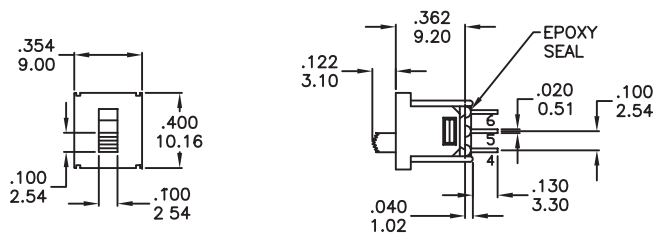

P.C. MOUNTING

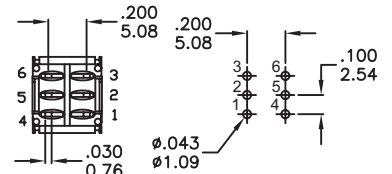

DPDT

Part No. Shown : 5FD1S102M2QE

TERMINATION OPTIONS

M2 PC THRU-HOLE

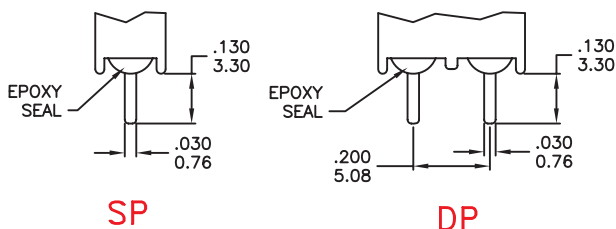

OTHER TERMINATION OPTIONS

- M6 RIGHT ANGLE P.C. MOUNT
- M6N SNAP - IN RIGHT ANGLE P.C. MOUNT

M6

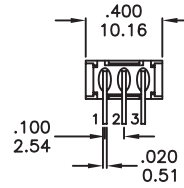
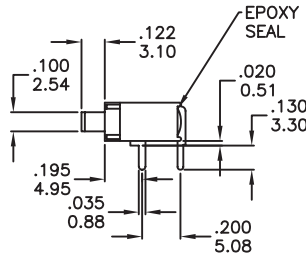
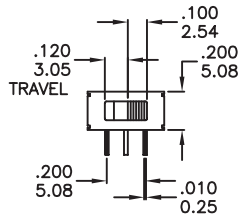

P.C. MOUNTING

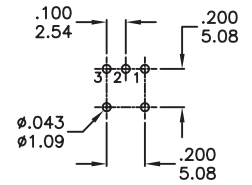

SPDT

Part No. Shown : 5FS1S102M6QE

M6

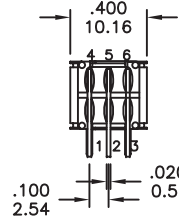
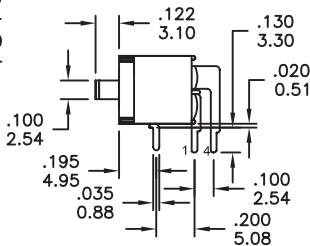
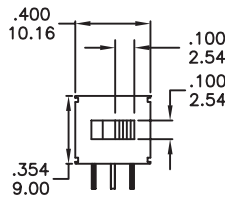

P.C. MOUNTING

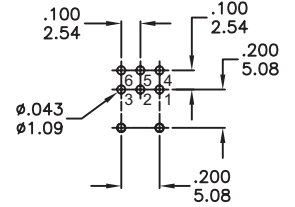

DPDT

Part No. Shown : 5FD1S102M6QE

MZ

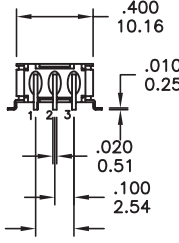
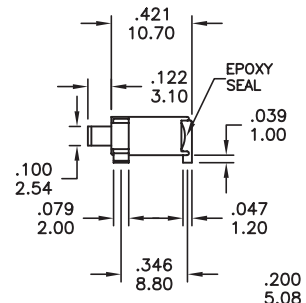
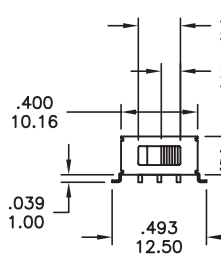

P.C. MOUNTING

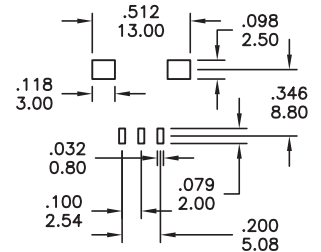

SPDT

Part No. Shown : 5FS1S102MZRES

M7

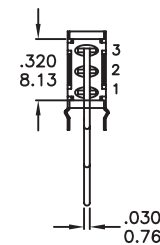
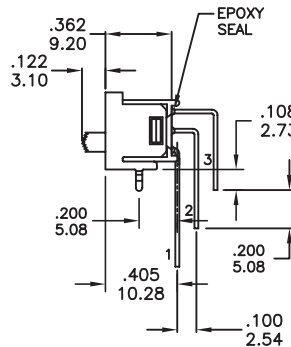
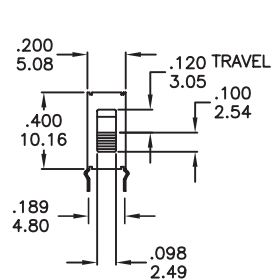

P.C. MOUNTING

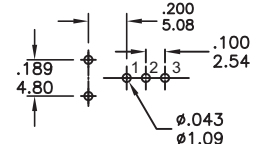

SPDT

Part No. Shown : 5FS1S102M7NRES

SNAP-IN TERMINATION OPTIONS

M6N

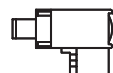

CONTACT MATERIAL OPTIONS

	CONTACT MATERIAL	TERMINAL PLATING	RATINGS
Q	Silver	Q = Silver	3 Amps with resistant load @ 120VAC or 28VDC 1 Amps with resistant load @ 250VAC
S		S = Silver,pure - tin	
C	Gold over Silver	C = Gold over silver	
K		K = Gold over silver,pure - tin	
R	Gold	R = Gold	0.4 Volt-Amps(VA)max. @ 20V max. (AC or DC)
G		G = Gold,pure - tin	



SOLDERING PROCESSES

MANUAL SOLDERING : Use soldering iron of 30 watts, controlled at 350°C approximately 5 seconds while applying solder.

WAVE SOLDERING : Recommended Soldering Temperature: 260±5°C
Duration of Solder Immersion: 5 ±1 seconds
(PCB is 1.6mm in thickness)

SOLDERING : Vapor phase

Temperature Profile

Zone	Room temperature	Time (Sec)
Pre-heat (A)	150°C	Min 120s
Soak (B)	180°C~200°C	Min 150s
Peak (C)	200°C~235°C	Min 30s
Peak (D)	235°C~260°C	Min 40s
Peak (E)	260°C	Max 10s

