

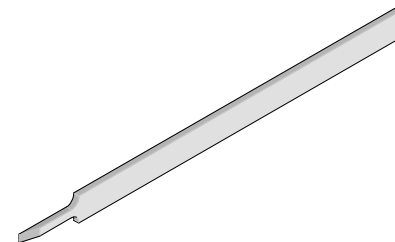

## Extractor Tool Instruction Sheet Order No. 63813-2700



### FEATURES

- This Extractor Tool is for the removal of Wire-to-Wire and Wire-to-Board terminal series in both plug and receptacles.

### SCOPE

Products:

Terminal Series No.	Description	Housing Series	Terminal Order No.		
35053	2.50mm (.098") Pitch Wire-to-Wire Male Terminals	35184	35053-9002		
35465	Earth Terminal for PT Bulb Socket AVSS 0.50-0.85mm <sup>2</sup>	35842 and 35843	35465-8000		
35477	Wedge Terminal 14.50mm (0.57") Pitch	68147	35477-9002		
35725	6.35mm (.250") Tab Slip-On Wire-to-Wire Terminal, Female, 12-18 AWG	35546 and 35547	35725-5110	35725-5210	
35768	2.3mm (.090") Slip-On Receptacle Terminal		35768-0110	35768-0120	
43374	3.18mm (.125") Sabre™ Terminal Receptacle Flat Blade System	41644, 41645 42865, 44167 and 44421	43374-0001		
43375		44441	43375-0001	43375-1001	43375-2001
48105	2.00mm (.079") Pitch, Wire-to-Board Crimp Terminal	48106	48105-0001		
50147	2.50mm (.098") Pitch Splash Proof Crimp Terminal 20-22 AWG	52266	50147-8000	50147-8100	
50148		52213	50148-8000	50148-8100	
50351	2.50mm (.098") Pitch Mini-Lock™ Wire-to-Board and Wire-to-Wire Crimp Terminal	51102, 51163, and 51103	50351-8000	50351-5100	
50539	3.96mm (.156") Pitch Wire-to-Board Crimp Terminal	51144	50539-8000	50539-8100	50539-9001
56086	2.00mm (.079") Pitch Crimp Terminal	51227	56086-8000	56086-8100	
56134	2.00mm (.079") Pitch Crimp Terminal	51242, 51353, and 51382	56134-8000	56134-8100	
			56134-9000	56134-9100	
56187	3.30mm (.130") Pitch Crimp Terminal	51284 and 51347	56187-8000	56187-8100	
57964	1.52mm (.060") OBD-II Male Terminal for AVS (CAVS) 0.3-0.5	68503-1602	57964-9702		
59370	2.00mm (.079") Pitch Crimp Terminal	51216	59370-8000	59370-8100	
501930	1.25mm (.049") Wire-to-Board Dual Plug Crimp Terminals	503110	501930-0100	501930-0200	
			501930-1100	501930-1200	
502057	1.75mm (.069") Pitch Wire-to-Board Crimp Terminal	502056	502057-1000	502057-1100	
78172	1.20mm (.047") Wire-to-Board Crimp Terminals	78172	78172-0410	78172-0411	
87421	1.50mm (.059") Pico-SPOX™ Crimp Terminal Female, 24-30 AWG	87439	87421-0000	87421-0001	
94518	High Normal Force (HNF) Female Terminals, For 6.3x0.8mm (.248"x.031") Tabs, AWG 18-20	90522, 90553 94213 and 94535	94518-0100	94518-0101	94518-0120
			94518-0121	94518-0200	94518-0201
			94518-0220	94518-0221	94518-0300
			94518-0301	94518-0400	94518-0401

**OPERATION:**

**CAUTION:** This extractor tool should be used to extract the terminal only. Using it for unintended purposes may cause injury or damage to parts. Be careful not to deform the end of the terminal. Avoid lifting the housing lock too high.

**For 35053 48105, 78172, 87421, and 502057**

**Terminal Series:**

1. Push the terminal forward into the housing before using the Extractor Tool.
2. Insert the Extractor Tool into the slot on the bottom of the connector housing as shown in Figure 6. Make sure the straight edge of the extractor tool is up against the housing lock.
3. Gently lift up on the housing tab and push the terminal back through the connector slot and pull the terminated wire out in the arrow direction. See Figure 1.

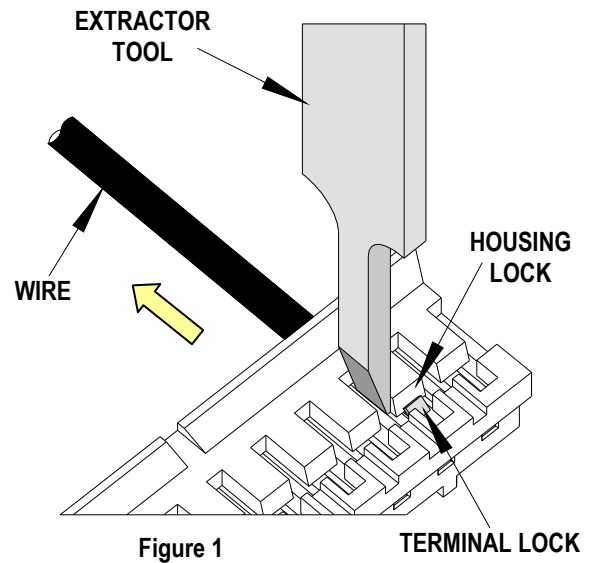

**For 35465 Terminal Series:**

1. Push the terminal and the wire forward in the arrow direction before using this Tool.
2. Insert the Tool into the slot above the locking tang of the terminal.
3. Push the tool down until the locking tang is even with the rest of the terminal. This will free the terminal from the housing.
4. Pull the crimp wire back through the connector slot in the arrow direction as shown in Figure 2.

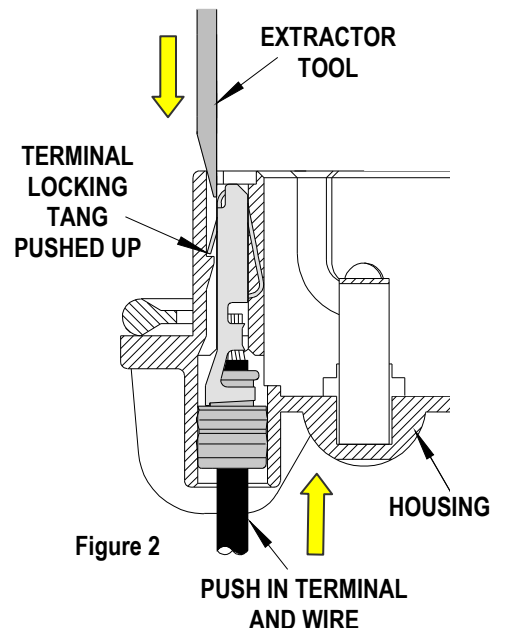

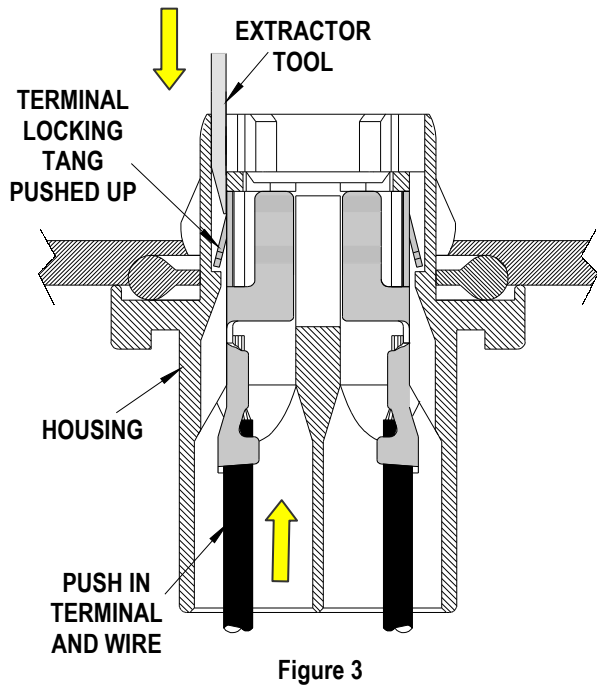

Figure 3

**For 35477 Terminal Series:**

1. Push the terminal and the wire forward in the arrow direction before using this Tool.
2. Insert the Tool into the slot above the locking tang of the terminal.
3. Push the tool down until the locking tang is even with the rest of the terminal. This will free the terminal from the housing.
4. Pull the crimp wire back through the connector slot in the arrow direction as shown in Figure 3.

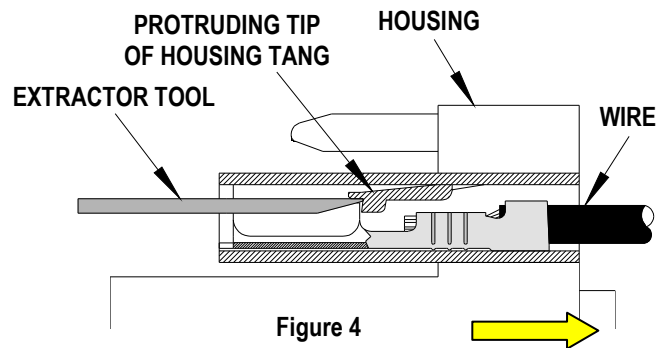

Figure 4

**For 35725 Terminal Series:**

1. Push the terminal and the wire forward into the housing before using this Tool.
2. Insert the Tool into the area above the terminal contact and below the protruding tip of the terminal locking tang in the housing.
3. Lift the locking tab upward until it is above the contact of the terminal. This will free the terminal from the housing.
4. Pull the crimped wire and terminal back through the connector slot in the arrow direction as shown in Figure 4.

**For 35768 Terminal Series:**

1. Push the wire and the terminal forward in the arrow direction before using the Extractor Tool.
2. Insert the Extractor Tool into the slot on the side of the connector housing.
3. While depressing the housing lock, push the terminal back through the connector slot and pull the terminated wire out in the arrow direction. See Figure 5.

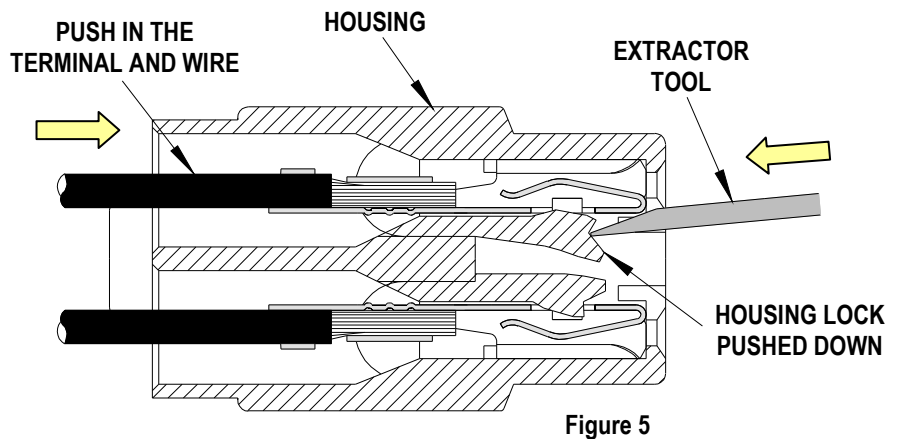

Figure 5

**For 43374 and 43375 Terminal Series:**

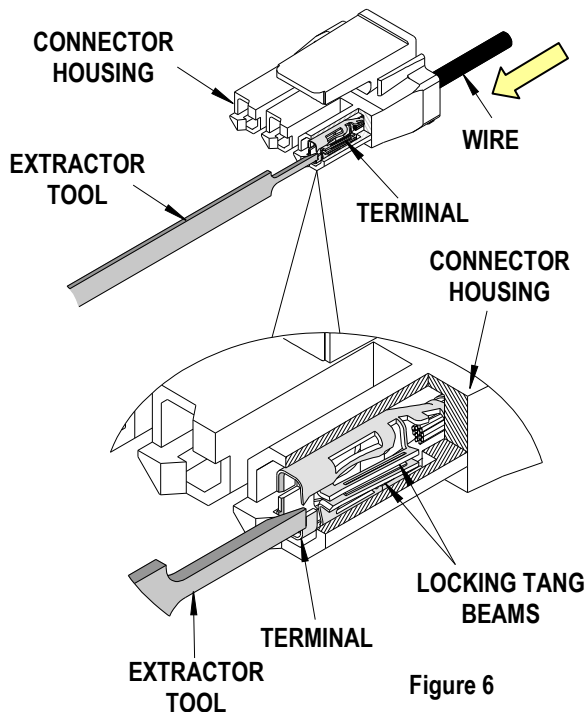

Figure 6

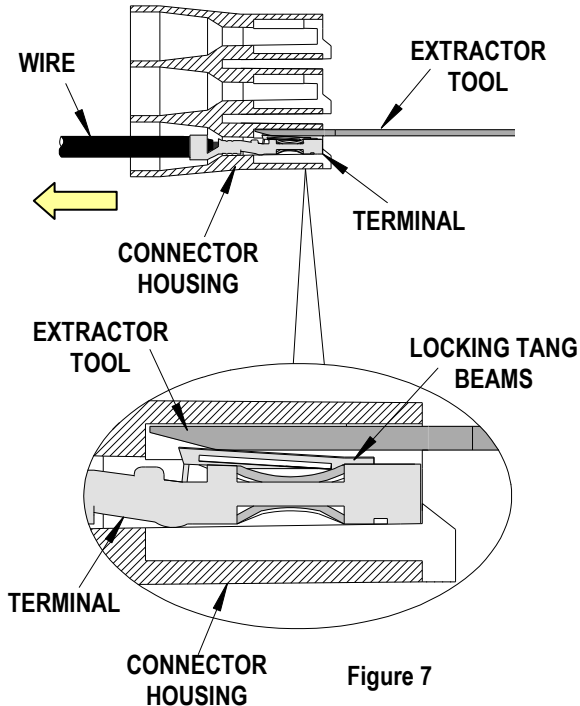

Figure 7

1. Push the terminal forward in the arrow direction before using the Extractor Tool as shown in Figure 6. Insert the Extractor Tool into the slot on the side of the connector housing.
2. Depress the terminal locking tang beams and push the terminal back through the connector slot. Pull the terminated wire out in the arrow direction. See Figure 7.

**For 50147 and 50148 Terminal Series:**

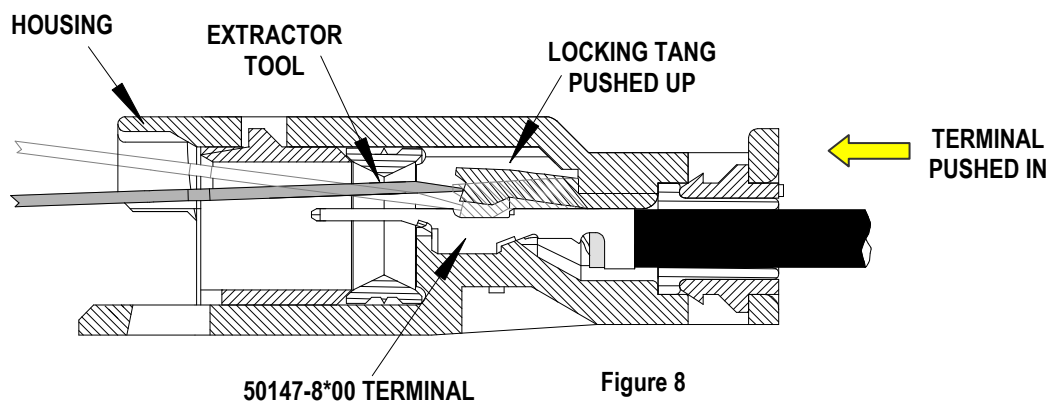
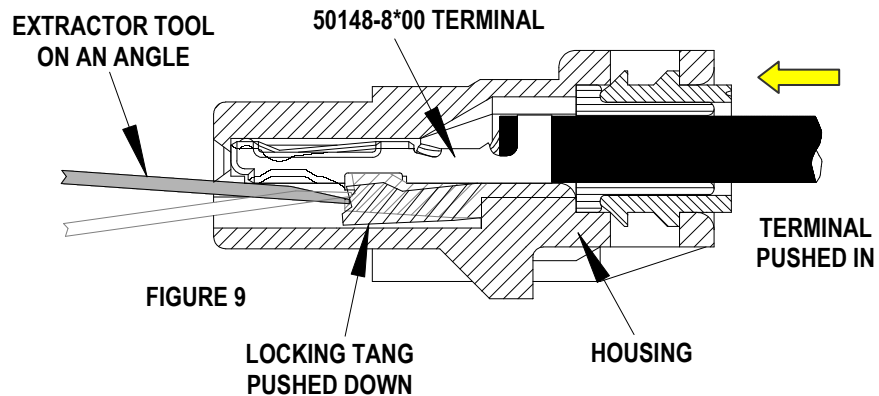

Figure 8

1. For terminal series 50147, push the terminal forward in the arrow direction before using the Extractor Tool.
2. Insert the tip of the Extractor Tool on an angle into the connector housing. See Figure 8.
3. While pushing the extraction tool against the terminal locking tang, bend the locking tang up and away from the terminal. At the same time a second person pulls on the crimped wire to release the terminal from the housing.
4. For terminal series 50148, push the terminal forward in the arrow direction before using the Extractor Tool.

5. Insert the tip of the Extractor Tool on an angle into the connector housing. See Figure 9.
6. While pushing the extraction tool against the terminal locking tang, bend the locking tang down and away from the terminal. At the same time a second person pulls on the crimped wire to release the terminal from the housing.



**For 501930 Terminal Series:**

1. Line up the terminal to be removed in the connector assembly with the tip of the Extractor Tool. Insert and slide the Extractor Tool into the slot on the side of the connector housing as shown. Positioning it under the housing lock as shown in Figure 10.
2. Slide the Extractor Tool in the direction shown lifting up the housing lock. While lifting the housing lock, push the terminal back through the connector slot and pull the terminated wire out in the arrow direction. See Figure 11.

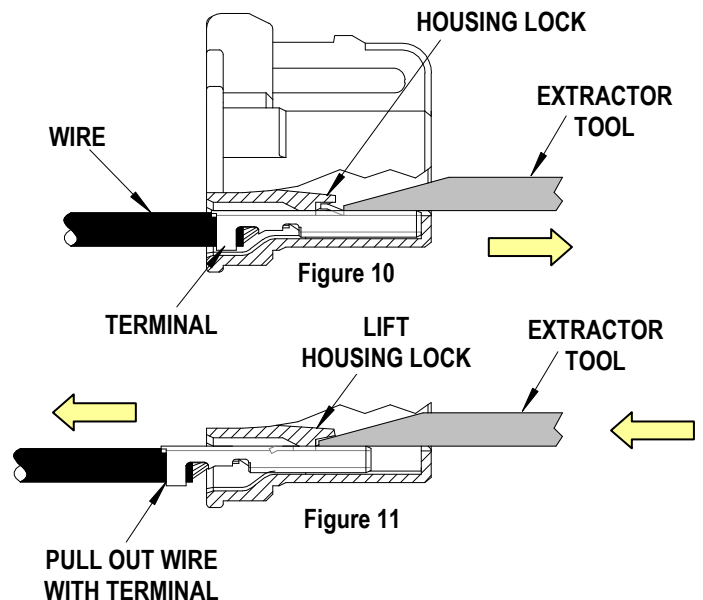

**For 50539 Terminal Series:**

1. Push the terminal forward in the arrow direction before using the Extractor Tool.
2. Insert the Extractor Tool into the slot above the terminal in the connector housing as shown in Figure 12.
3. Gently push the extractor tool till it stops. The housing locking tab should be bent up.
4. Pull the terminal and the terminated wire back through the Connector slot along with the extractor tool in the arrow direction as shown.

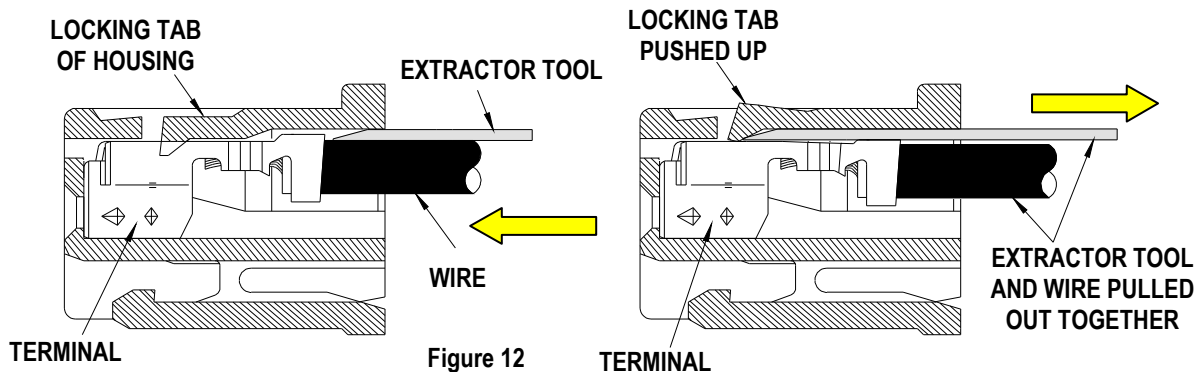

**For 50351 Terminal Series:**

1. Insert the Extractor Tool into the slot on the bottom of the connector housing.
2. Gently lift up on the housing tab, and push the terminal back through the connector slot. While pulling the terminated wire out in the direction of the arrow. See Figure 13.

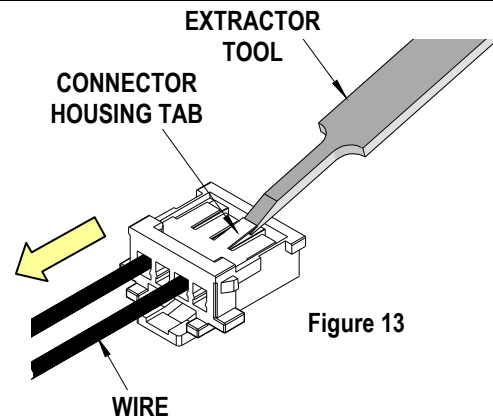

Figure 13

**For 56086, 56134, 56187, 57964, and 59370 Terminal Series:**

1. Push the terminal forward in the arrow direction before using the Extractor Tool. Insert the Extractor Tool into the slot on the side of the connector housing as shown in Figure 14.

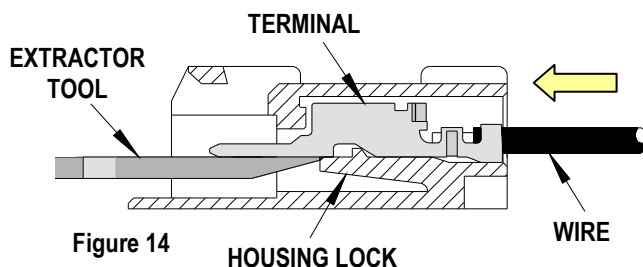

Figure 14

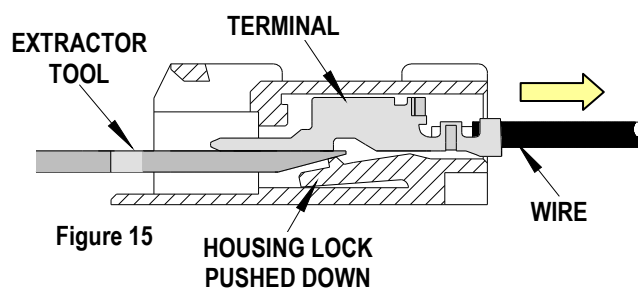

Figure 15

2. While depressing the housing lock, push the terminal back through the connector slot and pull the terminated wire out in the arrow direction. See Figure 15.
3. When using certain housings it may be necessary to insert the Extractor Tool into the slot on the bottom of the connector housing.
4. Gently lift up on the housing tab, and push the terminal back through the connector slot. While pulling the terminated wire out in the direction of the arrow. See Figure 16.

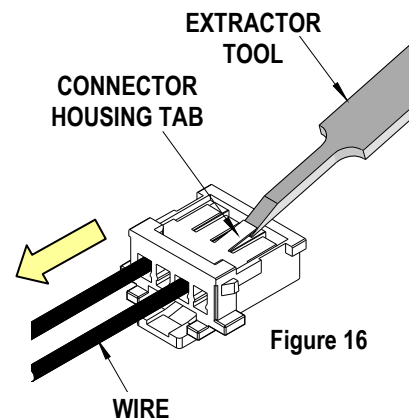
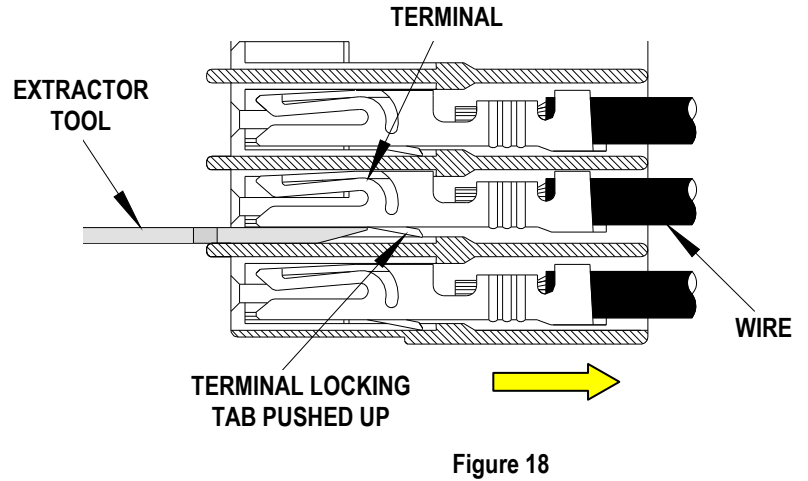
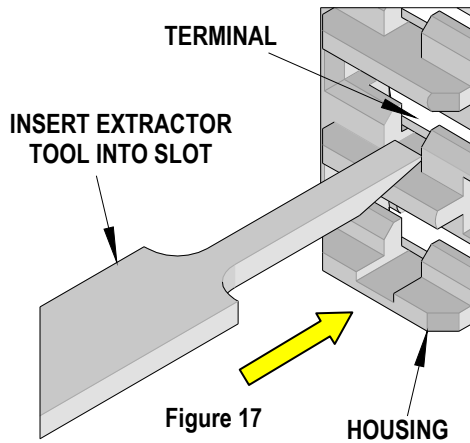

Figure 16

**CAUTION:** Do not reuse the 51242, 51353, and 51382 housings series once the terminals are extracted.

**For 94518 Terminal Series:**

1. Push the wire of the crimped terminal to be removed forward into the connector housing before using the Extractor Tool.
2. Insert the Extractor Tool into the slot below the terminal, seated in the connector housing and slide it forward until it stops. See Figure 17.
3. Pull the wire and terminal back through the Connector slot in the arrow direction as shown. See Figure 18.



**CAUTION:** Molex specifications are valid only when used with Molex terminals, applicators and tooling.

Molex does not offer repair parts for Extraction Tools due to the inexpensive nature of the tool.

**Americas Headquarters**  
Lisle, Illinois 60532 U.S.A.  
1-800-78MOLEX  
amerinfo@molex.com

**Far East North Headquarters**  
Yamato, Kanagawa, Japan  
81-462-65-2324  
feninfo@molex.com

**Far East South Headquarters**  
Jurong, Singapore  
65-6-268-6868  
fesinfo@molex.com

**European Headquarters**  
Munich, Germany  
49-89-413092-0  
eurinfo@molex.com

**Corporate Headquarters**  
2222 Wellington Ct.  
Lisle, IL 60532 U.S.A.  
630-969-4550  
Fax: 630-969-1352

Visit our Web site at <http://www.molex.com>