

THIS DRAWING IS UNPUBLISHED. RELEASED FOR PUBLICATION
 © COPYRIGHT BY TYCO ELECTRONICS CORPORATION. ALL INTERNATIONAL RIGHTS RESERVED.

LOC	DIST	REVISIONS			
P	LTR	DESCRIPTION	DATE	DWN	APVD
GP	00	H	REVISED PER ECO-08-007460	17JUN2008	ZMRCWR

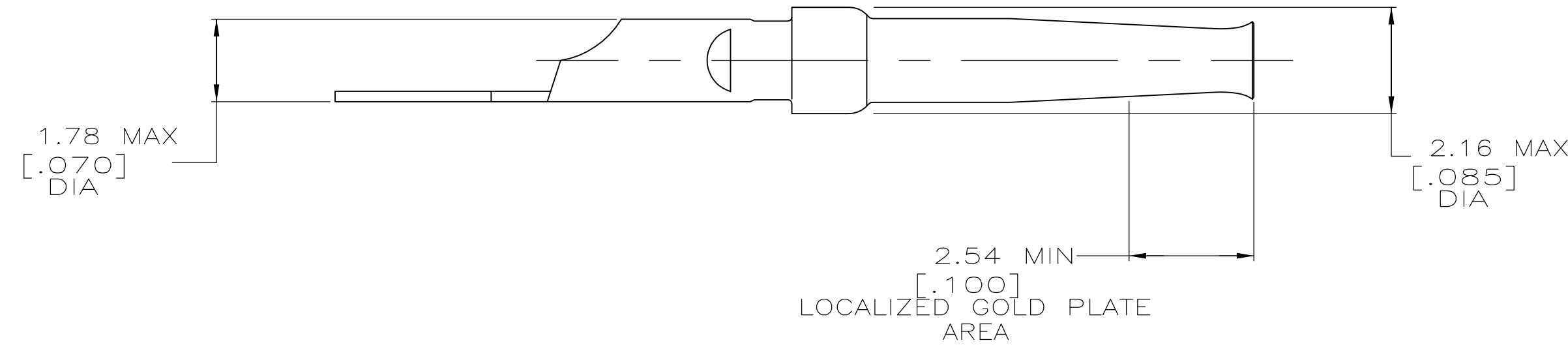
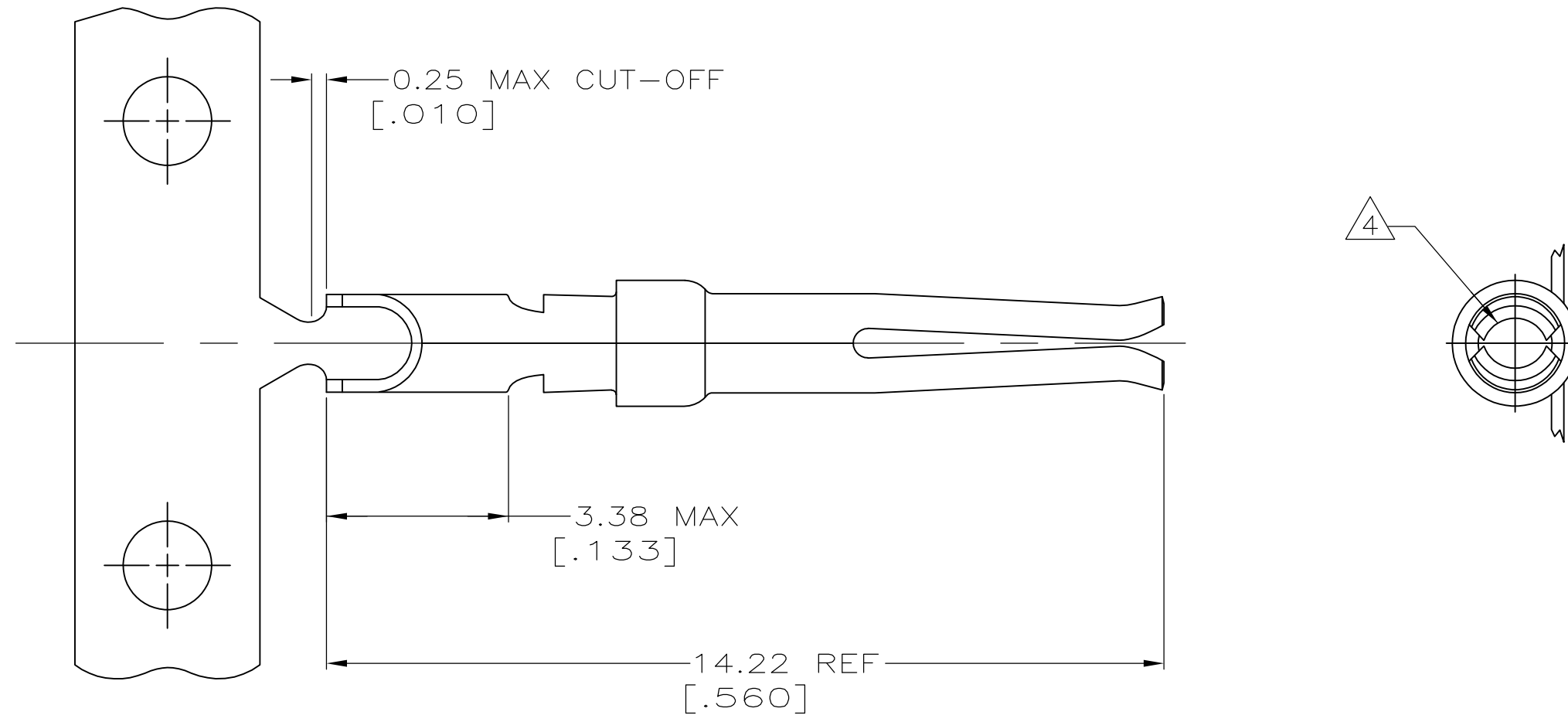

- 1 PHOSPHOR BRONZE PER QQ-B-750.
- 2 GOLD PLATED IN LOCALIZED GOLD PLATE AREA AS FOLLOWS:
 PLATED WITH 0.76µm [.000030] GOLD IN LOCALIZED GOLD PLATE AREA, GOLD FLASH ON REMAINDER, OVER 1.27µm [.000050] MIN NICKEL.
 OR
 GOLD FLASH OVER PALLADIUM-NICKEL PLATE, 0.76µm [.000030] MIN TOTAL IN LOCALIZED GOLD PLATE AREA, GOLD FLASH ON REMAINDER, OVER 1.27µm [.000050] MIN NICKEL.
- 3 GOLD PLATING PER MIL-G-45204, NICKEL PLATING PER QQ-N-290.
- 4 WILL ACCEPT 1.02 [.040] DIA PIN.
- 5. 1.17 [.046] MAX DIA CONDUCTOR (UP TO 18 AWG).

PACKAGING	TYPE	PART NUMBER
SMALL PACK	LOOSE PIECE	1-66569-0
STANDARD	LOOSE PIECE	66569-3
-	STRIP	66569-2

THIS DRAWING IS A CONTROLLED DOCUMENT.		DWN D.HARDY 08 NOV 95	Tyco Electronics Corporation Harrisburg, PA 17105-3608													
DIMENSIONS: mm [INCHES]		CHK R.STONE 14 NOV 95														
TOLERANCES UNLESS OTHERWISE SPECIFIED:		APVD C.STINSON 06 DEC 95														
<table border="1"> <tr><td>0 PLC</td><td>± -</td></tr> <tr><td>1 PLC</td><td>± -</td></tr> <tr><td>2 PLC</td><td>± -</td></tr> <tr><td>3 PLC</td><td>± -</td></tr> <tr><td>4 PLC</td><td>± -</td></tr> <tr><td>ANGLES</td><td>± -</td></tr> <tr><td>FINISH</td><td>± -</td></tr> </table>		0 PLC			± -	1 PLC	± -	2 PLC	± -	3 PLC	± -	4 PLC	± -	ANGLES	± -	FINISH
0 PLC	± -															
1 PLC	± -															
2 PLC	± -															
3 PLC	± -															
4 PLC	± -															
ANGLES	± -															
FINISH	± -															
MATERIAL 1	FINISH 2 3	APPLICATION SPEC -	NAME SOCKET CONTACT, SIZE 20 DF, WITH SOLDER CUP, AMPLIMITE	RESTRICTED TO -												
CUSTOMER DRAWING		WEIGHT -	SIZE A2	CAGE CODE 00779												
		SCALE 10:1	DRAWING NO C=66569	SHEET 1 of 1												
			REV H													