

Model No.	POS.1	POS.2	POS.3
1MD3	ON	OFF	ON
Term. Comm.	2-3,5-6	OPEN	2-1,5-4
SCHEMATIC			

SWITCH FUNCTION

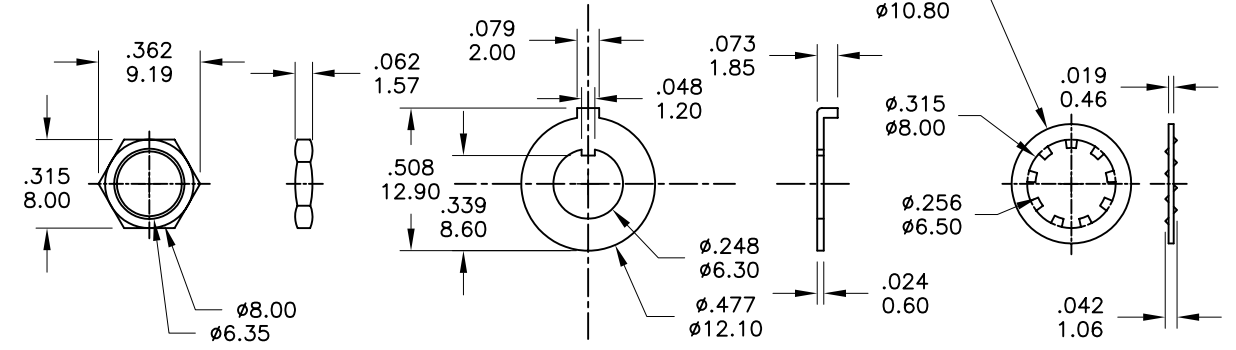
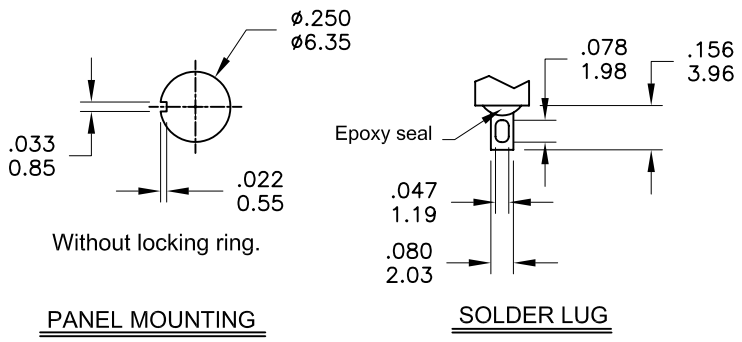

SPECIFICATIONS

MECHANICAL LIFE: 40,000 make-and-break cycles.
CONTACT RESISTANCE: 10mΩ max. initial @ 2-4VDC
 100mA for both silver and gold plated contacts.
INSULATION RESISTANCE: 1,000MΩ min.
DIELECTRIC STRENGTH: 1,000 V RMS@sea level.
OPERATING TEMPERATURE: -30°C to 85°C.

MATERIALS

CASE: Dially phthalate (DAP) (UL94v-0).
ACTUATOR: Brass,chrome plated.
BUSHING: Brass,nickel plated.
HOUSING: Stainless Steel.
TERMINAL/CONTACT: Silver or gold plated.



RATING :

R : 0.4 Volt-Amps(VA) max. @20V max.(AC or DC)
 Q : 2Amps @250VAC
 5Amps @120 VAC or 28 VDC

REV.	符號	原尺寸	修改後尺寸	變更日期	SCALE (比例) : 3 : 2	TITLE 圖名	Miniature Toggle Switches	SIZE 圖紙	A4		
1	(A)				TOLERANCE (公差) : 0.00 mm ± 0.25mm 0.0 mm ± 0.40mm ANGULAR : ± 5° FILE NAME : 1MDP0660	DWG NO. 圖號	1MD3T1B1M1QES-5	UNIT 單位	inch mm		
2	(B)					REV. 版本	A	DATE 日期	JAN - 03 - 2006	SHEET 張數	1 of 1
3	(C)					CHECKED BY 審核	RICHARD		DRAWN BY 製圖	LIN	
4	(D)										
5	(E)										