

THIS DRAWING IS UNPUBLISHED. RELEASED FOR PUBLICATION
 © COPYRIGHT BY TYCO ELECTRONICS CORPORATION. ALL RIGHTS RESERVED.

LOC		DIST		REVISIONS			
P	LTR	DESCRIPTION		DATE	DWN	APVD	
CM	00	R		REVISED PER ECO-09-013245	04JUN09	HMR	MS

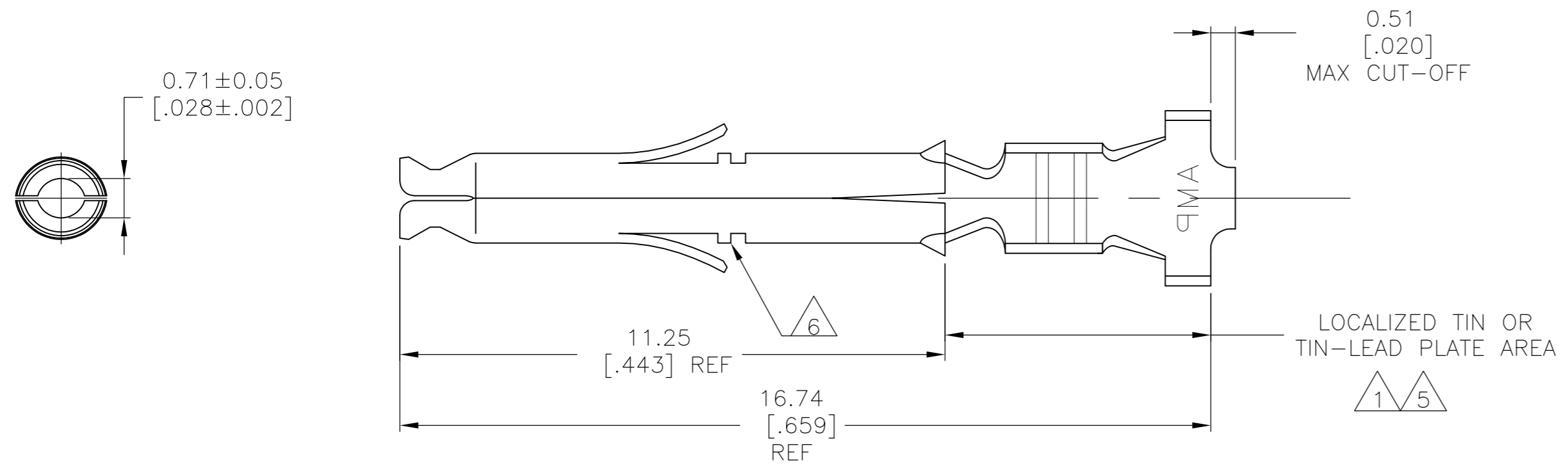

- 1 0.00076 [.000030] MIN GOLD IN LOCALIZED GOLD PLATE AREA AND 0.00254 [.000100] MIN BRIGHT TIN-LEAD IN LOCALIZED TIN-LEAD PLATE AREA OVER 0.0013 [.000050] MIN NICKEL.
- 2. WIRE RANGE: 0.3-0.9mm² (22-18 AWG).
- 3. INSULATION RANGE: 1.50-2.39[.059-.094] DIA.
- 4. DIMENSIONS IN BRACKETS ARE IN INCHES.
- 5 0.00076 [.000030] MIN GOLD IN LOCALIZED GOLD PLATE AREA AND 0.00254 [.000100] MIN BRIGHT TIN IN LOCALIZED TIN PLATE AREA OVER 0.0013 [.000050] MIN NICKEL.
- 6 LANCE STOPS ARE AN OPTIONAL CONSTRUCTION AND MAY NOT BE PRESENT ON ALL PARTS.

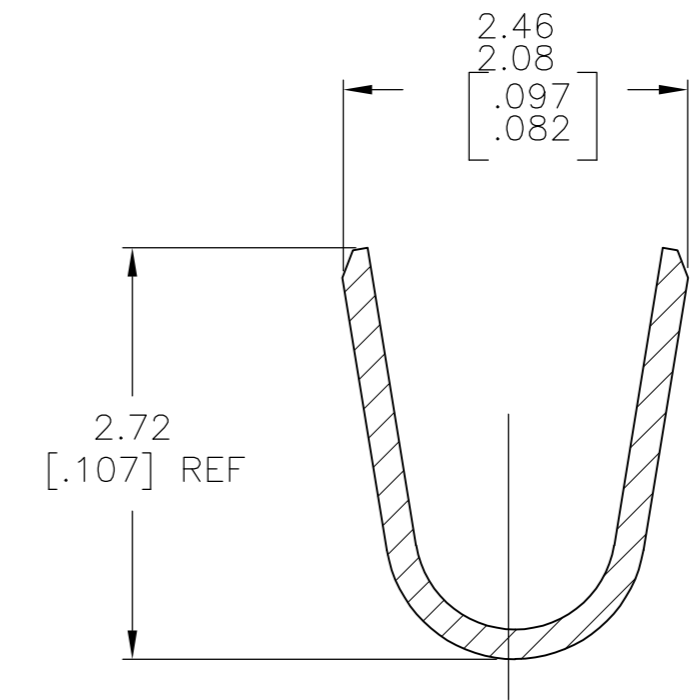
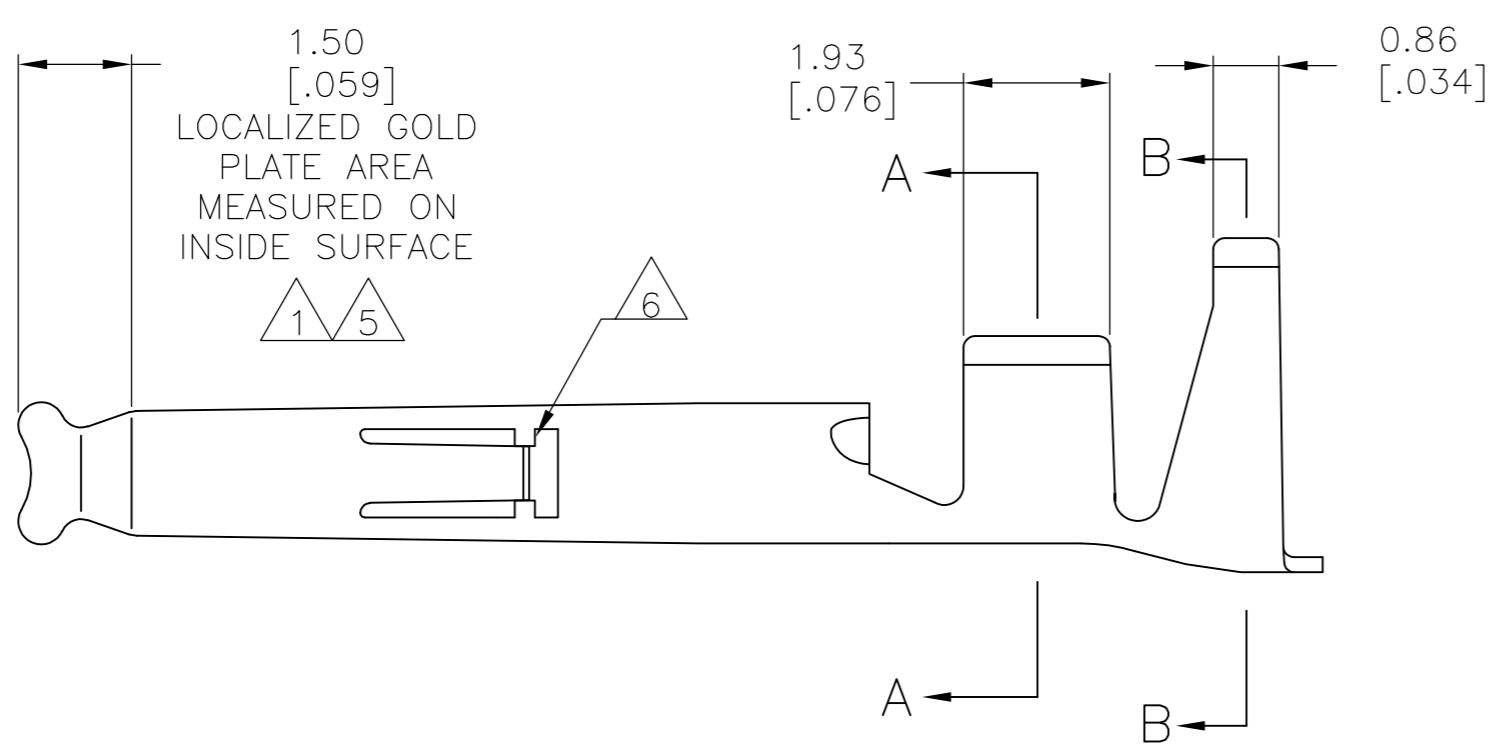

SECTION A-A
SCALE 20:1

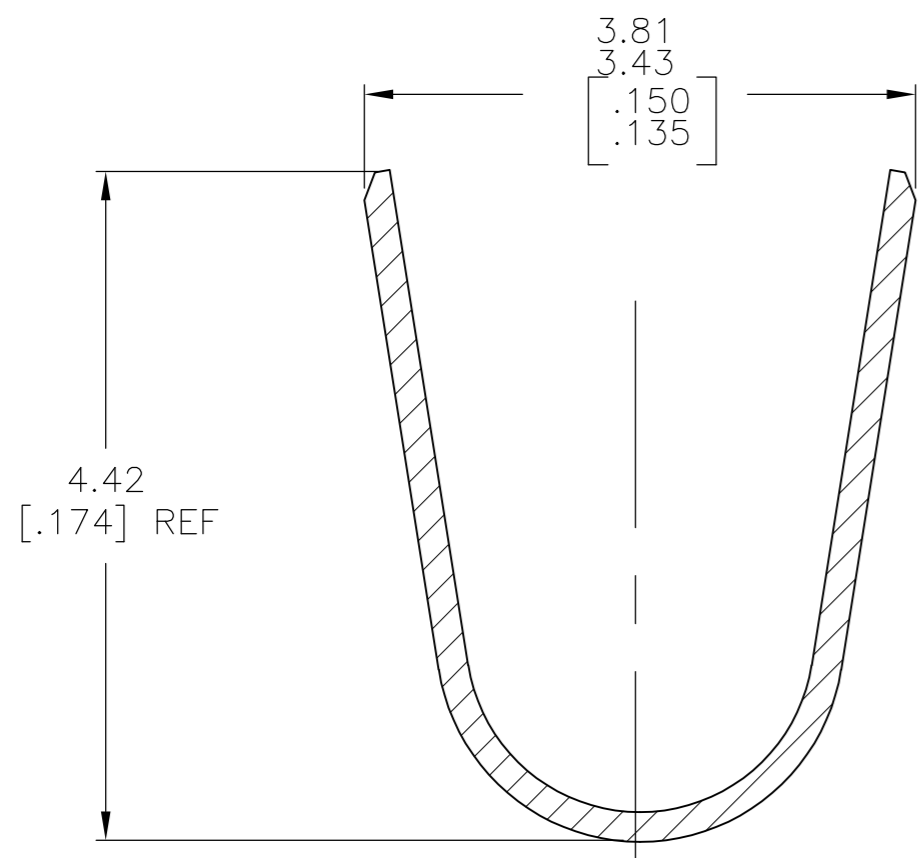

SECTION B-B
SCALE 20:1

FINISH	MATERIAL	PART NUMBER
5	0.20 [.008] PH BRZ	1-770904-1
5	0.20 [.008] BRASS	1-770904-0
1	0.20 [.008] PH BRZ	770904-6
PRE-TIN	0.20 [.008] PH BRZ	770904-4
1	0.20 [.008] BRASS	770904-3
PRE-TIN	0.20 [.008] BRASS	770904-1

THIS DRAWING IS A CONTROLLED DOCUMENT.

DWN	S. HOOVER	17OCT02
CHK	C. JONES	17OCT02
APVD	C. JONES	17OCT02
PRODUCT SPEC		
APPLICATION SPEC		
WEIGHT	-	
CUSTOMER DRAWING		

Tyco Electronics Tyco Electronics Corporation
Harrisburg, PA 17105-3608

NAME: SOCKET, MINI UNIVERSAL MATE-N-LOK(TM)

SIZE	CAGE CODE	DRAWING NO	RESTRICTED TO
A2	00779	C=770904	-
SCALE	SHEET	REV	
10:1	1 of 1	R	

METRIC

770904

A