

NO	DESCRIPTION	DATE
①	MODIFICATION PARTS ③ DC-18 GHz → DC-6 GHz 1.23 MAX. → 1.3 MAX. ADD 5.2 ; REMARK ; TABLE	08.13.10'
②	ADD 2.3 MAX. PANEL	05.14.12'
③	6Kg/cm ² → 7Kg/cm ²	08.01.12'
④	DEL PROOF VOLTAGE WORKING VOLTAGE → VOLTAGE RATING	01.02.13'

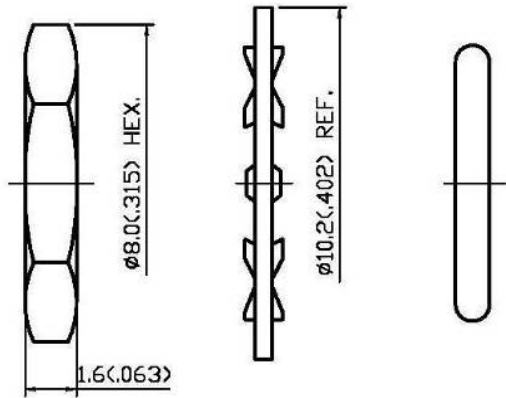

1.0 ELECTRICAL

- 1.1 FREQUENCY RANGE: DC-6 GHz ①
- 1.2 NOMINAL IMPEDANCE: 50 OHM
- 1.3 VOLTAGE RATING: 500 VOLTS MAX. ④
- 1.4 VSWR: 1.3 MAX. ①

2.0 MATERIALS

- 2.1 BODIES: BRASS PER JIS-C3604
- 2.2 CENTER CONTACT: BERYLLIUM COPPER PER ASTM B196 UNS C17300
- 2.3 INSULATION: TEFLON PER ASTM D1457 AND ASTM D1710

3.0 FINISHES AND OTHERS

- 3.1 SEE BELOW TABLE FOR DETAILS.

4.0 MECHANICAL

- 4.1 INTERFACE IN ACCORDANCE WITH: MIL-STD-348A

5.0 ENVIRONMENTAL

- 5.1 OPERATING TEMPERATURE RANGE: -85° C TO +185° C
- 5.2 CONNECTOR MUST WITHSTAND WATERPROOF LEAK TEST PRESSURE 7Kg/cm² MIN. ① ③

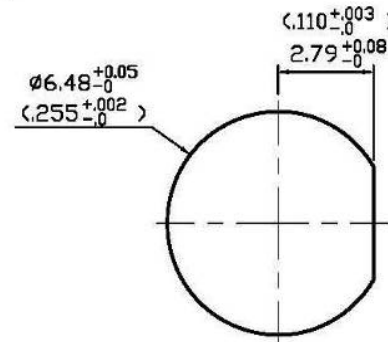
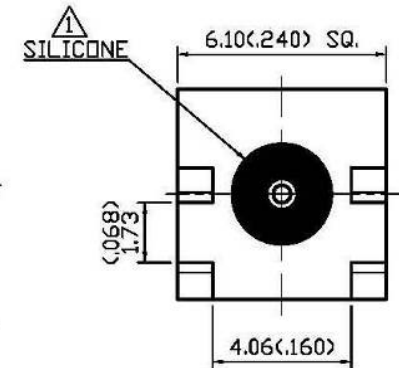
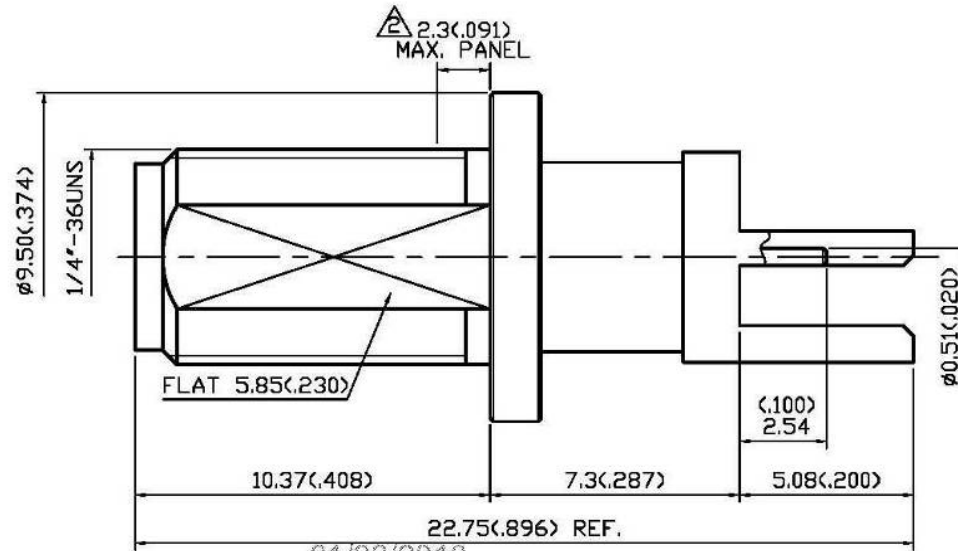

MOUNTING HOLE

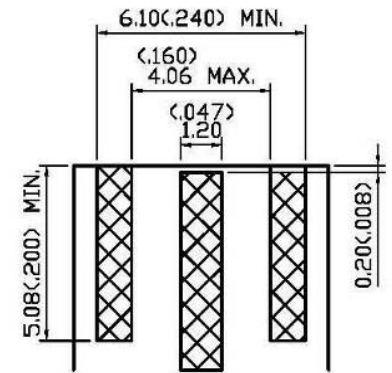

RECOMMENDED PCB LAYOUT

APPROVED

by _____ DATE: _____

NO	DESCRIPTION	MATERIAL	Q'TY	FINISH
6	NUT	BRASS	1	NICKEL
5	WASHER	BRASS	1	NICKEL
4	O-RING	SILICONE	1	BLACK
3	INSULATION	TEFLON	1	NONE
2	CENTER CONTACT	BERYLLIUM COPPER	1	GOLD 50μ" MIN.
1	BODY	BRASS	1	NICKEL 100μ" MIN.

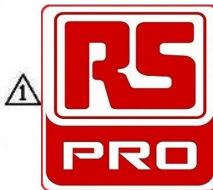

DESCRIPTION		SMA END LAUNCH JACK RECEPTACLE	
製圖	DRAWN Kristina	TOLERANCE	品名 19-70-14 T.G.N
檢圖	CHECK Arc	單位 mm(in)	DATE 03.31.10'
認定	APPROVAL Angela	比例 6:1	版次 A-4
		DWG.NO.	19-0092
		ROHS COMPLIANT (50Ω)	