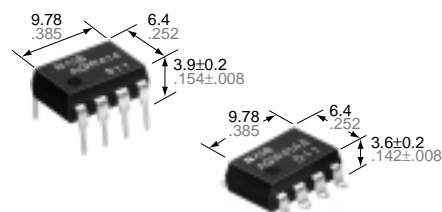
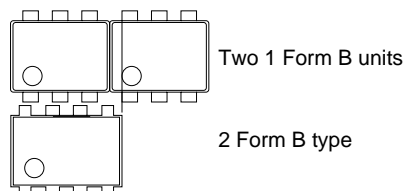

NAIS**GU (General Use) Type
2-Channel (Form B) Type****PhotoMOS
RELAYS****UL File No.: E43149
CSA File No.: LR26550****FEATURES****1. Approx. 1/2 the space compared with the mounting of Two 1 Form B PhotoMOS units**

mm inch

- 2. Applicable for 2 Form B use as well as two independent 1 Form B use**
- 3. Low thermal electromotive force (Approx. 1 μ V)**
- 4. Eliminates the need for a counter electromotive force protection diode in the drive circuits on the input side**
- 5. Controls load currents up to 0.13 A with an input current of 5 mA**
- 6. High speed switching: operate time typical of 300 μ sec.**
- 7. Eliminates the need for a power supply to drive the power MOSFET**
- 8. Extremely low closed-circuit offset voltages to enable control of small analog signals without distortion**
- 9. Surface-mount model available**

TYPICAL APPLICATIONS

- High-speed inspection machines
- Telephone equipment
- Computer

TYPES

	Output rating*		Part No.				Packing quantity	
	Load voltage	Load current	Through hole terminal	Surface-mount terminal			Tube	Tape and reel
			Tube packing style	Tape and reel packing style				
AC/DC type	400 V	100 mA	AQW414	AQW414A	Picked from the 1/2/3-pin side	Picked from the 4/5/6-pin side	1 tube contains 40 pcs. 1 batch contains 400 pcs.	1,000 pcs.

* Indicate the peak AC and DC values.

Note: For space reasons, the package type indicator "X" and "Z" are omitted from the seal.

RATING**1. Absolute maximum ratings (Ambient temperature: 25°C 77°F)**

Item	Symbol	AQW414(A)	Remarks	
Input	LED forward current	I_F	50 mA	
	LED reverse voltage	V_R	3 V	
	Peak forward current	I_{FP}	1 A	f = 100 HZ, Duty factor = 0.1 %
	Power dissipation	P_{in}	75 mW	
Output	Load voltage	V_L	400 V	
	Continuous load current	I_L	0.1 A	Peak AC, DC $I_L = \text{Max. } 0.13 \text{ A (when used for 1 Form B)}$
	Peak load current	I_{peak}	0.3 A	100 ms (1shot), $V_L = \text{DC}$
	Power dissipation	P_{out}	800 mW	
Total power dissipation		P_T	850 mW	
I/O isolation voltage		V_{iso}	1,500 V AC	Between input and output/between contact sets
Temperature limits	Operating	T_{opr}	-20°C to +80°C -4°F to +176°F	Non-condensing at low temperatures
	Storage	T_{stg}	-40°C to +100°C -40°F to +212°F	

2. Electrical characteristics (Ambient temperature: 25°C 77°F)

Item		Symbol	AQW414(A)	Condition	
Input	LED operate (OFF) current	Minimum Typical Maximum	I_{Foff}	0.7 mA 3 mA	$I_L = 100$ mA
	LED reverse (ON) current	Minimum Typical Maximum	I_{Fon}	0.4 mA 0.64 mA	$I_L = 100$ mA
	LED dropout voltage	Minimum Typical Maximum	V_F	1.14 V (1.25 V at $I_F = 50$ mA) 1.5 V	$I_F = 5$ mA
Output	On resistance	Minimum Typical Maximum	R_{on}	26 Ω 50 Ω	$I_F = 0$ mA $I_L = 100$ mA Within 1 s on time
	Off state leakage current	Minimum Typical Maximum	—	1 μ A	$I_F = 5$ mA $V_L = 400$ V
Transfer characteristics	Operate (OFF) time*	Minimum Typical Maximum	T_{off}	0.46 ms 1 ms	$I_F = 0$ mA \rightarrow 5 mA $I_L = 100$ mA
	Reverse (ON) time*	Minimum Typical Maximum	T_{on}	0.40 ms 1 ms	$I_F = 5$ mA \rightarrow 0 mA $I_L = 100$ mA
	I/O capacitance	Minimum Typical Maximum	C_{iso}	0.8 pF 1.5 pF	f = 1 MHz $V_B = 0$
	Initial I/O isolation resistance	Minimum Typical Maximum	R_{iso}	1,000 M Ω	500 V DC

*Operate/Reverse time

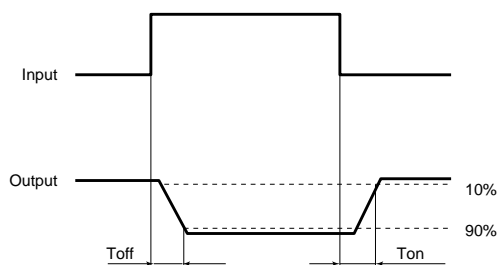

REFERENCE DATA

1. Load current vs. ambient temperature characteristics

Allowable ambient temperature: -20°C to +80°C
-4°F to +176°F

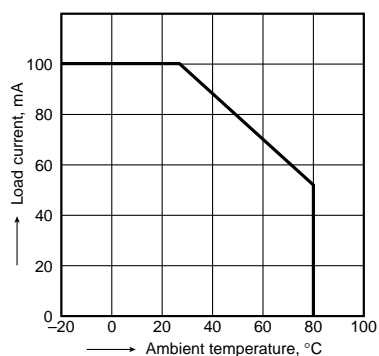

2. On resistance vs. ambient temperature characteristics

Measured portion: between terminals 5 and 6, 7 and 8;
LED current: 0 mA;
Continuous load current: 100 mA (DC)

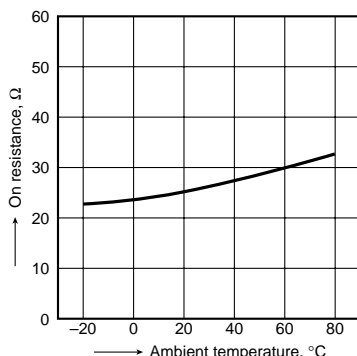

3. Turn on time vs. ambient temperature characteristics

LED current: 5 mA; Load voltage: 400 V (DC);
Continuous load current: 100mA (DC)

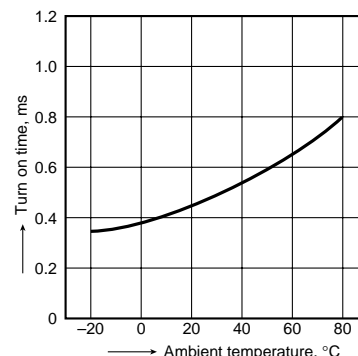

4. Turn off time vs. ambient temperature characteristics

LED current: 5 mA; Load voltage: 400 V (DC); Continuous load current: 100 mA (DC)

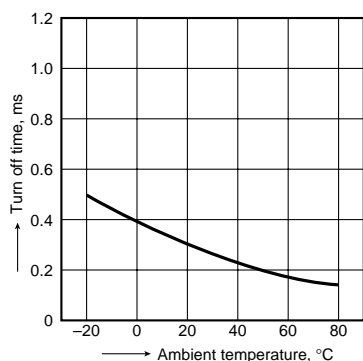

5. LED operate current vs. ambient temperature characteristics

Load voltage: 400 V (DC); Continuous load current: 100 mA (DC)

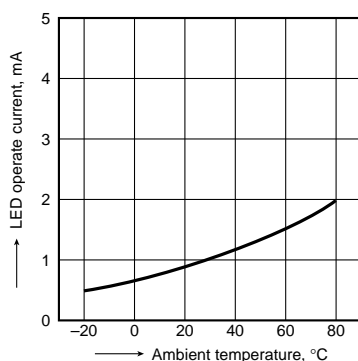

6. LED turn off current vs. ambient temperature characteristics

Load voltage: 400 V (DC); Continuous load current: 100 mA (DC)

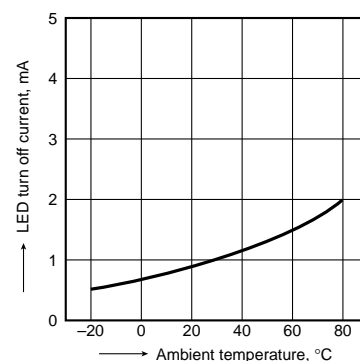

7. LED dropout voltage vs. ambient temperature characteristics

LED current: 5 to 50 mA

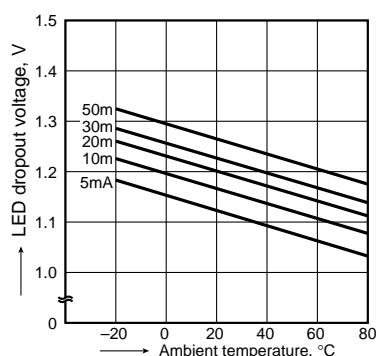

8. Voltage vs. current characteristics of output at MOS portion

Measured portion: between terminals 5 and 6, 7 and 8; Ambient temperature: 25°C 77°F

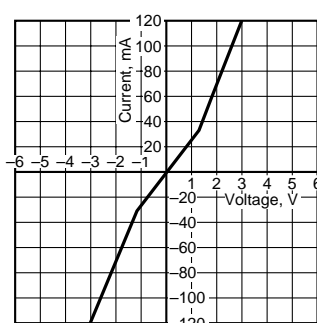

9. Off state leakage current

Measured portion: between terminals 5 and 6, 7 and 8; Ambient temperature: 25°C 77°F

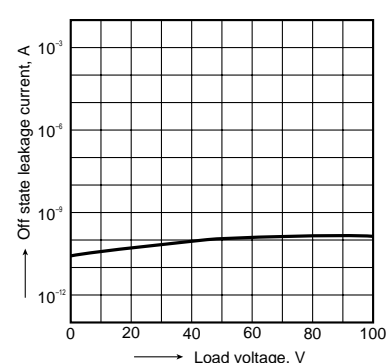

10. LED forward current vs. turn on time characteristics

Measured portion: between terminals 5 and 6, 7 and 8; Load voltage: 400V (DC); Continuous load current: 100mA (DC); Ambient temperature: 25°C 77°F

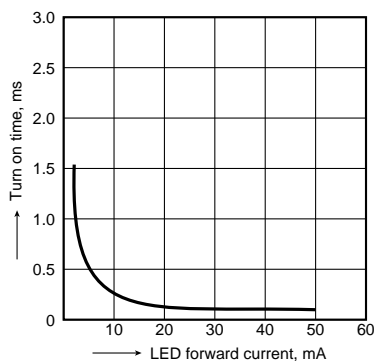

11. LED forward current vs. turn off time characteristics

Measured portion: between terminals 5 and 6, 7 and 8; Load voltage: 400V (DC); Continuous load current: 100mA (DC); Ambient temperature: 25°C 77°F

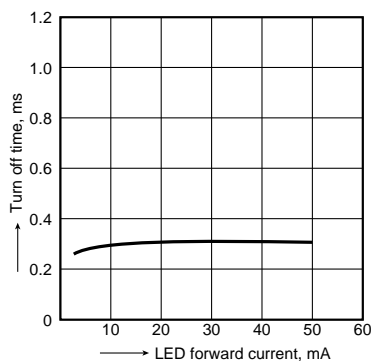

12. Applied voltage vs. output capacitance characteristics

Measured portion: between terminals 5 and 6, 7 and 8; Frequency: 1 MHz; Ambient temperature: 25°C 77°F

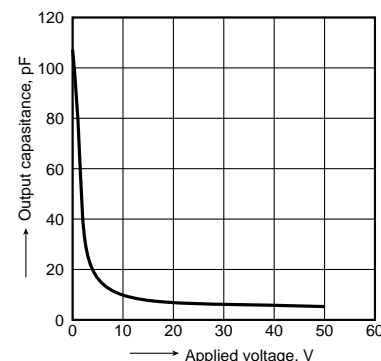

PhotoMOS Relay Technical Information

How PhotoMOS Relays Operate:

Optoelectronic device directly drives a power MOSFET. Semiconductor relay incorporating the advantages of both electromagnetic relays and semiconductors.

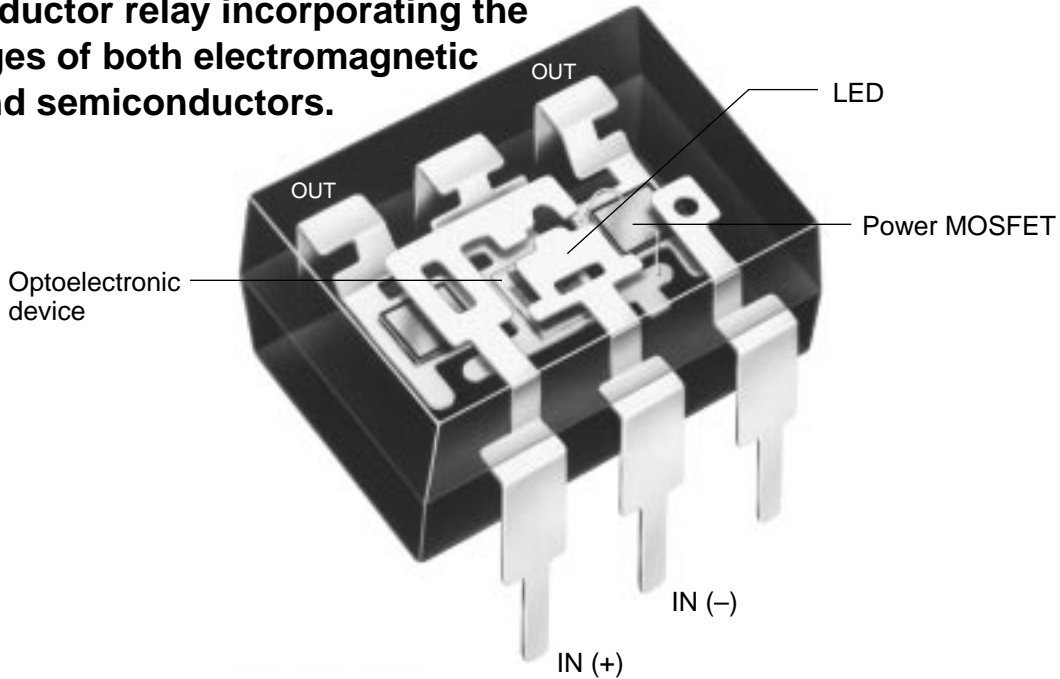

When operated

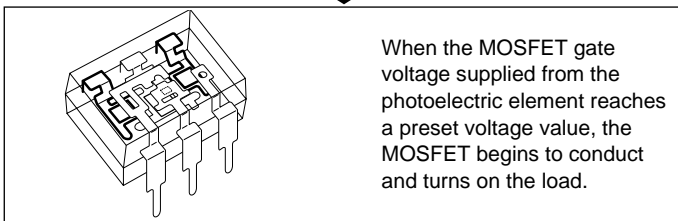
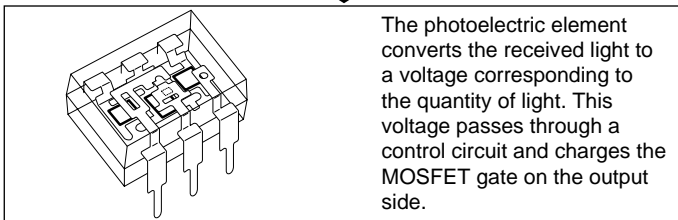
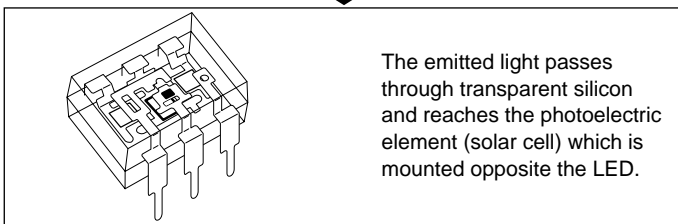
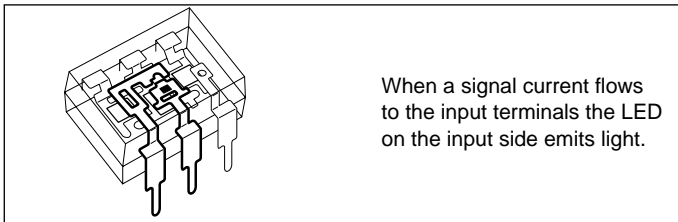



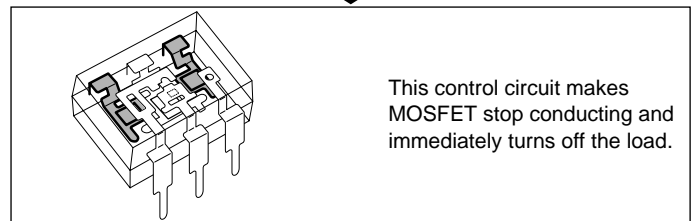
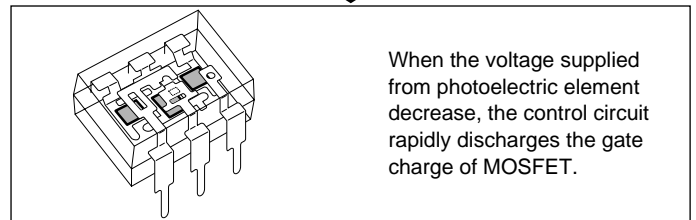
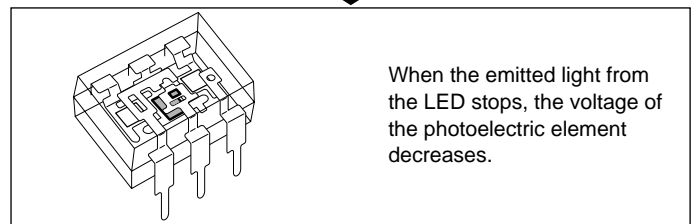
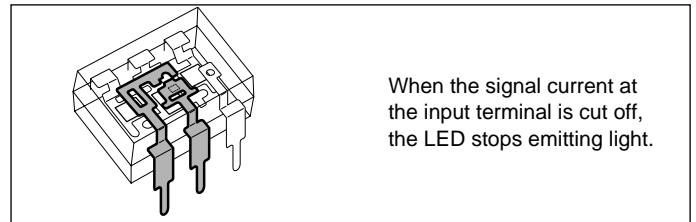





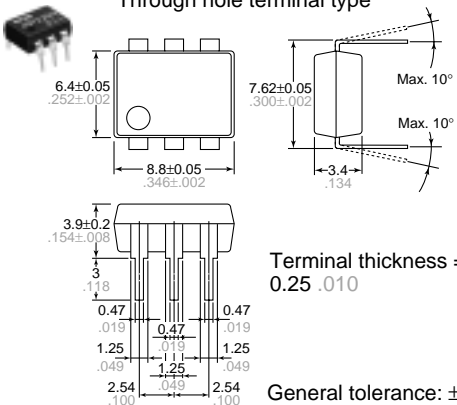
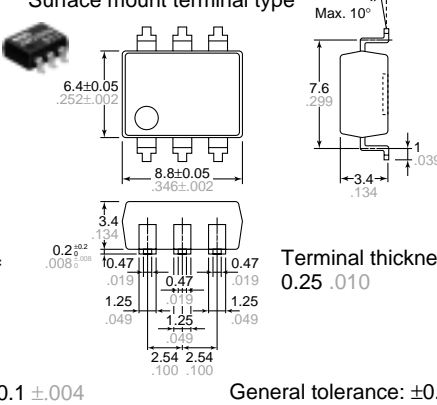
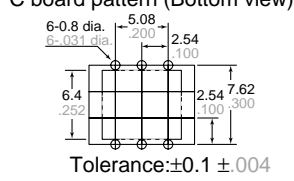
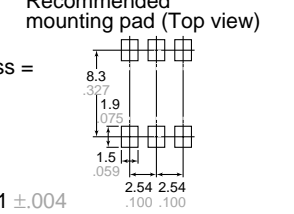
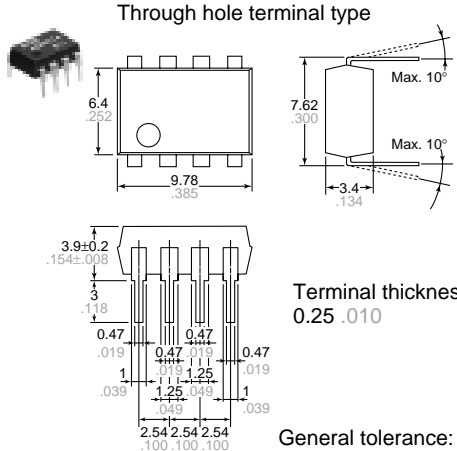
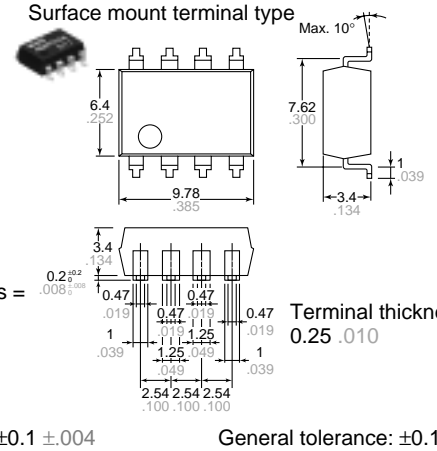
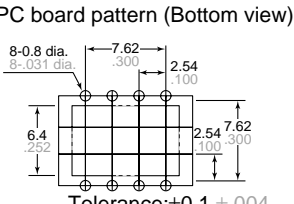
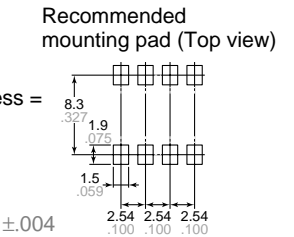
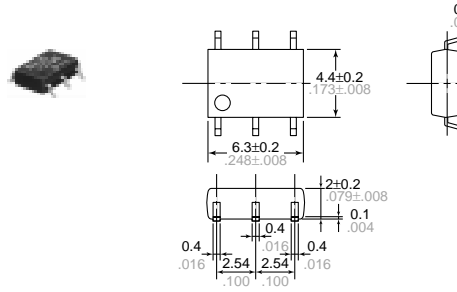
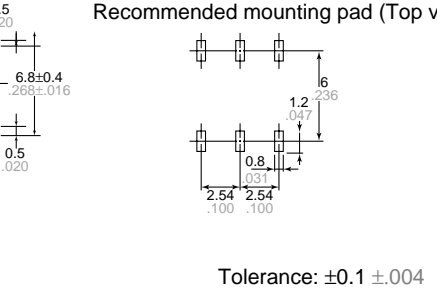
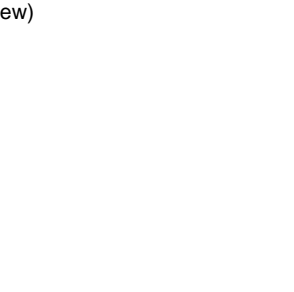
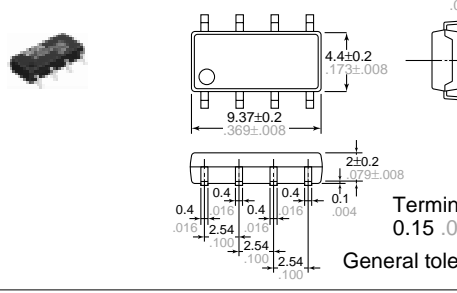
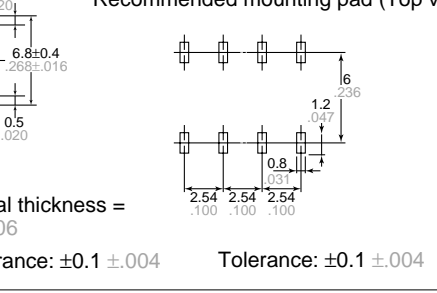
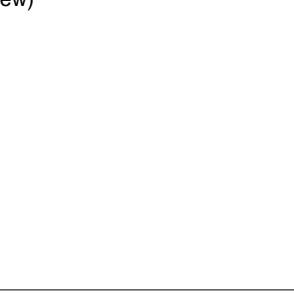
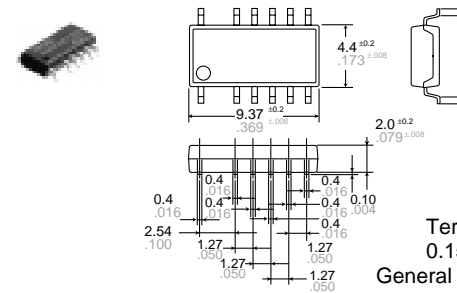
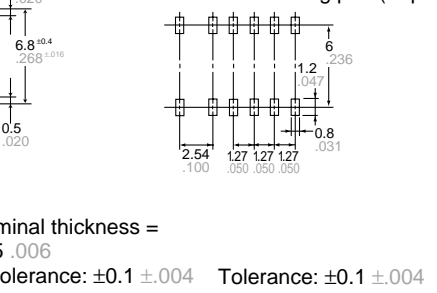
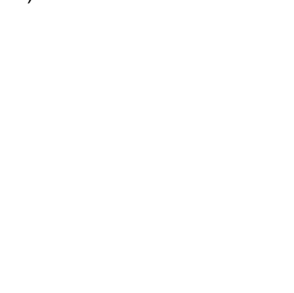

When turned off

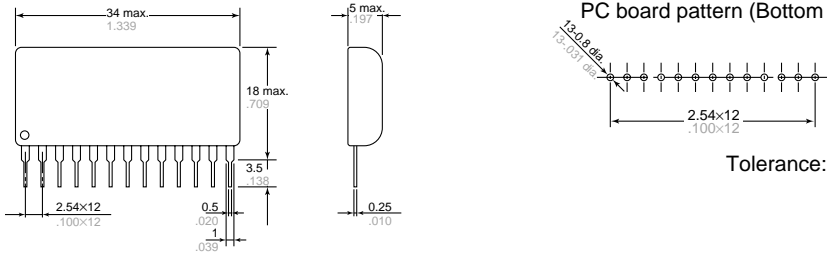

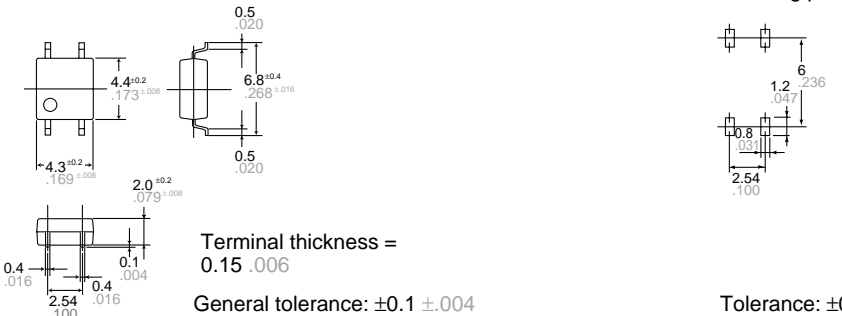
PhotoMOS Relay Dimensions

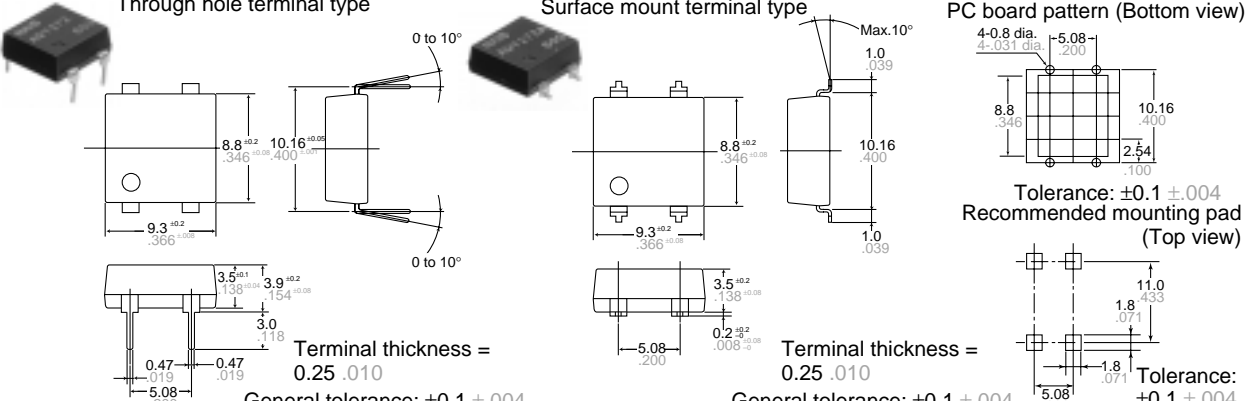
mm inch

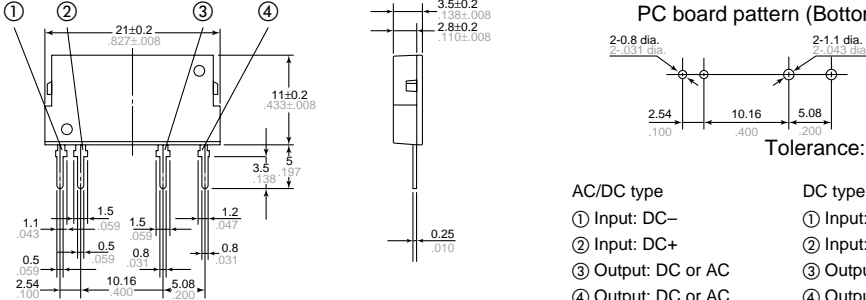
Type	Dimensions			
AQV10 AQV20 AQV21 AQV22 AQV23 AQV25 AQV41 AQV45 Series	Through hole terminal type  <p>Terminal thickness = 0.25 .010</p> <p>General tolerance: $\pm 0.1 \pm .004$</p>	Surface mount terminal type  <p>Terminal thickness = 0.25 .010</p> <p>General tolerance: $\pm 0.1 \pm .004$</p>	PC board pattern (Bottom view)  <p>Tolerance: $\pm 0.1 \pm .004$</p> <p>Recommended mounting pad (Top view) </p>	
AQW21 AQW22 AQW25 AQW41 AQW45 AQW61 AQW65 Series	Through hole terminal type  <p>Terminal thickness = 0.25 .010</p> <p>General tolerance: $\pm 0.1 \pm .004$</p>	Surface mount terminal type  <p>Terminal thickness = 0.25 .010</p> <p>General tolerance: $\pm 0.1 \pm .004$</p>	PC board pattern (Bottom view)  <p>Tolerance: $\pm 0.1 \pm .004$</p> <p>Recommended mounting pad (Top view) </p>	
Aqv21 (SOP) Aqv22 (SOP) Aqv41 (SOP) Series	 <p>Terminal thickness = 0.25 .010</p> <p>General tolerance: $\pm 0.1 \pm .004$</p>	 <p>Terminal thickness = 0.25 .010</p> <p>General tolerance: $\pm 0.1 \pm .004$</p>	Recommended mounting pad (Top view)  <p>Tolerance: $\pm 0.1 \pm .004$</p>	
Aqw21(SOP) Aqw21OTS (SOP) Series	 <p>Terminal thickness = 0.15 .006</p> <p>General tolerance: $\pm 0.1 \pm .004$</p>	 <p>Terminal thickness = 0.15 .006</p> <p>General tolerance: $\pm 0.1 \pm .004$</p>	Recommended mounting pad (Top view)  <p>Tolerance: $\pm 0.1 \pm .004$</p>	
Aqw21OT2S (SOP) Series	 <p>Terminal thickness = 0.15 .006</p> <p>General tolerance: $\pm 0.1 \pm .004$</p>	 <p>Terminal thickness = 0.15 .006</p> <p>General tolerance: $\pm 0.1 \pm .004$</p>	Recommended mounting pad (Top view)  <p>Tolerance: $\pm 0.1 \pm .004$</p>	

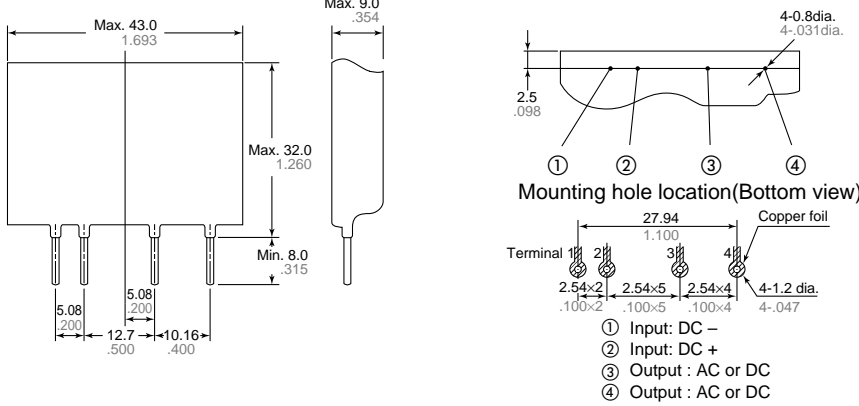
Type	Dimensions	
<p>AQX21•44 Series (Multi-channel type)</p> 	 <p>PC board pattern (Bottom view)</p> <p>Tolerance: $\pm 0.1 \pm 0.004$</p> <p>General tolerance: $\pm 0.5 \pm 0.020$</p>	
<p>AQY21 (SOP) AQY41 (SOP) Series</p> 	 <p>Recommended mounting pad (Top view)</p> <p>Terminal thickness = 0.15 ± 0.006</p> <p>General tolerance: $\pm 0.1 \pm 0.004$</p> <p>Tolerance: $\pm 0.1 \pm 0.004$</p>	
<p>AQY27 Series</p> 	 <p>Through hole terminal type</p> <p>Surface mount terminal type</p> <p>PC board pattern (Bottom view)</p> <p>Recommended mounting pad (Top view)</p> <p>Terminal thickness = 0.25 ± 0.010</p> <p>Terminal thickness = 0.25 ± 0.010</p> <p>Terminal thickness = 0.25 ± 0.010</p> <p>General tolerance: $\pm 0.1 \pm 0.004$</p> <p>General tolerance: $\pm 0.1 \pm 0.004$</p> <p>General tolerance: $\pm 0.1 \pm 0.004$</p> <p>Tolerance: $\pm 0.1 \pm 0.004$</p>	
<p>AQZ10 AQZ20 Series</p> 	 <p>PC board pattern (Bottom view)</p> <p>AC/DC type</p> <p>DC type</p> <p>① Input: DC- ① Input: DC-</p> <p>② Input: DC+ ② Input: DC+</p> <p>③ Output: DC or AC ③ Output: DC-</p> <p>④ Output: DC or AC ④ Output: DC+</p> <p>General tolerance: $\pm 0.1 \pm 0.004$</p> <p>Tolerance: $\pm 0.1 \pm 0.004$</p>	
<p>AQZ26 Series</p> 	 <p>Mounting hole location (Bottom view)</p> <p>① Input: DC -</p> <p>② Input: DC +</p> <p>③ Output : AC or DC</p> <p>④ Output : AC or DC</p> <p>General tolerance $\pm 0.5 \pm 0.020$</p> <p>Pitch tolerance: $\pm 0.1 \pm 0.004$</p>	

Terminology

	Term	Symbol	Description
Input	LED forward current	I_F	Current that flows between the input terminals when the input diode is forward biased.
	LED reverse voltage	V_R	Reverse breakdown voltage between the input terminals.
	Peak forward current	I_{FP}	Maximum instantaneous value of the forward current.
	LED operate current	I_{FON}	Current when the output switches on (by increasing the LED current) with a designated supply voltage and load connected between the output terminals.
	LED turn off current	I_{Foff}	Current when the output switches off (by decreasing the LED current) after operating the relay with a designated supply voltage and load connected between the output terminals.
	LED dropout voltage	V_F	Dropout voltage between the input terminals due to forward current.
	Power dissipation	P_{in}	Allowable power dissipation between the input terminals.
Output	Load voltage	V_L	Supply voltage range at the output used to normally operate the PhotoMOS relay. Represents the peak value for AC voltages.
	Continuous load current	I_L	Maximum current value that flows continuously between the output terminals of the PhotoMOS relay under designated ambient temperature conditions. Represents the peak value for AC current.
	On resistance	R_{on}	Obtained using the equation below from dropout voltage V_{DS} (on) between the output terminals (when a designated LED current is made to flow through the input terminals and the designated load current through the output terminals.) $R_{on} = V_{DS} (on)/I_L$
	Off state leakage current	I_{leak}	Current flowing to the output when a designated supply voltage is applied between the output terminals with no LED current flow.
	Power dissipation	P_{out}	Allowable power dissipation between the output terminals.
Electrical characteristics	Turn on time	T_{on}	Delay time until the output switches on after a designated LED current is made to flow through the input terminals.
	Turn off time	T_{off}	Delay time until the output switches off after the designated LED current flowing through the input terminals is cut off.
	I/O capacitance	C_{iso}	Capacitance between the input and output terminals.
	Output capacitance	C_{out}	Capacitance between output terminals when LED current does not flow.
	I/O isolation resistance	R_{iso}	Resistance between terminals (input and output) when a specified voltage is applied between the input and output terminals.
	Total power dissipation	P_T	Allowable power dissipation in the entire circuit between the input and output terminals.
	I/O isolation voltage	V_{iso}	Critical value before dielectric breakdown occurs, when a high voltage is applied for 1 minute between the same terminals where the I/O isolation resistance is measured.
	Operating temperature	T_{opr}	Ambient temperature range in which the PhotoMOS relay can operate normally with a designated load current conditions.
	Storage temperature	T_{stg}	Ambient temperature range in which the PhotoMOS relay can be stored without applying voltage.

Reliability tests

Classification	Item	Condition	Purpose
Life tests	High temperature storage test	T_{stg} (Max.)	Determines resistance to long term storage at high temperature.
	Low temperature storage test	T_{stg} (Min.)	Determines resistance to long term storage at low temperature.
	High temperature and high humidity storage test	85°C 185°F, R.H. 85%	Determines resistance to long term storage at high temperature and high humidity.
	Continuous operation life test	$V_L = \text{Max.}$, $I_L = \text{Max.}$, $I_F = \text{LED operate current (Max.)}$	Determines resistance to electrical stress (voltage and current).
Thermal environment tests	Temperature cycling test	Low storage temperature (T_{stg} Min.) High storage temperature (T_{stg} Max.)	Determines resistance to exposure to both low temperatures and high temperatures.
	Thermal shock test	Low temperature (0°C) (32°F), High temperature (100°C) (212°F)	Determines resistance to exposure to sudden changes in temperature.
	Solder burning resistance	260±5°C 500±41°F, 10 s	Determines resistance to thermal stress occurring while soldering.
Mechanical environment tests	Vibration test	196 m/s ² {20 G}, 20 to 2,000 Hz*1	Determines the resistance to vibration sustained during shipment or operation.
	Shock test	9,800 m/s ² {1,000 G} 0.5 ms*2; 4,900 m/s ² {500 G} 1 ms	Determines the mechanical and structural resistance to shock.
	Drop test	Dropped at a height of 80 cm on oak board	Determines the mechanical resistance to drops sustained during shipment or operation.
	Terminal strength test	Determined from terminal shape and cross section	Determines the resistance to external force on the terminals of the PhotoMOS relay mounted on the PC board while wiring or operating.
	Solderability	230°C 446°F 5 s (with soldering flux)	Evaluates the solderability of the terminals.

*1 10 to 55 Hz at double amplitude of 3 mm for Power PhotoMOS relays.

*2 4,900 m/s², 1 ms for Power PhotoMOS relays.

PhotoMOS Relay Schematic and Wiring Diagrams

Type	Schematic	Output configuration	Load	Con-nection	Wiring diagram
AQV21 AQV21 (SOP) AQV22 AQV22 (SOP) AQV23 AQV25 Series		1a	AC/DC	A	
			DC	B*	
			DC		
(AQV254R only)		DC	C		
AQW21 AQW21 (SOP) AQW22 AQW25 Series		2a	AC/DC	—	(1) Two independent 1 Form A use (2) 2 Form A use
AQW21OTS Series	<p>Relay portion (1,2,7,8 pins) Detector portion (3,4,5,6 pins)</p>	Relay portion 1a Detector portion 1a	Relay portion AC/DC Detector portion DC	—	
AQW21OTS2S Series	<p>Relay portion (1,2,11,12 pins) Detector portion (3,4,9,10 pins) (5,6,7,8 pins)</p>	Relay portion 1a Detector portion 2a	Relay portion AC/DC Detector portion DC	—	

*Can be also connected as 2 Form A type. (However, the sum of the continuous load current should not exceed the absolute maximum rating.)
 **Can be also connected as 2 Form B type. (However, the sum of the continuous load current should not exceed the absolute maximum rating.)
 Notes: 1. E₁: Power source at input side; V_{IN}: Input voltage; I_F: LED forward current; V_L: Load voltage; I_L: Load current; R: Current limit resistor.
 2. Method of connecting the load at the output is divided into 3 types.

Type	Schematic	Output configuration	Load	Con- nection	Wiring diagram
AQV41 AQV41 (SOP) AQV45 Series		1b	AC/DC	A	
			DC	B**	
DC	C				
AQW61 AQW65 Series		1a1b	AC/DC	—	<p>(1) Two independent 1 Form A & 1 Form B use</p>
					<p>(2) 1 Form A 1 Form B use</p>
AQW41 AQW45 Series		2b	AC/DC	—	<p>(1) Two independent 1 Form B use</p>
					<p>(2) 2 Form B use</p>
AQV10 Series	<p>Terminal 3 cannot be used, since it is in the internal circuit of the relay.</p>	1a	DC	A	

*Can be also connected as 2 Form A type. (However, the sum of the continuous load current should not exceed the absolute maximum rating.)

**Can be also connected as 2 Form B type. (However, the sum of the continuous load current should not exceed the absolute maximum rating.)

Notes: 1. E_1 : Power source at input side; V_{IN} : Input voltage; I_F : LED forward current; V_L : Load voltage; I_L : Load current; R: Current limit resistor.

2. Method of connecting the load at the output is divided into 3 types.

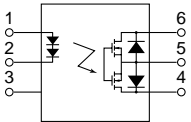
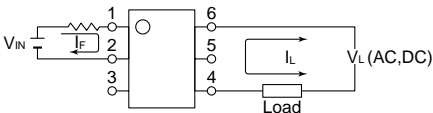
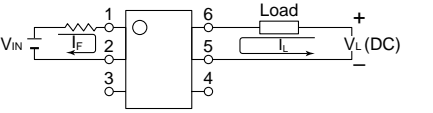
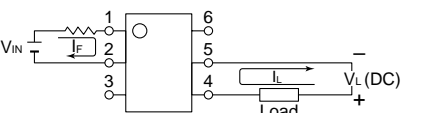
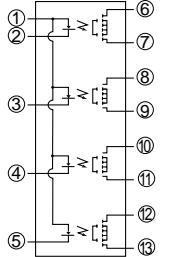
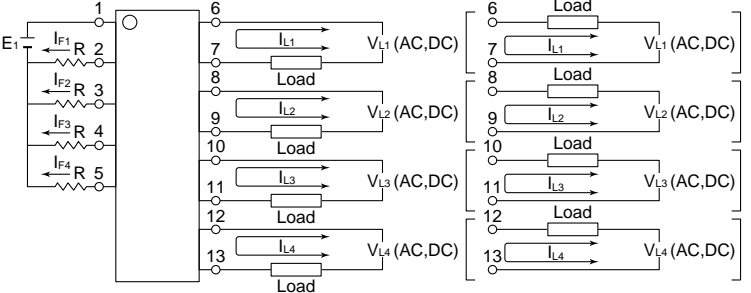
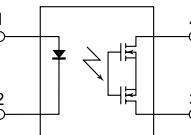
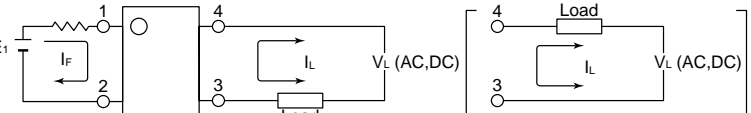
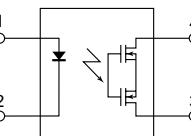
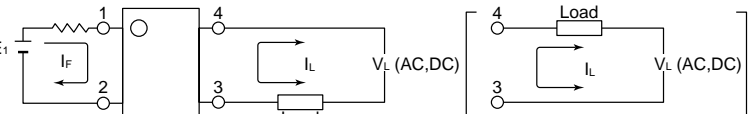
Type	Schematic	Output configuration	Load	Con- nection	Wiring diagram
AQV20 Series		1a	AC/DC	A	
			DC	B*	
			DC	C	
	Terminal 3 cannot be used, since it is in the internal circuit of the relay.				
AQX21-44 Series (Multi-channel type)	 <p> ① Input Common: DC+ ② Input 1: DC- ③ Input 2: DC- ④ Input 3: DC- ⑤ Input 4: DC- ⑥ Output 1 (N.O.): DC or AC ⑦ Output 2 (N.O.): DC or AC ⑧ Output 2 (N.O.): DC or AC ⑨ Output 2 (N.O.): DC or AC ⑩ Output 3 (N.O.): DC or AC ⑪ Output 3 (N.O.): DC or AC ⑫ Output 4 (N.O.): DC or AC ⑬ Output 4 (N.O.): DC or AC </p>	4a	AC/DC	-	
AQY21 (SOP) AQY27 Series		1a	AC/DC	-	
AQY41 (SOP) Series		1b	AC/DC	-	

*Can be also connected as 2 Form A type. (However, the sum of the continuous load current should not exceed the absolute maximum rating.)
 **Can be also connected as 2 Form B type. (However, the sum of the continuous load current should not exceed the absolute maximum rating.)
 Notes: 1. E_1 : Power source at input side; V_{IN} : Input voltage; I_F : LED forward current; V_L : Load voltage; I_L : Load current; R : Current limit resistor.
 2. Method of connecting the load at the output is divided into 3 types.

Type	Schematic	Output configuration	Load	Wiring diagram
AQZ20 Series		1a	AC/DC	
AQZ10 Series		1a	DC	
AQZ20-V Series		1a	AC/DC	
AQZ20-D Series		1a	AC/DC	
AQZ10-D Series		1a	DC	
AQZ26 Series		1a	AC/DC	

Notes: 1. E_1 : Power source at input side; V_{IN} : Input voltage; I_F : LED forward current; V_L : Load voltage; I_L : Load current; R : Current limit resistor.
2. Method of connecting the load at the output is divided into 3 types.

PhotoMOS Relay Cautions for Use

SAFETY WARNINGS

• Do not use the product under conditions that exceed the range of its specifications. It may cause overheating, smoke, or fire.

• Do not touch the recharging unit while the power is on. There is a danger of electrical shock. Be sure to turn off the power when performing mounting, maintenance, or repair operations on the relay (including connecting parts such as the terminal board and socket).

• Check the connection diagrams in the catalog and be sure to connect the terminals correctly. Erroneous connections could lead to unexpected operating errors, overheating, or fire.

NOTES

■ PhotoMOS Relays excluding Power PhotoMOS Relays

1. Unused terminals

The No. 3 terminal is used with the circuit inside the relay. Therefore, do not connect it to the external circuitry with either connection method A, B or C.

2. Short across terminals

Do not short circuit between terminals when relay is energized, since there is the possibility of breaking the internal IC.

3. Surge voltages at the input

If reverse surge voltages are present at the input terminals, connect a diode in reverse parallel across the input terminals and keep the reverse voltages below the reverse breakdown voltage.

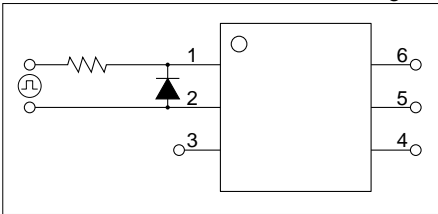

4. Recommended LED forward current (I_F)

It is recommended that the LED forward current (I_F) of each PhotoMOS Relay should be set according to the following table.

Type	Product name	Recommended LED forward current (I _F)
DIP SMD type	AQV10,20 Series	10 mA
	AQY27 Series*	5 to 10 mA
	AQV21 Series (including SOP)	5 mA
	AQV22 Series (including SOP)	
	AQV25 Series	
	AQV45 Series	
	AQW21 Series (including SOP)	
	AQW21 ○TS, T2S Series	
	AQW41 Series	
	AQW61 Series	
	AQW22 Series	
	AQW25 Series	
	AQW45 Series	
AQW65 Series		
AQY21,41 Series		
AQV23 Series	2 mA	
Reinforced I/O isolation (5,000 V AC)	AQV21,41 Series	5 to 10 mA
	AQV25,45 Series	
SIL type	AQX21 Series	5 mA
	AQZ10,20,26 Series	5 to 10 mA

*Standard I/O insulation type (2,500 V AC)

5. Ripple in the input power supply

If ripple is present in the input power supply, observe the following:

- 1) For LED operate current at E_{min}, maintain the value mentioned in the table of "Note 4. Recommended LED forward current (I_F)."
- 2) Keep the LED operate current at 50 VmA (25 mA for PhotoMOS HE Relay with LED display type) or less at E_{max}.

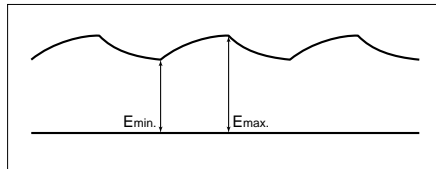

6. Output spike voltages

1) If an inductive load generates spike voltages which exceed the absolute maximum rating, the spike voltage must be limited.

Typical circuits are shown below.

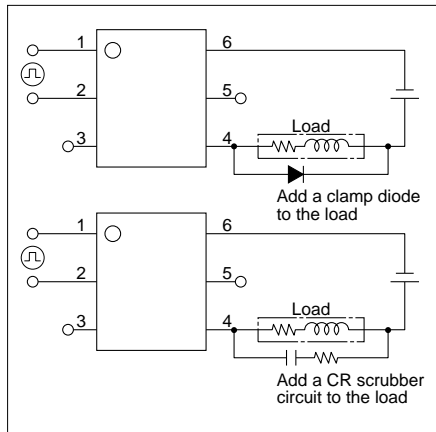

2) Even if spike voltages generated at the load are limited with a clamp diode if the circuit wires are long, spike voltages will occur by inductance. Keep wires as short as possible to minimize inductance.

7. Cleaning solvents compatibility

Dip cleaning with an organic solvent is recommended for removal of solder flux, dust, etc. Select a cleaning solvent from the following table. If ultrasonic cleaning must be used, the severity of factors such as frequency, output power and cleaning solvent selected may cause loose wires and other defects. Make sure these conditions are correct before use. For details, please consult us.

Cleaning solvent		Compatibility (○: Yes ×: No)
Chlorine-base	• I.I.I. Trichloroethylene (Chloroethylene)	○
	• Trichloroethylene (Trichlene)	
	• Perchloroethylene	
	• Methlene chloride	
Adueous	• Indusco 624, 1000	○
	• Hollis 310	
	• Lonco Terg	
Alcohol-base	• IPA • Ethanol	○
Others	• Thinner • Gasoline	×

8. INPUT WIRING PATTERN

With AQY or AQW types, avoid installing the input (LED side) wiring pattern to the bottom side of the package if you require the specified I/O isolation voltage (V_{iso}) after mounting the PC board. Since part of the frame on the output side is exposed, it may cause fluctuations in the I/O isolation voltage.

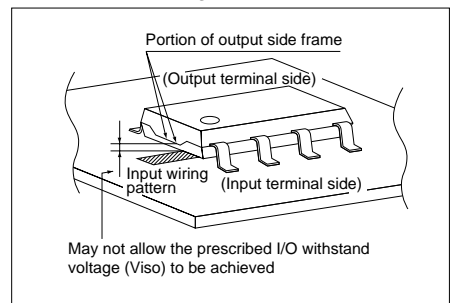

9. Soldering

- When soldering PC board terminals, keep soldering time to within 10 s at 260°C 500°F.
- When soldering surface-mount terminals, the following conditions are recommended.

(1) IR (Infrared reflow) soldering method

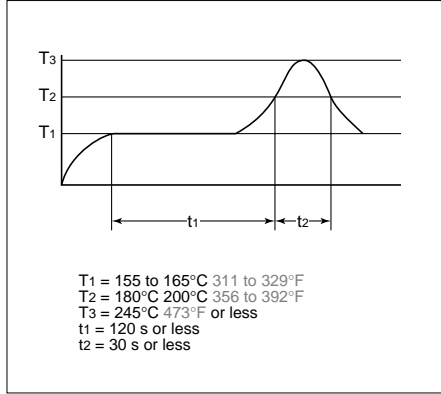

(2) Vapor phase soldering method

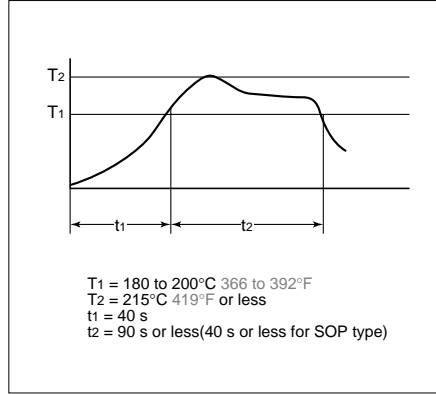

(3) Double wave soldering method

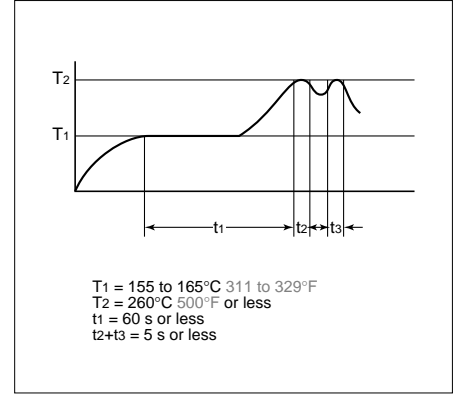

(4) Soldering iron method

Tip temperature: 280 to 300°C 536 to 572°F

Wattage: 30 to 60 W

Soldering time: within 5 s

(5) Others

Check mounting conditions before using other soldering methods (hot-air, hot plate, pulse heater, etc.)

- The temperature profile indicates the temperature of the soldered terminal on the surface of the PC board. The

ambient temperature may increase excessively. Check the temperature under mounting conditions.

- The conditions for the infrared reflow soldering apply when preheating using the VPS method.

10. The following shows the packaging format

1) Tape and reel

mm inch

Type	Tape dimensions	Dimensions of paper tape reel
SO package 4-pin type	<p>(1) When picked from 1/2-pin side: Part No. AQY○○SX (Reel color: blue) (Shown above) (2) When picked from 3/4-pin side: Part No. AQY○○SZ (Reel color: orange)</p>	
SO package 6-pin type	<p>(1) When picked from 1/2/3-pin side: Part No. AQV○○SX (Reel color: blue) (Shown above) (2) When picked from 4/5/6-pin side: Part No. AQV○○SZ (Reel color: orange)</p>	
SO package 8-pin type	<p>(1) When picked from 1/2/3/4-pin side: Part No. AQW○○SX (Shown above) (2) When picked from 5/6/7/8-pin side: Part No. AQW○○SZ</p>	
SO package 12-pin type	<p>(1) When picked from 1/2/3/4/5/6-pin side: Part No. AQW○○T2SX (Shown above) (2) When picked from 7/8/9/10/11/12-pin side: Part No. AQW○○T2SZ</p>	

Type	Tape dimensions	Dimensions of paper tape reel
<p>PD 4-pin SMD type</p> <p>(1) When picked from 1/2-pin side: Part No. AQY○○○AX (Shown above) (2) When picked from 3/4-pin side: Part No. AQY○○○AZ</p>	<p>(1) When picked from 1/2/3-pin side: Part No. AQV○○○AX (Shown above) (2) When picked from 4/5/6-pin side: Part No. AQV○○○AZ</p>	<p>(1) When picked from 1/2/3/4-pin side: Part No. AQW○○○AX (Shown above) (2) When picked from 5/6/7/8-pin side: Part No. AQW○○○AZ</p>

2) Tube

(1) Devices are packaged in a tube so pin No. 1 is on the stopper B side. Observe correct orientation when mounting them on PC boards.

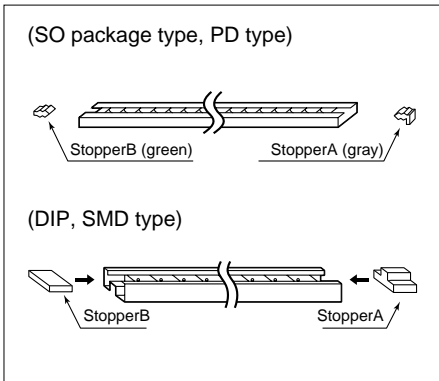

(2) Storage

PhotoMOS relays implemented in SO packages are sensitive to moisture and come in sealed moisture-proof packages. Observe the following cautions on storage.

- After the moisture-proof package is unsealed, take the devices out of storage as soon as possible (within 1 month at the most).
- If the devices are to be left in storage for a considerable period after the moisture-proof package has been unsealed, it is recommended to keep them in another moisture-proof bag containing silica gel (within 3 months at

the most).

11. Transportation and storage

- 1) Extreme vibration during transport will warp the lead or damage the relay. Handle the outer and inner boxes with care.
- 2) Storage under extreme conditions will cause soldering degradation, external appearance defects, and deterioration of the characteristics. The following storage conditions are recommended:
 - Temperature: 5 to 30°C 41 to 86°F
 - Humidity: Less than 60% R.H.
 - Atmosphere: No harmful gasses such as sulfurous acid gas, minimal dust.

■ Power PhotoMOS Relays

1.-1) Input LED current (Standard type and Internal varistor type)

For rising and dropping ratio of input LED current (di/dt), maintain min. 100 μA/s.

1.-2) Input voltage (Voltage sensitive type)

For rising and dropping ratio of input voltage (dv/dt), maintain min. 100 mV/s.

2. Short across terminals

Do not short circuit between terminals when relay is energized, since there is possibility of breaking of the internal IC.

3. Surge voltages at the input

If reverse surge voltages are present at the input terminals, connect a diode in reverse parallel across the input terminals and keep the reverse voltages be low the reverse breakdown voltage.

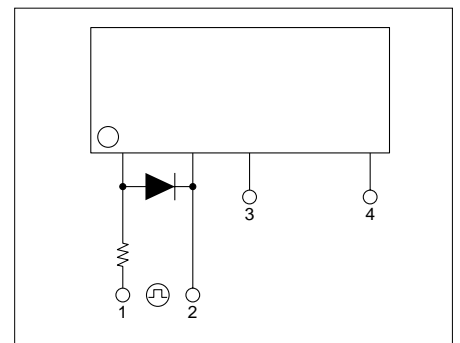

4. Recommended load voltage

As a guide in selecting PhotoMOS Relays, please refer to the following table.

1) Power photoMOS relays

Type		Absolute maximum rating		Recommended load voltage
		Load voltage	Load current	
AC/DC type	AQZ202	Peak AC 60 V	Peak AC 3.0 A	12 V AC; 5, 12,24 V DC
	AQZ205	Peak AC 100 V	Peak AC 2.0 A	24 V AC 48 V DC
	AQZ207	Peak AC 200 V	Peak AC 1.0 A	48 V AC 100 V DC
	AQZ204	Peak AC 400 V	Peak AC 0.5 A	100 V AC 200 V DC
DC type	AQZ102	60 V DC	4.0 A DC	5,12,24 V DC
	AQZ105	100 V DC	2.6 A DC	48 V DC
	AQZ107	200 V DC	1.3 A DC	100 V DC
	AQZ104	400 V DC	0.7 A DC	200 V DC

2) Power PhotoMOS relay high capacity type

Type		Absolute maximum rating		Recommended load voltage
		Load voltage	Load current	
AC/DC type	AQZ262	Peak AC, DC 60V	Peak AC, DC 6A	12V AC 5,12,24V DC
	AQZ264	Peak AC, DC 400V	Peak AC, DC 1A	AC100V DC200V

3) Power photoMOS relays (Voltage sensitive type)

Type		Absolute maximum rating		Recommended load voltage
		Load voltage	Load current	
AC/DC type	AQZ202D	Peak AC 60 V	Peak AC 2.7 A	12 V AC; 5, 12,24 V DC
	AQZ205D	Peak AC 100 V	Peak AC 1.8 A	24 V AC 48 V DC
	AQZ207D	Peak AC 200 V	Peak AC 0.9 A	48 V AC 100 V DC
	AQZ204D	Peak AC 400 V	Peak AC 0.45 A	100 V AC 200 V DC
DC type	AQZ102D	60 V DC	3.6 A DC	5,12,24 V DC
	AQZ105D	100 V DC	2.3 A DC	48 V DC
	AQZ107D	200 V DC	1.1 A DC	100 V DC
	AQZ104D	400 V DC	0.6 A DC	200 V DC

4) Power photoMOS relays with internal varistor type

Type		Absolute maximum rating		Recommended load voltage
		Load voltage	Load current	
AC/DC type	AQZ202V	17 V AC 22 V DC	Peak AC 3.0 A	12 V AC; 5,12 V DC
	AQZ205V	30 V AC 38 V DC	Peak AC 2.0 A	24 V AC 48 V DC
	AQZ207V	60 V AC 85 V DC	Peak AC 1.0 A	48 V AC 100 V DC
	AQZ204V	140 V AC 180 V DC	Peak AC 0.5 A	100 V AC 200 V DC

5.-1) Ripple in the input power supply (Standard type and high capacity type and internal varistor type)

If ripple is present in the input power supply, observe the following:

1) For LED operate current at E_{min} , maintain min. 5 mA

2) Keep the LED operate current at 50 mA or less at E_{max} .

5.-2) Ripple in the input power supply (Voltage sensitive type)

If ripple is present in the input power supply, observe the following:

1) For input voltage at E_{min} , maintain min. 4 V

2) Keep input voltage at 30 V or less at E_{max} .

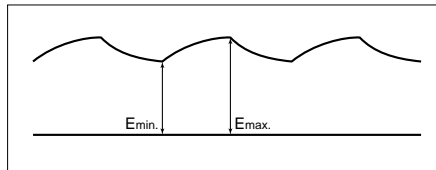

6. Output spike voltages

1) If an inductive load generates spike voltages which exceed the absolute maximum rating, the spike voltage must be limited.

Typical circuits are shown below.

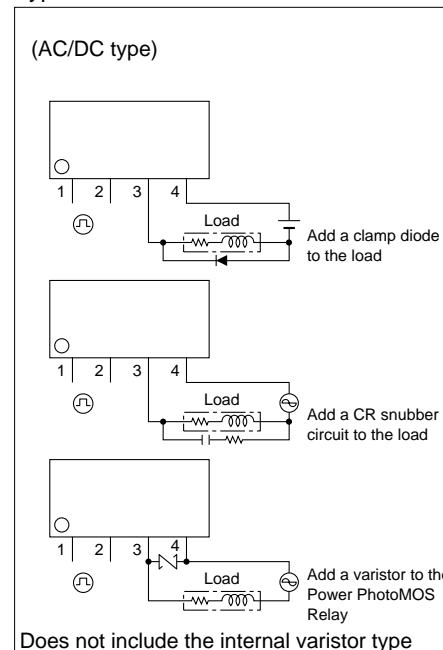

2) Even if spike voltages generated at the load are limited with a clamp diode if the circuit wires are long, spike voltages will occur by inductance. Keep wires as short as possible to minimize inductance.

7. Adjacent mounting

1) When relays are mounted close together with the heat-generated devices, ambient temperature may rise abnormally. Mounting layout and ventilation should be considered.

2) When many relays are mounted close together, load current should be reduced. (Refer to the date of "Load current vs. ambient temperature characteristics in adjacent mounting.")

8. Cleaning solvents compatibility

Dip cleaning with an organic solvent is recommended for removal of solder flux, dust, etc. Select a cleaning solvent from the following table. If ultrasonic cleaning must be used, the severity of factors such as frequency, output power and cleaning solvent selected may cause loose wires and other defects. Make sure these conditions are correct before use. For details, please consult us.

Cleaning solvent		Compatibility (○: Yes ×: No)
Chlorine-base	• I.I.I. Trichloroethylene (Chloroethylene)	○
	• Trichloroethylene (Trichlene)	
	• Perchloroethylene	
	• Methylene chloride	
Aqueous	• Indusco 624, 1000	○
	• Hollis 310	
Alcohol-base	• IPA	○
	• Ethanol	
Others	• Thinner	×
	• Gasoline	

9. Soldering

When soldering PC board terminals, keep soldering time to within 10 s at 260°C 500°F.

10. Packing style

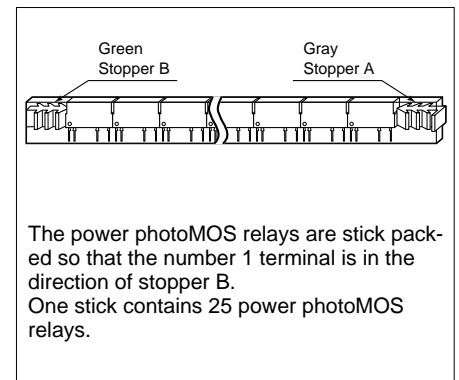

11. Transport and storage

1) If the product is subject to extreme vibration during transport, the lead may warp or the main unit may become damaged. Handle the outer and inner boxes with care.

2) If the storage environment is extremely bad, it may give rise to deterioration of the soldering, external appearance defects, and degradation the characteristics of the product. The following conditions are recommended for the storage location:

- Temperature: 5 to 30°C 41 to 86°F
- Humidity: Less than 60% RH
- Environment: No hazardous substances such as sulfurous acid gases, and little dust.

PhotoMOS Relays for Various Applications



Automatic meter reading

The needs of centralized remote meter reading systems for water, gas and electricity in medium and high rise apartments and new subdivisions are now increasing. PhotoMOS relays are capable of controlling from low level signals up to power signals and feature low leakage current and noise from the optoelectronic device and power MOSFET combination.

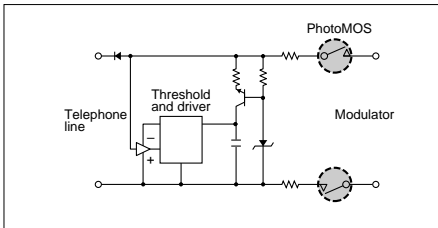

Telecommunications

A variety of signals, with levels from millivolts (at microamperes) to tens of volts (at several hundred milliamperes), AC or DC, and even high bit-rate signals, can be superimposed on telephone lines, the heart of telecommunication networks. The switches in telecommunication circuits, which normally carry DC signals, also carry AC signals on top of the DC level when an intermittent signal (e.g. ringer signal) is being sent. PhotoMOS relays are capable of controlling small level (millivolts at microamperes) AC or DC signals.

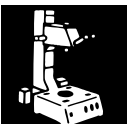
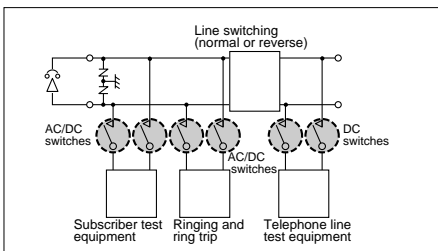

Instrumentation

With the spread of microcomputer chips, the latest instruments are required to measure a variety of signals at high speeds under various conditions. PhotoMOS relays are recommended for measurement scanning functions, automatic zero-point compensation to eliminate zero-point error, and measurement sequence interfaces (e.g. alarm interface.)

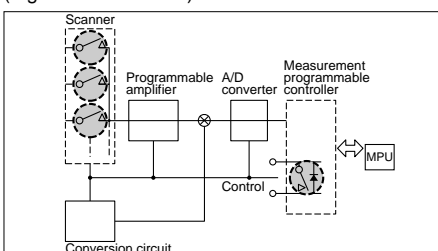

Medical equipment

Medical equipment which processes low level signals includes electrocardiographs, electroencephalographs, and X-ray CT scanners. PhotoMOS relays accurately transfer low level signals (less than several hundred millivolts). Furthermore, they are also convenient in driving rotary solenoids such as those used to automatically switch voltage ranges.

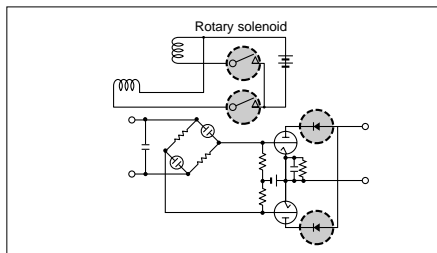

Communications equipment

The future of communications is in satellite communications. Satellite-communications feature many advantages such as indifference to terrestrial disasters, wide service areas, simple circuit modification and simultaneous conversations. An important control operation in communications equipment is fast automatic tuning. PhotoMOS relays can easily be connected in parallel, difficult with conventional transistor type. As a result, a variety of circuit connection are possible and power circuits can also be designed.

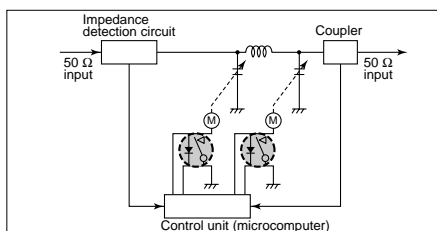

Programmable controller

The output circuit of a programmable controller requires various interfaces to match the load type. Recently, as the computing speed and data processing speed increase, problems may arise from noise at the input interface as well as at the output interface. PhotoMOS relays are resistant to inrush current (due to phase shift) and eliminate the need for snubber circuits as long as they are operated within the ratings. Furthermore, use of PhotoMOS relays decreases the mounting area requirements, resulting in more compact programmable controllers.

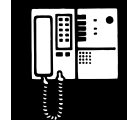
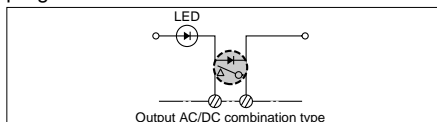

Security Equipment

There are many types of security systems from home and office security to building security. PhotoMOS relays are ideal for use as input interfaces for system sensors and output interfaces for alarms. Input interface: Low leakage current makes use possible for low level voltage and current input. Output interface: Outputs either AC or DC up to a load voltage of 400 V.

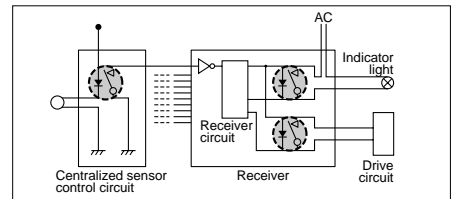

OA equipment

OA equipment usually contains a sensor control unit (for temperature, speed, torque, etc.), drive unit, power supply unit, and a processing unit which controls the overall system. It is organized similarly to compact factory automation machinery. PhotoMOS relays have wide application in the interfaces for signals which connect the functions of these units.

- Operates on a 24 mW input to enable direct control of C-MOS devices.
- Signal transfer through optical coupling achieves high resistance to noise and transients, eliminating the need for adding a snubber circuit to the output to control the load voltage.
- Advantages in the total cost and reliability in the control system result from the absence of AC leakage current related to the snubber circuit.

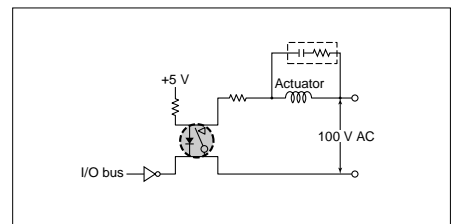

If you are a user experiencing difficulty with solid-state relays and triacs:

- | | | |
|---|-------|--|
| <p>If you would like to control small analog signals with a photocoupler and solid-state relays.</p> | } ➔ { | <p>PhotoMOS relays feature low offset voltages and on resistances of 0.25 Ω or less. (AQV251 Connection)</p> |
| <p>If you require a device with a small leakage current (as opposed to bipolar devices having large internal leakage currents).</p> | } ➔ { | <p>PhotoMOS relays have leakage currents in the order of microamperes and can control up to 1500 V (peak). (AQV258)</p> |
| <p>If you would like to directly control analog signals and you would like a device integrating a photocoupler, driver and analog IC to simplify the circuit as much as possible.</p> | } ➔ { | <p>PhotoMOS relays contain all of these functions in a single package. Furthermore, circuit design is simplified as a power supply is unnecessary since the internal optoelectronic device directly drives the power MOSFET.</p> |
| <p>If you require a snubber circuit with a triac or solid-state relay, but are concerned about the snubber circuit's AC leakage current.</p> | } ➔ { | <p>PhotoMOS relays are resistant to transients and as long as they are operated within the maximum ratings, eliminate the need for adding a snubber circuit to the output to control the rise in load voltage. Leakage current ceases to be a problem, with cost and reliability being other advantages.</p> |
| <p>If you require a device for AC control that is resistant to ambient temperature changes and input signal noise.</p> | } ➔ { | <p>PhotoMOS relays do not employ the self-trigger mechanism used in SCRs and triacs. Therefore, they do not switch on accidentally. Furthermore, the noise suppression characteristics of optoelectronic devices make them highly resistant to ambient noise for operation at temperatures up to 80°C 176°F.</p> |

PhotoMOS Relay Application Examples

High Response Speed

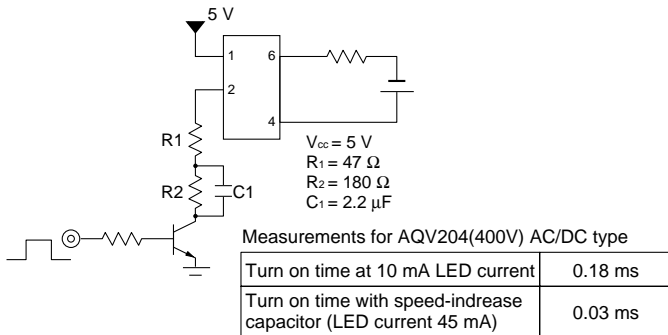

Microprocessor system I/O board

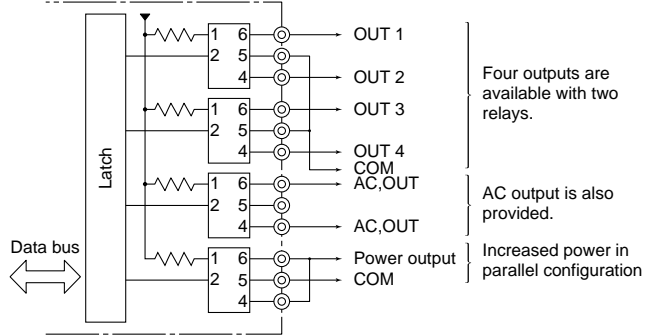

Dial Pulse Generator

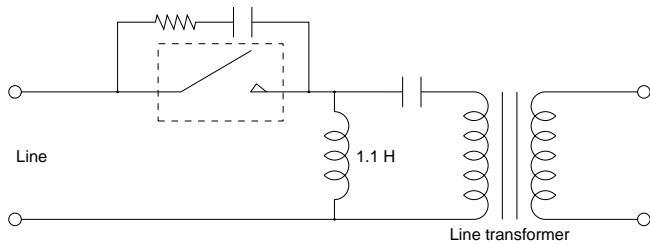

Capacitor Switch Circuit

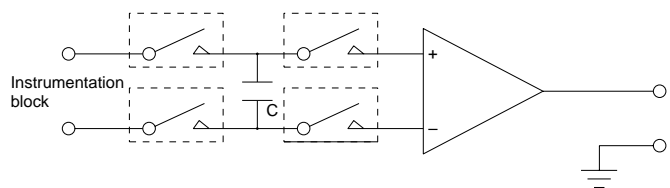

Scanner

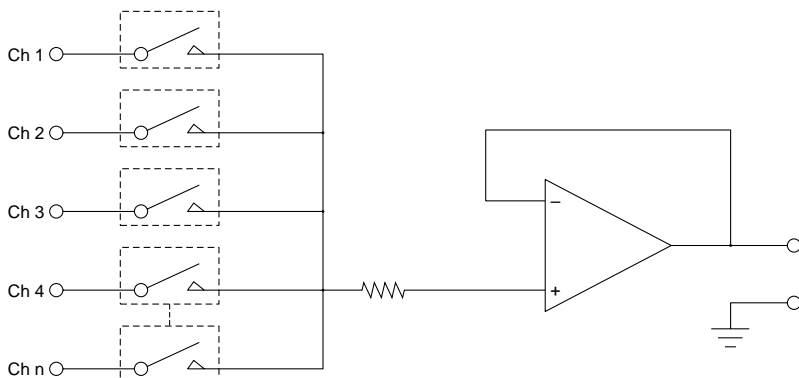

Part No. vs. Load Voltage Quick Reference

PhotoMOS Relays

Form A Type

Group name	Part No.	Package style	Number of channels	Load voltage	40 V	60 V	100 V (RF:80 V)	200 V	250 V	350 V	400 V	600 V	1000 V	1500 V
				Third digit	1	2	5	7	3	0	4	6	9	8
HE	AQV25○	DIP	1-channel	Standard Viso	AQV251	AQV252	AQV255	AQV257	AQV253		AQV254 AQV254R		AQV259	AQV258
	High Viso							AQV253H		AQV254H				
	AQW25○		2-channels	Standard Viso							AQW254			
HE Soft ON/OFF type	AQV25○M	DIP	1-channel	Standard Viso				AQV257M						
GU	AQV21○	DIP	1-channel	Standard Viso		AQV212	AQV215	AQV217		AQV210	AQV214	AQV216		
				High Viso							AQV214H			
	AQW21○		2-channels	Standard Viso		AQW212	AQW215	AQW217		AQW210	AQW214	AQW216		
	AQX2144○	SIL	4-channels	Standard Viso							AQX21444			
	AQY21○S	SOP	1-channel (4 pin)	Standard Viso						AQY210S	AQY214S			
	AQV21○S		1-channel (6 pin)	Standard Viso		AQV212S	AQV215S	AQV217S		AQV210S	AQV214S	AQV216S		
	AQW21○S		2-channels	Standard Viso						AQW210S	AQW214S			
AQW21○TS	SOP	2-channels (MOSFET+optocoupler)	Standard Viso							AQW210TS				
AQW21○T2S		3-channels (MOSFET+2optocouplers)	Standard Viso							AQW210T2S				
GU-E	AQV21○E	DIP	1-channel	Standard Viso						AQV210E	AQV214E			
				High Viso							AQV210EH	AQV214EH		
RF	AQV22○	DIP	1-channel	Standard Viso	AQV221		AQV225							
RF Low-ON type	AQV22○N	DIP	1-channel	Standard Viso			AQV225N	AQV227N			AQV224N			
				High Viso								AQV224N		
	AQW22○N		2-channels	Standard Viso			AQW225N	AQW227N			AQW224N			
	AQV22○NS	SOP	1-channel	Standard Viso			AQV225NS	AQV227NS			AQV224NS			
HS	AQV23○	DIP	1-channel	Standard Viso							AQV234			
HF	AQV10○	DIP	1-channel	Standard Viso	AQV101	AQV102				AQV103	AQV104			
				High Viso	AQV201	AQV202					AQV203	AQV204		
PD	AQY27○	DIP	1-channel	Standard Viso		AQY272	AQY275	AQY277			AQY274			

Form B Type

Group name	Part No.	Package style	Number of channels	Load voltage	300 V	400 V
				Third digit	3	4
HE	AQV45○	DIP	1-channel	Standard Viso	AQV453	AQV454
				High Viso		AQV454H
	AQW45○		2-channels	Standard Viso		AQW454
GU	AQV41○	DIP	1-channel	Standard Viso		AQV414
				High Viso		AQV414H
	AQY41○S	SOP	1-channel (4-pin)	Standard Viso		AQY414S
				High Viso		AQY414SH
AQV41○S	SOP	1-channel (6-pin)	Standard Viso		AQV414S	
			High Viso		AQV414SH	
GU-E	AQV41○E	DIP	1-channel	Standard Viso		AQV414E
				High Viso		AQV414EH

Form A Form B Type

Group name	Part No.	Package style	Number of channel	Load voltage	400 V
				Third digit	4
HE	AQW65○	DIP	2-channel	Standard Viso	AQW654
GU	AQW61○	DIP	2-channel	Standard Viso	AQW614

Power PhotoMOS Relays

Form A Type

Group name	Part No.	Package style	Number of channels	Load voltage	40 V	60 V	100 V	200 V	250 V	350 V	400 V
				Third digit	1	2	5	7	3	0	4
Standard type	AQZ10○	SIL	1-channel	Standard Viso		AQZ102	AQZ105	AQZ107			AQZ104
	AQZ20○					AQZ202	AQZ205	AQZ207			AQZ204
Varistor incorporated type	AQZ20○V					AQZ202V	AQZ205V	AQZ207V			AQZ204V
Voltage sensitive type	AQZ10○D					AQZ102D	AQZ105D	AQZ107D			AQZ104D
	AQZ20○D					AQZ202D	AQZ205D	AQZ207D			AQZ204D
High capacity type	AQZ26○							AQZ262			

○ stands for third digit.

Notes: 1. Standard Viso: 1,500 V between I/O. 2.High Viso: 5,000 V between I/O.