

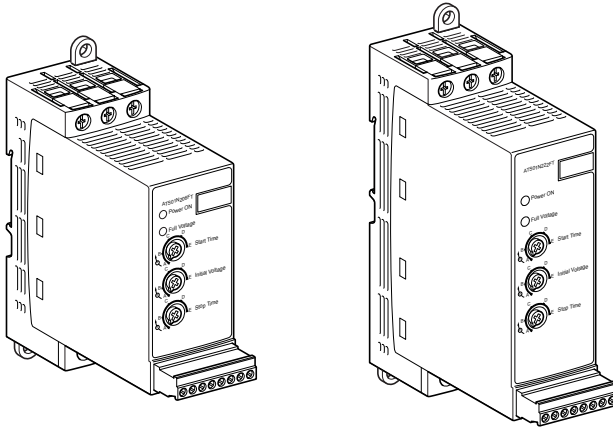

00162468613038

Altistart

ATS 01N2●●LU/QN/RT



⚠ ⚠ DANGER

HAZARD OF ELECTRIC SHOCK, EXPLOSION, OR ARC FLASH

- Only appropriately trained persons who are familiar with and understand the contents of this manual and all other pertinent product documentation and who have received safety training to recognize and avoid hazards involved are authorized to work on and with this soft starter system. Installation, adjustment, repair, and maintenance must be performed by qualified personnel.
- The system integrator is responsible for compliance with all local and national electrical code requirements as well as all other applicable regulations with respect to grounding of all equipment.
- Many components of the product, including the printed circuit boards, operate with mains voltage. Do not touch. Use only electrically insulated tools.
- Do not touch unshielded components or terminals with voltage present.
- AC voltage can couple voltage to unused conductors in the motor cable. Insulate both ends of unused conductors of the motor cable.
- Before performing work on the soft starter system:
 - Disconnect all power, including external control power that may be present.
 - Place a "Do Not Turn On" label on all power switches.
 - Lock all power switches in the open position.
- Install and close all covers before applying voltage.

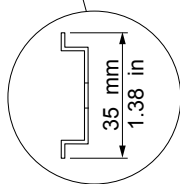
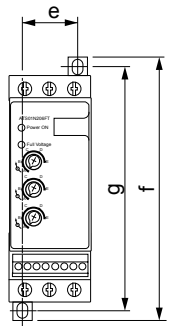
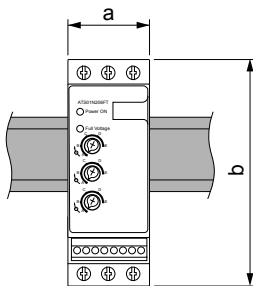
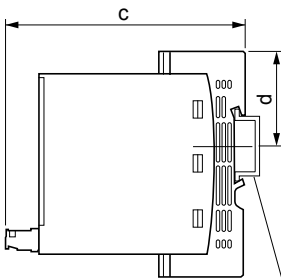

Failure to follow these instructions will result in death or serious injury.

Electrical equipment should be installed, operated, serviced, and maintained only by qualified personnel. No responsibility is assumed by Schneider Electric for any consequences arising out of the use of this product. © 2013 Schneider Electric. All Rights Reserved.

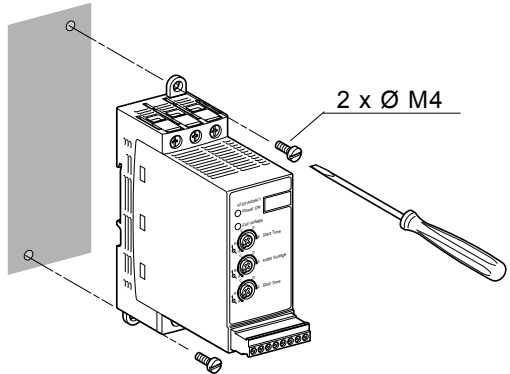
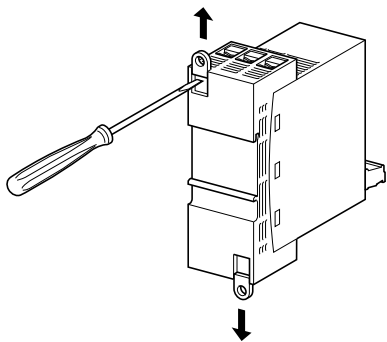

	a	b	c	d	e	f	g
	mm	mm	mm	mm	mm	mm	mm
	in	in	in	in	in	in	in
ATS 01N206●●	45	124	131	53	30	145	132
ATS 01N209●●	1.78	4.9	5.1	2.1	1.2	5.7	5.2
ATS 01N212●●							
ATS 01N222●●	45	154	131	72	30	175	162
ATS 01N232●●	1.78	6	5.1	2.8	1.2	6.9	6.4



				
	[mm ²]	AWG	Nm	lb/in
1/L1, 2/T1, 3/L2, 4/T2, 5/L3, 6/T3	10	8	1,9...2,5	17...22
R1A, R1C, COM, LI+, LI1, LI2, LO1, BOOST	2,5	14	0,5	4,5

	UL  CLASS J
ATS 01N206●●	20 A
ATS 01N209●●	30 A
ATS 01N212●●	35 A
ATS 01N222●●	80 A
ATS 01N232●●	100 A

	U1	
ATS 01N2●●LU	200 - 240 V	50 / 60 Hz
ATS 01N2●●QN	380 - 415 V	50 / 60 Hz
ATS 01N2●●RT	440 - 480 V	50 / 60 Hz

