24W
AC Adapter
SPECIFICATION

Model No. : **ATS024T-W120U (Level VI)**

Description : **12 Volts / 2.0 Amps**

Part No. : **ATS024TW120U415217**

Version : **A1**

Date : **02 – Dec. – 2017**

1. Feature :

- ◆ **Input** : **Universal 100 ~ 240 Vac / 50 - 60 Hz Input, without any slide switch.**
- ◆ **Output** : **12V / 0~2.0A**
- ◆ **Case Dimension** : **72mm(L)*34mm(W)*69mm(H) (±1mm)**
- ◆ **Efficiency** : **Eff (av) ≥ 86.204% Min.**
- ◆ **Safety** : **PSE**
- ◆ **EMI** : **Class B ; Conduction & Radiation Met.**
- ◆ **Protection** : **OVP (Over Voltage Protection) 、 SCP (Short Circuit Protection) 、 OCP (Over Current Protection)**
- ◆ **High frequency design , less power consumption.**
- ◆ **Suitable for usage at Telecommunication, Computer, Industrial Controller, & OA System.**
- ◆ **Meet DOE / Erp / GEMS.**

2. Input :

2.1 Voltage	Universal 100~240Vac, single phase
2.2 Frequency	50 - 60 Hz
2.3 Current	0.58A Max.
2.4 Inrush Current	50A Max. / 100Vac ; 60A Max. / 230Vac (Cold Start At 25 °C , Full Load)
2.5 Efficiency	Eff (av) ≥ 86.204% Min. (At 115 Vac & 230 Vac)
2.6 Power Consumption	Pi ≤ 0.1W (At 230Vac & No Load)

$$\text{※Eff (av)} = \frac{E_1 + E_2 + E_3 + E_4}{4}$$

E1=efficiency with 25% rated load ; E2= efficiency with 50% rated load
E3=efficiency with 75% rated load ; E4= efficiency with 100% rated load

3. Output :

3.1 DC Output	Voltage	+12V ±5%
	Current	2.0A Max.
	Regulation	11.4Vmin. ~ 12Vtyp. ~ 12.6Vmax.
	Ripple & Noise	120 mV Max.
	Total Power	24W Max.

Remark : For ripple & noise measurement, use a 20MHz bandwidth frequency oscilloscope, and add a 0.1μF multilayer Cap. and a Low ESR Electrolytic Cap. (10 μF) at output connector terminals. (At nominal line voltage, Full Load)

4. Protection :

4.1 Over Voltage Protection (OVP)	22V Max
4.2 Short Circuit Protection (SCP)	Automatic recovery after short-circuit fault being removed
4.3 Over Current Protection(OCP)	5A Max

Remark : When Short Circuit Protection is activated,the power supply will shutdown automatically.

Once the abnormal condition resulting in the failure being removed, the power supply will restart accordingly. When

Over Voltage Protection is activated, the power supply will shutdown.

5. Safety 、 EMI and EMC Requirement :

5.1 Safety Requirement

a. Safety : PSE

b. Dielectric Strength : 10mA Max. Cut off current

(1)	Primary to Secondary	3000Vac for 1 Minute
-----	----------------------	----------------------

c. Insulation Resistance :

(1)	Primary to Secondary	10 M Ohm for 500Vdc
-----	----------------------	---------------------

5.2 EMI Requirement : Class B ; Conduction & Radiation Met.

5.3 Leakage Current : Less than 0.25mA

6. Operation and Environment Performance :

6.1 Temperature Range

Operating	+ 0°C ~ + 40°C
Storage	- 20 °C ~ + 80 °C

6.2 Humidity Range(Non-condensing)

Operating	20% ~ 80% RH
Storage	10% ~ 90% RH

6.3 Cooling : By natural air

7. M.T.B.F. : 300000Hrs.(Calculated Hours at 25°C , By Telcordia SR-332)

8.Mechanical :

8.1 Weight : 170 g Typical

8.2 Cable Type : Black UL2468 22AWG
(Wire + Plug)

Plug : $\varnothing 5.5 \times \varnothing 2.1 \times 9.5 \text{mm}$
(Tuning Fork & Cannelure)

8.3 Cable Length : 1500mm

8.4 Case Dimension : 72mm(L)*34mm(W)*69mm(H) ($\pm 1 \text{mm}$)

8.5 Material Flammability : UL 94V-0

8.6 External Appearance : As drawing below (Scale \rightarrow mm)

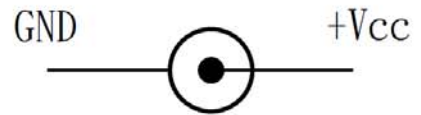

Output Cable Plug Pin Assignment

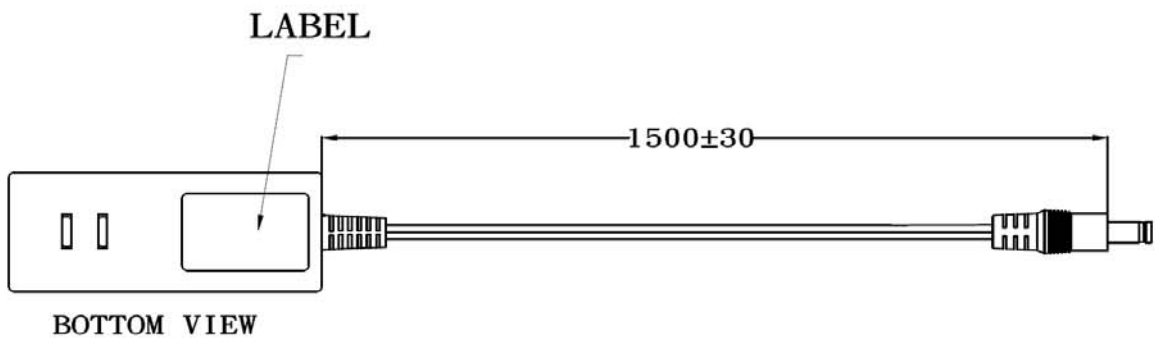
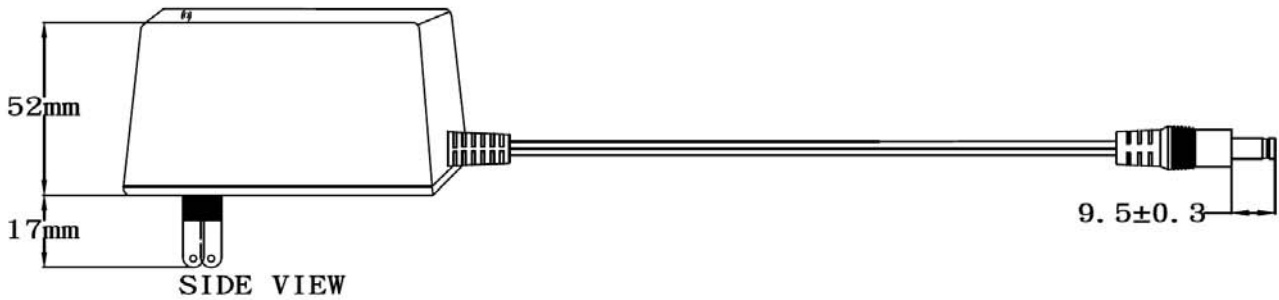
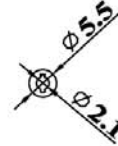

8.7 Spec. Label Materials : Metalized Polyester Label (Silver Gloss)
 Color : Black Background with Silver Printing
 Label Dimension : 34.5mm(L)*24.5mm(W)+/-0.1mm
 Label Thickness : #75

100%

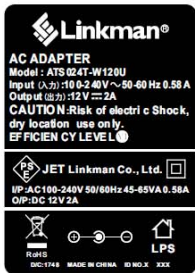

300%

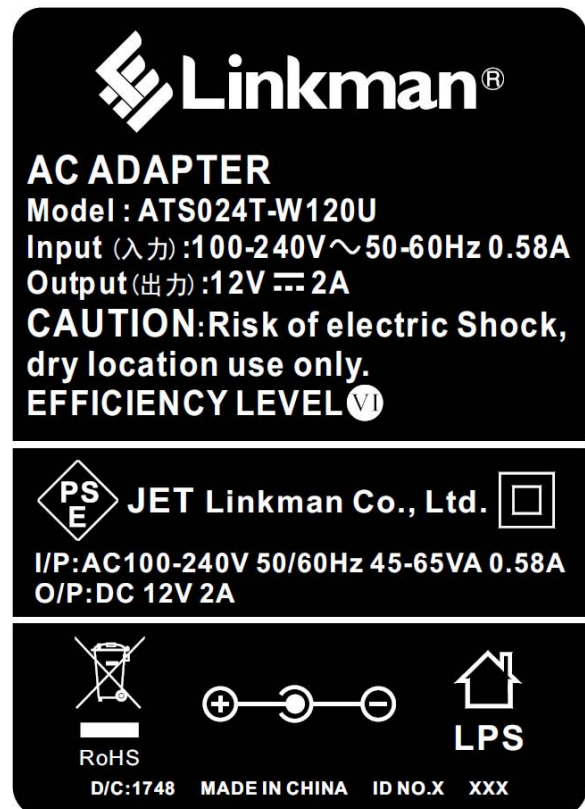

"XXX"

Label supplier's code.
 It is accurate that the number of words depends on the real finished product.

ID NO."X"

Manufacturer's code.
 It is accurate that the number of words depends on the real finished product.

Label Part No. : 9443084410

A. Line Regulation Test

Test Result :

Test condition	Spec.	Reading 1	Reading 2	Reading 3
90Vac / 50 % Load	11.4~12.6 V	11.966V	11.952V	11.984V
115Vac / 50 % Load	11.4~12.6 V	11.966V	11.952V	11.984V
132Vac / 50 % Load	11.4~12.6 V	11.966V	11.952V	11.984V
180Vac / 50 % Load	11.4~12.6 V	11.966V	11.952V	11.984V
230Vac / 50 % Load	11.4~12.6 V	11.966V	11.952V	11.984V
264Vac / 50 % Load	11.4~12.6 V	11.966V	11.952V	11.984V

B. Efficiency Test

Test Result :

Test condition	Spec.	Reading 1	Reading 2	Reading 3
115Vac	86.204% Min.	86.783%	86.523%	86.582%
230Vac	86.204% Min.	87.179%	86.988%	87.004%

$$\text{Eff (av)} = \frac{E1 + E2 + E3 + E4}{4}$$

E1=efficiency with 25% rated load ; E2= efficiency with 50% rated load
E3=efficiency with 75% rated load ; E4= efficiency with 100% rated load

C. Load Regulation Test

Test Result :

Test condition	Spec.	Reading 1	Reading 2	Reading 3
115Vac / 0 % Load	11.4~12.6 V	12.123V	12.114V	12.141V
115Vac / 50 % Load	11.4~12.6 V	11.966V	11.952V	11.984V
115Vac / 100 % Load	11.4~12.6 V	11.811V	11.801V	11.833V
230Vac / 0 % Load	11.4~12.6 V	12.123V	12.114V	12.141V
230Vac / 50 % Load	11.4~12.6 V	11.966V	11.952V	11.984V
230Vac / 100 % Load	11.4~12.6 V	11.811V	11.801V	11.833V

D. Ripple & Noise Test

Test Result :

Test condition	Spec.	Reading 1	Reading 2	Reading 3
115Vac / 100 % Load	120mVpp Max	36.4mVpp	38.4mVpp	32.6mVpp
230Vac / 100 % Load	120mVpp Max	43.2mVpp	46.4mVpp	40.2mVpp

E. Inrush Current

Test Result :

Test condition	Spec.	Reading 1	Reading 2	Reading 3
100Vac / 100 % Load	50A Max.	34.2A	35.2A	33.2A
230Vac / 100 % Load	60A Max	54.3A	52.4A	52.4A

F. Over Current Protection

Test Result :

Test condition	Spec.	Reading 1	Reading 2	Reading 3
115Vac	5A Max	3.05A	3.00A	3.10A
230Vac	5A Max	3.01A	2.98A	3.04A

G. Short Circuit Protection

Test Result :

Test condition	Spec.	Reading 1	Reading 2	Reading 3
115Vac	Auto Recovery	OK	OK	OK
230Vac	Auto Recovery	OK	OK	OK

H. Input Power Consumption(No Load)

Test Result :

Test condition	Spec.	Reading 1	Reading 2	Reading 3
230Vac / 0 % Load	$\leq 0.1W$	0.071W	0.070W	0.071W

Efficiency Test Report

- A. Model Number : ATS024T-A/P/W120Z 12.0V 2.00A 24.00W
- B. DC Power Cord : UL2468 22WG , 1.5M
- C. Average Efficiency :
- Erp (Stage 2) $0.063 * \ln(\text{Nameplate Output}) + 0.622 = 82.222\%$ Min.
- MEPS V $0.0626 * \ln(\text{Nameplate Output}) + 0.622 = 82.095\%$ Min.
- DOE Level VI $0.071 * \ln(\text{Pout}) - 0.0014 * \text{Pout} + 0.67 = 86.204\%$ Min.
- GEMS VI $0.071 * \ln(\text{Pout}) - 0.0014 * \text{Pout} + 0.67 = 86.204\%$ Min.
- COC Tier 2 $0.071 * \ln(\text{Pno}) - 0.00115 * \text{Pno} + 0.67 = 86.804\%$ Min.
- COC Tier 2 (10% Load) $0.071 * \ln(\text{Pno}) - 0.0014 * \text{Pno} + 0.57 = 73.448\%$ Min.
- D. NO Load Power Consumption :
- Erp (Stage 2) 0.3W Max.
- MEPS V 0.3W Max.
- DOE Level VI 0.1W Max.
- GEMS VI 0.1W Max.
- COC Tier 2 0.075W Max.
- E. Testing Equipment :
- a. AC Power Source : " Zentech " 2700M-10
- b. Electronic Load : " PRODIGIT " 3311C
- c. Power Meter : " YOKOGAWA " WT-210A
- d. Digital Meter : " FLUKE " 45
- F. AC Input Voltage : 115Vac/60Hz

Load Conditions	100%* I ₀	75%* I ₀	50%* I ₀	25%* I ₀	10%* I ₀	0%* I ₀
Reported Quantity						
Rms Output Current(mA)	2000mA	1500mA	1000mA	500mA	200mA	0mA
Rms Output Voltage(V)	11.817V	11.914V	12.012V	12.110V	12.168V	12.208V
Active Output Power(W)	23.63W	17.87W	12.01W	6.06W	2.43W	0.00W
Rms Input Voltage(V)	115V	115V	115V	115V	115V	115V
Rms Input Current(A)	0.446A	0.349A	0.255A	0.148A	0.068A	0.012A
Rms Input Power(W)	27.630W	20.560W	13.730W	6.893W	2.850W	0.048W
Power Consumed by UUT(W)	3.996W	2.689W	1.718W	0.838W	0.416W	0.048W
Efficiency	85.537%	86.921%	87.487%	87.843%	85.389%	*
Average Efficiency	86.947%				85.389%	*

- G. AC Input Voltage : 230Vac/50Hz

Load Conditions	100%* I ₀	75%* I ₀	50%* I ₀	25%* I ₀	10%* I ₀	0%* I ₀
Reported Quantity						
Rms Output Current Load Conditions	2000mA	1500mA	1000mA	500mA	200mA	0mA
Rms Output Voltage(V)	11.816V	11.914V	12.012V	12.110V	12.169V	12.208V
Active Output Power(W)	23.63W	17.87W	12.01W	6.06W	2.43W	0.00W
Rms Input Voltage(V)	230V	230V	230V	230V	230V	230V
Rms Input Current(A)	0.304A	0.237A	0.164A	0.090A	0.042A	0.015A
Rms Input Power(W)	27.340W	20.450W	13.730W	6.923W	2.931W	0.067W
Power Consumed by UUT(W)	3.708W	2.579W	1.718W	0.868W	0.497W	0.067W
Efficiency	86.437%	87.389%	87.487%	87.462%	83.037%	*
Average Efficiency	87.194%				83.037%	*

Tester : Wei

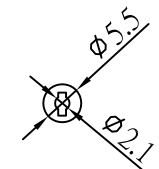
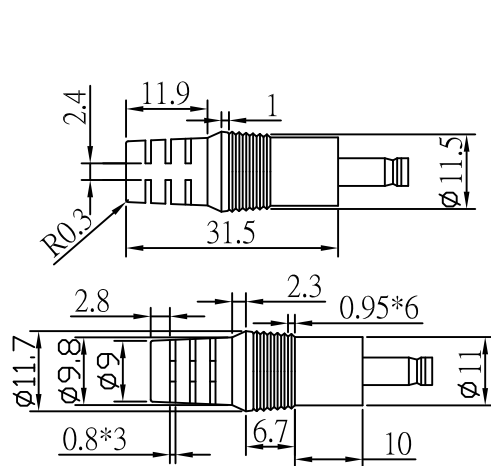
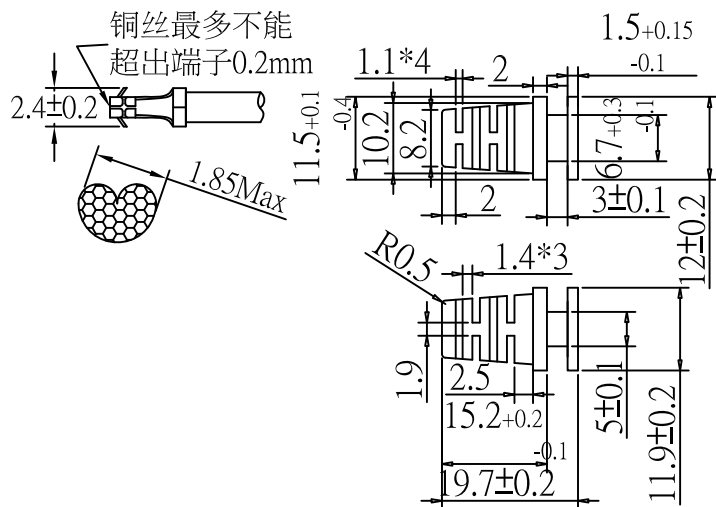
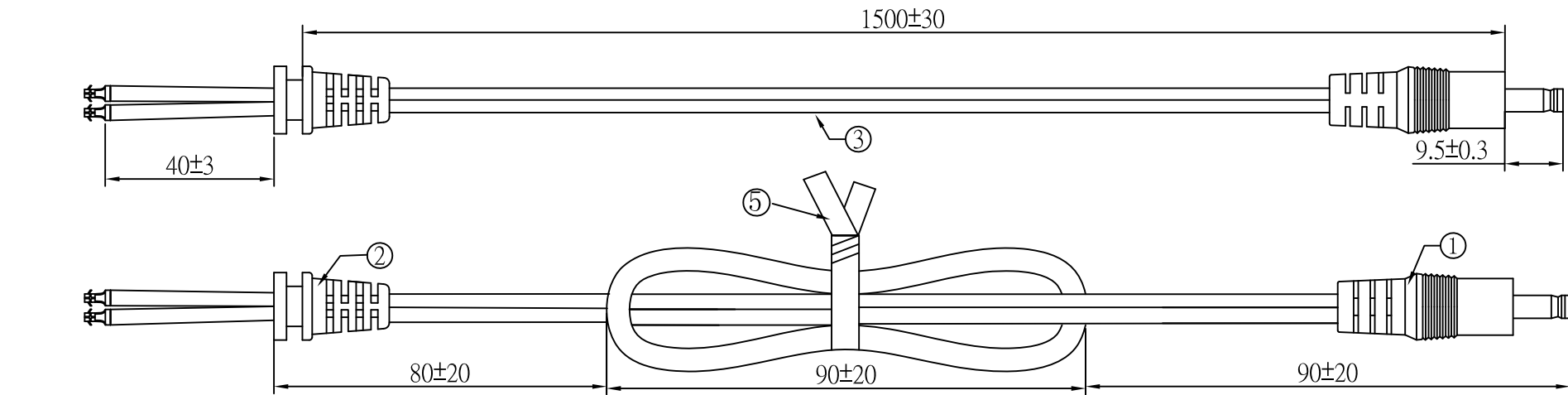

"+" 條紋	"-" 印字
-----------	-----------

注意:此圖面所需材料符合"ROHS"標準

- ① 5.5*2.1*21音叉車溝黑色半邊,外模P-184號模(二次成型),用料外PVC60P黑色(YY-PV-00009)
- ② SR-101號模,用料PVC60P黑色,吊重:1米/20磅/60秒
- ③ UL 2468 22AWG(0.16*17) BK OD:1.8*3.6 裁線長度:1560+10/-0
- ④ PE无鐵芯紮帶10CM黑色(YY-ES-00001)
- ⑤ 1.8双钩机板端*2PCS(进文提供:P1815-A)
- ⑥ 單位:MM

一般公差表			
1.0mm以下	±0.1mm	15.0mm以下	±0.60mm
2.0mm以下	±0.15mm	20.0mm以下	±0.80mm
3.0mm以下	±0.20mm	30.0mm以下	±1.0mm
10.0mm以下	±0.50mm	30.0mm以上	±1.2mm

料號	R44M1C150170		
客戶		制圖	潘胜
頁數	01	審核	
		批準	

02	SR后留尺寸	2015/08/29
01	新出	2015/04/20
版次	變更內容	日期

圖號	ADT-3433	日期	2015/08/29
----	----------	----	------------