

CONTACT & WIRE ASSEMBLY

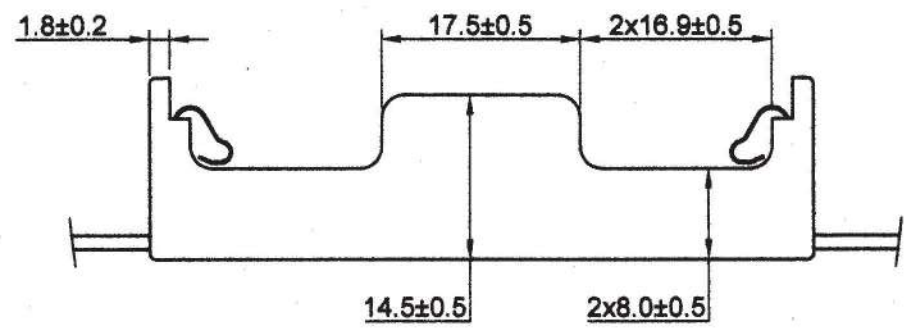

1. ANODE CONTACT & WIRE COMBINATION  
MATERIAL: BRASS NICKEL PLATED

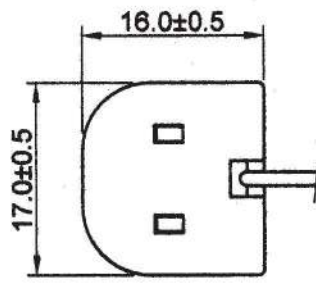
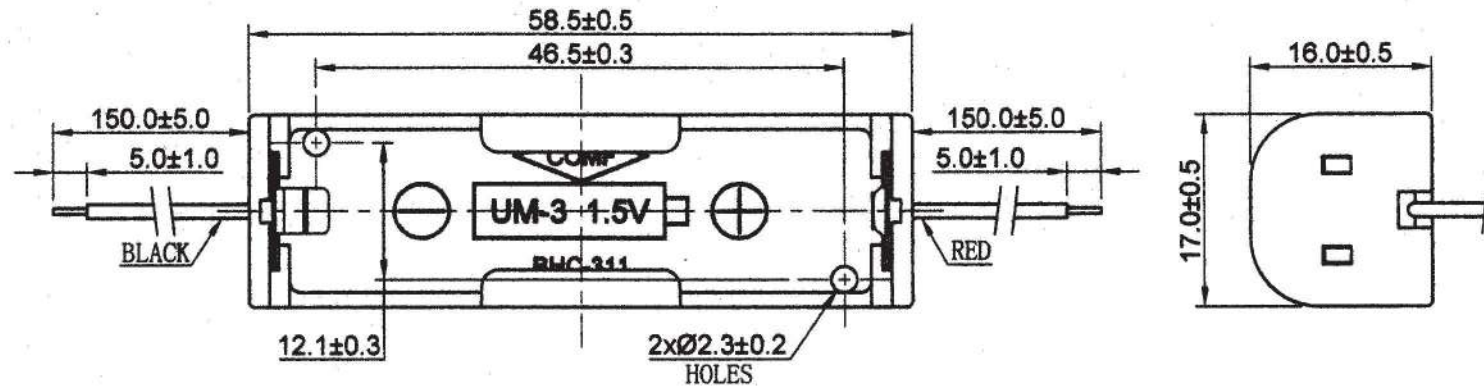
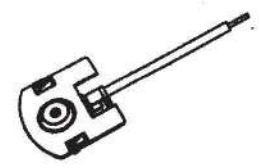

2. CATHODE CONTACT & WIRE COMBINATION  
MATERIAL: PHOSPHOR BRONZE NICKEL PLATED

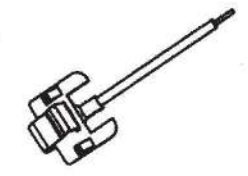

SPECIFICATION

- (1) ITEM NO. : BHC-311A150MM
- (2) WIRE: UL1007 AWG #26  
BLACK & RED: 150MM±5MM  
STRIP & TIN: 5MM±1MM
- (3) HOLDER MATERIAL: PP UL94HB RESIN, BLACK COLOR
- (4) CONTACT MATERIAL:  
ANODE: 0.25MM THICK BRASS NICKEL PLATED  
CATHODE: 0.25MM THICK PHOSPHOR BRONZE NICKEL PLATED
- (5) RoHS COMPLIANT

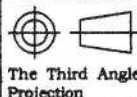
3							
2							
1							
NO.	MODIFICATION	DATE	NAME	BATTERY HOLDER: BHC-311A150MM			
			SCALE	1.5:1	APPD	游原正	
General Tolerances			UNIT	MM	CHKD	黄永连	
0~>3	± 0.10	30~>120	MAT'L	SEE SPEC.	DWN	RAOXIANHUI	
3~>6	± 0.10	120~>400	DATE	NOV. 10. 2014	DR NO	311A-1114	
6~>30	± 0.20	Angle: ±3°	 The Third Angle Projection				