

Characteristics/主要技术特性参数:

Item/项目	Voltage/电压	No-load speed/空载转速	No-load current/空载电流	Terminal resistance/端电阻	Load torque/额定负载	Load speed/负载转速	Load current/负载电流	Reduction ratio/减速比	Max Rated torque/最大额定容许扭力	Max momentary torque/最大瞬间容许扭力
UNIT/单位	V	RPM	mA	Ω	gf. cm	RPM	mA		gf. cm	gf. cm
Date/数值	6.0	166 ± 15%	80 Max	46.5 ± 15%	—	—	—	50/1	400	1200

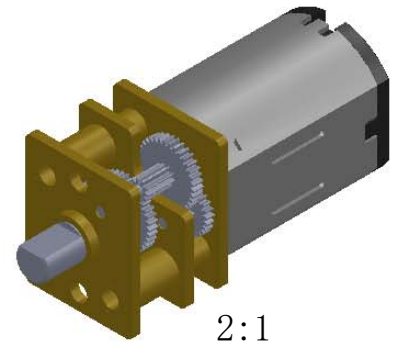

技术要求:
 1、Unit/单位: mm;
 2、未注尺寸公差按: DIN ISO 2768-m T1 and T2;
 3、符合欧盟ROHS最新指令要求, 具体限值要求详见我司最新版《符合产品环境管理物质保证书》。

					图面番号				Outline Drawing
					C1224-166-6.0-12MS50-0217				
REV	QTY	document number	SIGN	Date	Marking		qty	Wight	scale
Design	黄水辉	2019/06/27	Standard				1		3:1
Check	邱传松	2019/06/27	Process						
Approve			REV	01	page 1/1				