

SMD Power Inductor CDH74

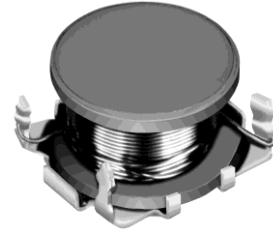

Description

- Ferrite drum core construction
- Magnetically unshielded
- Suitable for Large Current
- Size: 8.0 x 7.3 x H5.2 mm Max.
- Product weight: 0.7g (Ref.)
- Halogen Free available
- Operating temperature range: - 40°C ~ +100°C
(Including coil's self temperature rise)



Applications

- Notebook PC, Projector, LCD TV, Game machine, STB etc. as DC/DC converter inductors

Dimension - [mm]

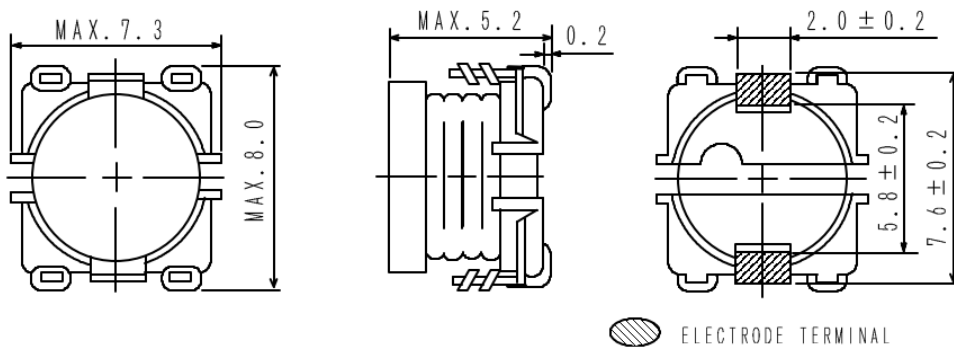

Reference Land pattern - [mm]

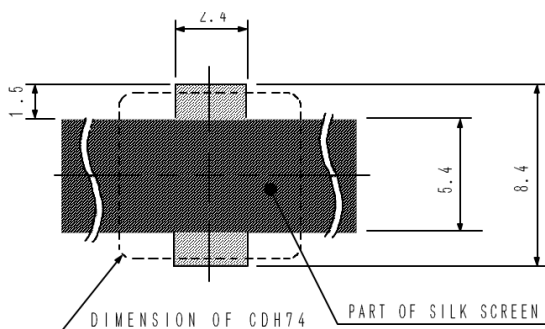

Schematics

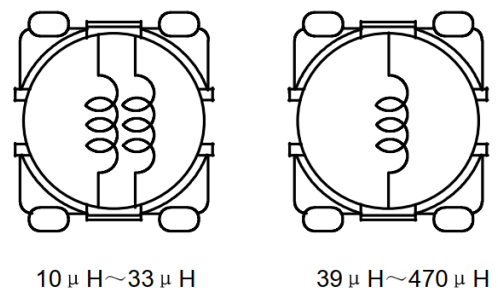

Note : This specification is subject to change without notice. Please contact your nearest sales office for updated information when placing an order.

SMD Power Inductor

CDH74



Electrical Characteristics

Part No.	Inductance ※1	D.C.R (mΩ) Max. (Typ.)	Rated Current (A) 20°C ※2
CDH74NP-100LC	10 μ H±15%	56 (43)	2.75
CDH74NP-120LC	12 μ H±15%	65 (50)	2.45
CDH74NP-150LC	15 μ H±15%	83 (64)	2.10
CDH74NP-180LC	18 μ H±15%	94 (72)	1.95
CDH74NP-220LC	22 μ H±15%	130 (100)	1.70
CDH74NP-270KC	27 μ H±10%	160 (120)	1.55
CDH74NP-330KC	33 μ H±10%	170 (130)	1.45
CDH74NP-390KC	39 μ H±10%	210 (160)	1.30
CDH74NP-470KC	47 μ H±10%	230 (180)	1.20
CDH74NP-560KC	56 μ H±10%	260 (200)	1.15
CDH74NP-680KC	68 μ H±19%	350 (270)	1.00
CDH74NP-820JC	82 μ H± 5%	480 (370)	0.92
CDH74NP-101JLC	100 μ H± 5%	550 (420)	0.81
CDH74NP-121JC	120 μ H± 5%	620 (480)	0.73
CDH74NP-151JC	150 μ H± 5%	720 (550)	0.71
CDH74NP-181JC	180 μ H± 5%	820 (630)	0.66
CDH74NP-221JC	220 μ H± 5%	1,080 (830)	0.55
CDH74NP-271JC	270 μ H± 5%	1,380 (1,100)	0.48
CDH74NP-331JC	330 μ H± 5%	1,550 (1,240)	0.40
CDH74NP-391JC	390 μ H± 5%	2,090 (1,670)	0.38
CDH74NP-471JC	470 μ H± 5%	2,390 (1,910)	0.33

※ 1 Measuring frequency at 1.0kHz 0.1V

※ 2 Rated current: The value of current when the inductance is 10% lower than its initial value at D.C. superposition or D.C. current when $\Delta T=40^{\circ}\text{C}$ whichever is lower. ($T_a=20^{\circ}\text{C}$)

SMD Power Inductor CDH74



Saturation Current & Temperature Rise Graph

— L (20°C) — L (100°C) — ΔT

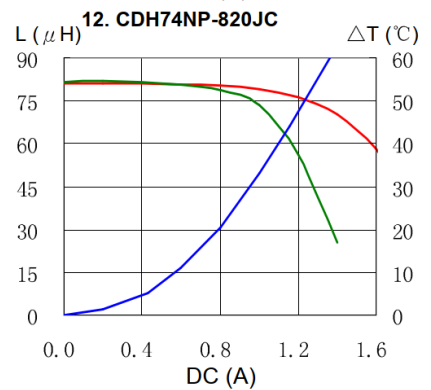
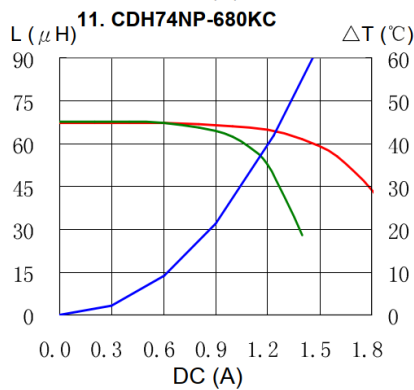
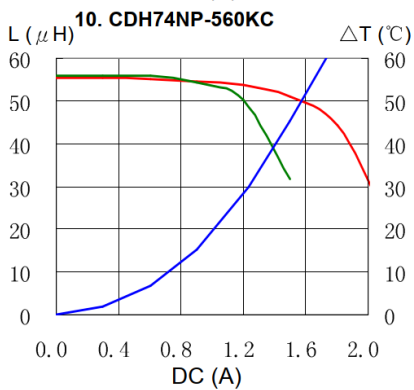
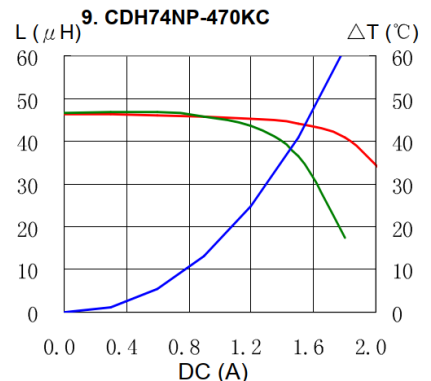
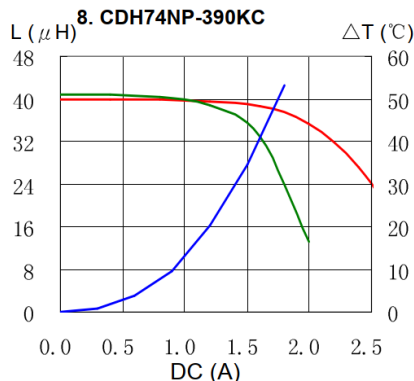
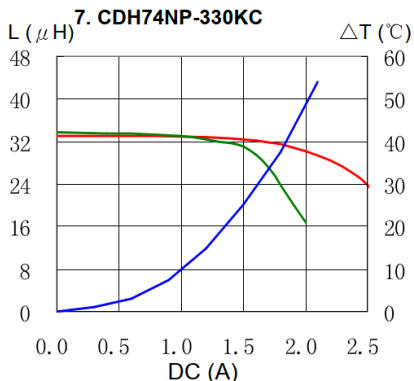
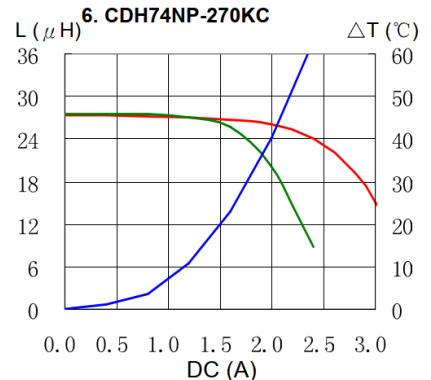
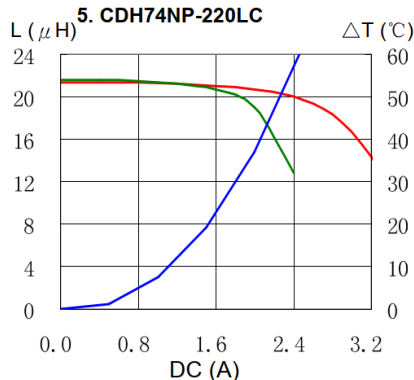
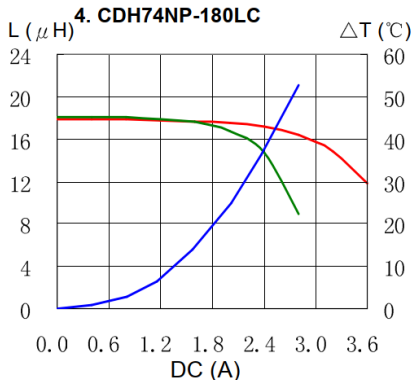
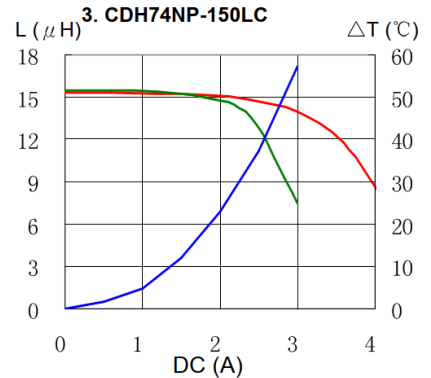
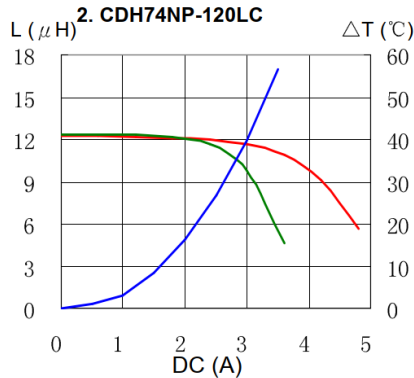
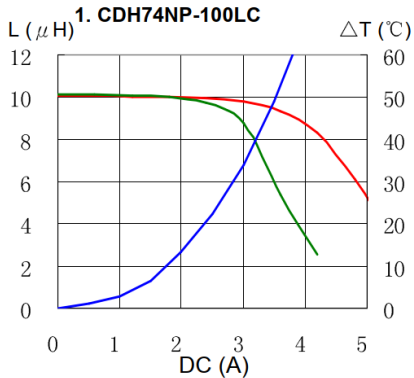

Note : This specification is subject to change without notice. Please contact your nearest sales office for updated information when placing an order.

SMD Power Inductor CDH74

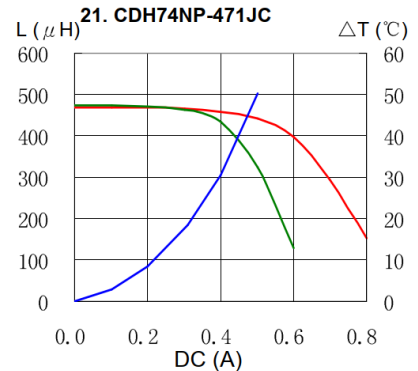
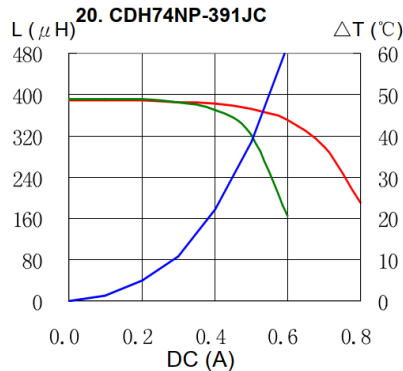
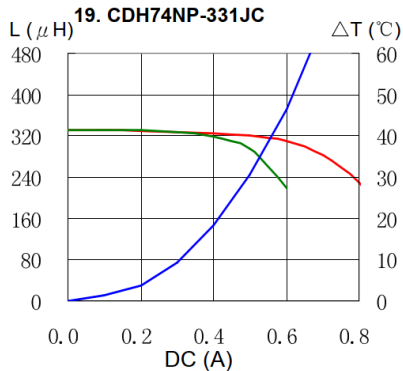
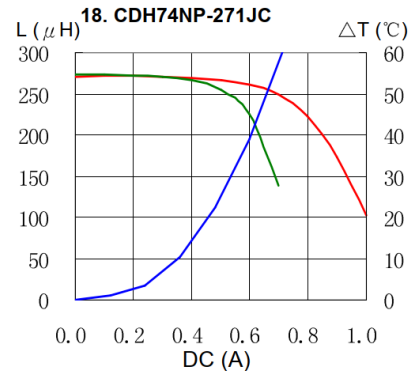
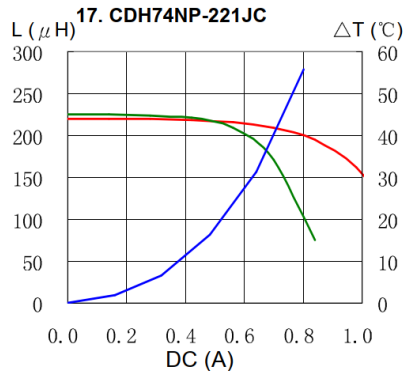
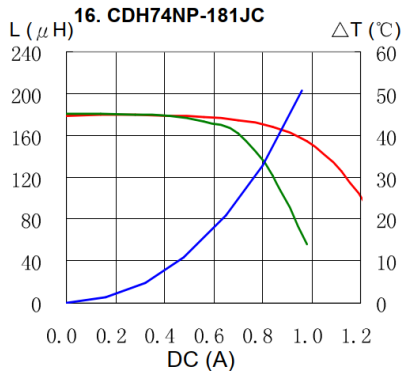
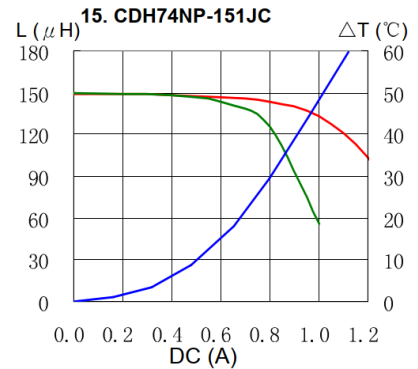
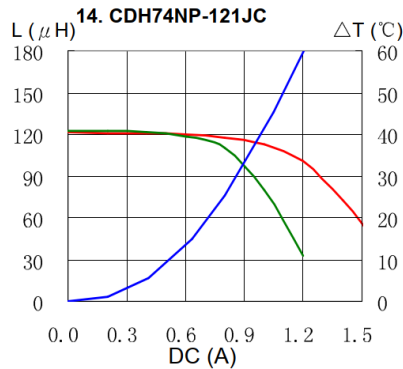
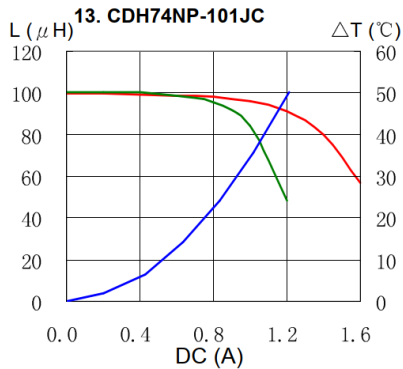

Solder Reflow Condition

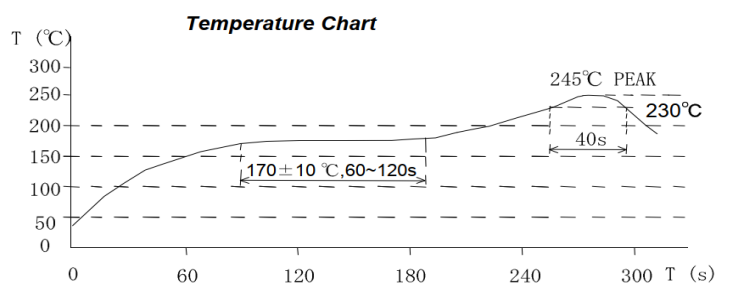
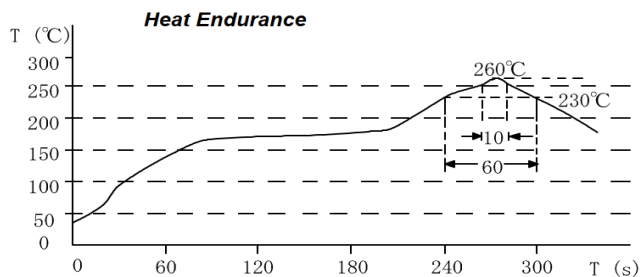

For sales office information, please [click here](#) to visit our website.

Note : This specification is subject to change without notice. Please contact your nearest sales office for updated information when placing an order.