



产··品··规··格··书  
DATA·FOR·APPROVAL

客户名称:

Customer

品 名:

径向引线多层陶瓷电容器

Product Name

Radial Leaded MLCC

规 格:

Product Spec.

CT4-0805B104K

版本号:

Version Number

日 期: Date

客户 Customer			制造 Manufacturer		
确认 Approval			确认 Approval		
检验 Inspector	审核 Checker	批准 Approver	拟制 Designer	审核 Checker	批准 Approver

## 特点

### Feature

\*体积小，容量大，适合自动安装的卷（编）带包装。

Miniature size, large capacitance, tape and reel packaging suitable for auto-placement

\*环氧树脂封装，从而具有优良的防潮性能、机械强度及耐热性。

Epoxy resin coating creates excellent performance in humidity resistance, mechanical strength and heat resistance

\*工业生产标准尺寸及多种脚型产品。

Standard size, various lead configuration

介质种类 Dielectric Type	I类介质 Class I	II类介质 Class II	
介质材料 Dielectric Material	温度补偿型 Temperature Compensating	X7R/X5R(B)	Y5V(Y/F)
电气性能 Electrical Properties	电气性能最稳定，几乎不随温度、电压和时间的变化而变化。 It is the most stable one in electrical properties and has little change with temperature, voltage and time.	具有较高的介电常数，容量可做到比I类电容器高，具有稳定的温度特性。 X7R material has high dielectric constant, and its capacitance is higher than class I. These capacitors are classified as having a semi-stable T.C..	介电常数最大，但温度特性较差，对温度、电压等条件较敏感。 Y5V material has highest dielectric constant. Its capacitance and dissipation is sensible to temperature and voltage.
应用 Application	适用于低损耗，稳定性要求高的高频电路，如滤波器、振荡器和计时电路等。 Used in applications where low-losses and high-stability are required, such as filters, oscillators, and timing circuits so on.	适用于容量范围广，稳定性要求不高的电路中，如隔直、耦合、旁路及鉴频等电路中。 Used over a wide temperature range, such in these kinds of circuits, DC-blocking, coupling, bypassing, frequency discriminating etc.	适用于要求大容量，温度变化不大的电路中 Used over a moderate temperature range in application where high capacitance is required.
容量范围 Available capacitance range	0.5pF~0.1uF	100pF~10uF	1nF~10uF

# 订货代码 Ordering Code

举例Eg.     CT4   -0805   B   104   K   500   -   F3  
                   ↑            ↑            ↑            ↑            ↑            ↑            ↑            ↑  
                   A            B            C            D            E            F            G            H

A

: 产品类别 Product Type	
CC4	I类径向引线独石电容器 Class I Dielectric Radial Leded MLCC
CT4	II类径向引线独石电容器 Class II Dielectric Radial Leded MLCC

C

: 温度特性 Temperature Characteristics			
CG	C0G	0±30 ppm/°C	-55~+125 °C
N	NP0		
B	X7R	±15%	-55~+125 °C
Y/F	Y5V	-80%~+30%	-25~+85 °C

E

: 容量偏差 Tolerance			
C	±0.25pF	K	±10%
D	±0.5pF	M	±20%
J	±5.0%	Z	-20~+80%

G

: 产品类别 Packaging Style		
P	盒带包装 Ammo	编带 Tape
T	卷盒包装 Reel	
空白 Blank	散包装 Bulk	

B:

单位: 英寸

Unit: inches

本体外形尺寸规格 (长×宽) Nominal Body Size (Length × Width)			
0805	0.17 × 0.15	1812	0.34 × 0.26
1206	0.20 × 0.18	2225	0.41 × 0.37
1209/ 1210	0.20 × 0.22		

D

: 标称容量 Nominal Capacitance	
前两位为有效数字, 后一位表示零的个数。 First two digits are significant, and the third digit is number of zero. 例如: For example: 104=100000pF            5R6=5.6pF	

F

: 额定电压 Rated Voltage	
前两位为有效数字, 后一位表示零的个数。 First two digits are significant, and the third digit is number of zero. 例如 For example: 500=50V;            101=100V	

H

: 脚距 (单位: mm) Lead Space (Unit: mm)			
F1	2.54	F4	7.50
F2	4.57	F5	3.50
F3	5.08		

尺寸、工作电压及容量关系表  
**Size Code and Voltage VS Capacitance**

尺寸规格 Size Code	外形 Shape	尺寸 (单位: mm) Dimensions (Unit: mm)						工作电压 Voltage	标称容量范围 Available Capacitance Range		
		F ±0.5	H ±1	L max	W max	T max	Φd ±0.1		COG (NPO)	X7R	Y5V
0805	a	2.54/3.5	5				0.45	25	0R5~272	101~105	102~125
	b	2.54	10					50	0R5~222	101~105	102~105
	C1	5.08	5/10	4.2	3.8	3.8		63	0R5~102	101~104	---
	C2	5.08	5								
	C3	5.08	5/10								
1206	a	2.54					0.45	16	0R5~562	101~225	102~106
	b	3.50	10	5.0	4.5	3.8		25	0R5~562	101~225	102~125
	C1	5.08						50	0R5~472	101~684	102~105
1210/ 1209	b	3.50					0.45	25	100~103	471~105	472~155
	C1	5.08	10	5.0	5.5	3.8		50	100~103	471~105	472~205
		100	5R0~103	101~105	---						
1812	b	4.57	10	8.5	6.5	3.8	0.45	25	100~153	471~335	103~335
								50	100~103	471~225	103~225
								100	5R0~103	101~105	---
2225	b	5.50	10	10.5	9.5	4.2	0.45	25	100~473	102~475	103~475
								50	100~273	102~335	103~335
								100	5R0~273	101~105	---

- 其它规格可直接和我们联系。
- Others are available, contact FH.

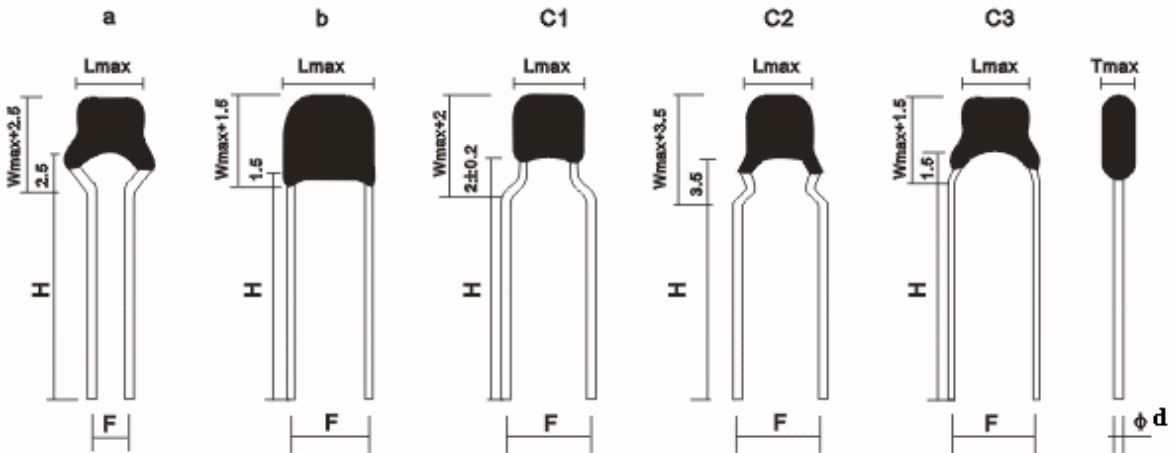

# 通用型引线MLCC可靠性及测试方法

## Reliability and Test Method for General Leaded MLCC

项目 Item	技术要求 Technical Specification		测试方法和备注 Test Method and Remarks		
容量 Capacitance (C)	I类 Class I	应符合指定的误差级别 within the specified tolerance.	标称容量 Capacitance	测试频率 Measuring Frequency	测试电压 Measuring Voltage
			$C \leq 1000\text{pF}$	$1\text{MHZ} \pm 10\%$	$1.0 \pm 0.2\text{V}$
			$C > 1000\text{pF}$	$1\text{KHZ} \pm 10\%$	
	II类 Class II	应符合指定的误差级别 within the specified tolerance.	对于II类电容器, 测试前应先预处理 The capacitance should be pretreated before measured(only for class II).		
			测试频率 Measuring Frequency	测试电压 Measuring Voltage	
			$1\text{KHZ} \pm 10\%$	B: $1.0 \pm 0.2\text{V}$	Y(F) $0.3 \pm 0.2\text{V}$
损耗角正切 Dissipation Factor (DF)	I类 Class I	$C \geq 50\text{pF}$ $\text{DF} \leq 0.15\%$ $C < 50\text{pF}$ $\text{DF} \leq 1.5[(150/C)+7] \times 10^{-4}$	标称容量 Capacitance	测试频率 Measuring Frequency	测试电压 Measuring Voltage
			$\leq 1000\text{pF}$	$1\text{MHZ} \pm 10\%$	$1.0 \pm 0.2\text{V}$
			$> 1000\text{pF}$	$1\text{KHZ} \pm 10\%$	
	II类 Class II	B	$\text{DF} \leq 3.5\%$	测试频率: $1\text{KHZ} \pm 10\%$ ; Measuring Frequency	测试电压: $1.0 \pm 0.2\text{V}$ Measuring Voltage
	Y(F)	$\leq 7.5\%$ ( $C \leq 0.1\mu\text{F}$ ) $\leq 10.0\%$ ( $1\mu\text{F} > C > 0.1\mu\text{F}$ ) $\leq 15\%$ ( $C \geq 1\mu\text{F}$ )	测试频率: $1\text{KHZ} \pm 10\%$ Measuring Frequency	测试电压: $0.3 \pm 0.2\text{V}$ Measuring Voltage	
绝缘电阻 Insulation Resistance	I类 Class I	$C \leq 10\text{nF}$ $\text{IR} \geq 10000\text{M}\Omega$ $C > 10\text{nF}$ $\text{R. } C \geq 100\Omega\text{F}$	测试电压: 额定电压 Measuring Voltage: Rated Voltage 测试时间: $60 \pm 5\text{s}$ Duration: $60 \pm 5\text{s}$		
	II类 Class II	$C \leq 25\text{nF}$ $\text{IR} \geq 4000\text{M}\Omega$ $C > 25\text{nF}$ $\text{R. } C \geq 100\Omega\text{F}$			

项目 Item	技术要求 Technical Specification	测试方法和备注 Test Method and Remarks
耐电压 Withstandi- ng Voltage	不应有介质被击穿或损伤 No breakdown or damage.	端子间Between terminals: 测试电压 持续时间: 5±1秒 Measuring Voltage : Duration: 5±1s I类:300%额定电压 Class I :300% Rated voltage II类:250%额定电压 Class II :250% Rated voltage 充/放电电流不应超过50mA The charge/ discharge current is less than 50mA.
		端子与外装间Between terminals and body: 施加电压: 2.5U <sub>R</sub> 持续时间: 1~5s Voltage: 2.5 times rated voltage Duration: 1~5s 金属制小球法 Small metallic ball method 将电容器本体插入盛满直径为1mm的金属小球的容器中, 但保留距端头处2mm的本体不插入。试验电压施加在短路回路端子和金属小球之间。 Small metallic balls with 1mm diameters shall be put in a vessel and the test capacitor shall be submerged except 2mm from the top of its component body and the terminals. The test voltage shall be applied between the short-circuited terminals and the metallic balls.
可焊性 Solder ability	上锡率应大于95% Lead wire shall be at least 95% covered with a new solder coating.	将电容器引线浸入含有25%松香的酒精溶液中, 然后浸入温度为: 245±2℃的金属焊锡(Sn-3Ag-0.5Cu)中不超过3秒, 注意: 电容器本体底面距离锡面约1.5~2mm, The lead wire of capacitor is dipping into a 25% rosin solution of ethanol and then into molten solder(Sn-3Ag-0.5Cu ) of 245±2℃ for less than 3s. In both cases the depth of dipping is up to about 1.5~2mm from the terminal body.
耐焊接热 Resistance to Soldering Heat	项目 Item	$\Delta C/C \leq$
	Class I	$\pm 2.5\%$ or $\pm 0.25pF$ Whichever is lager
	B	$\pm 10\%$
	Y(F)	$\pm 20\%$
	外观无可见损伤 No significant abnormality in appearance.	
		锡温: 265 ±3℃ 时间: 6(+1,0) s Solder temperature: 265 ±3℃ Duration: 6(+1,0) s 浸入条件: 将电容器插入厚度为1.6mm, 孔径为1.0mm的PC板。 Immersed conditions: Inserted into the PC board (with t=1.6mm, hole=1.0mm diameter) 对于I类介质, 试验后, 应在标准条件下恢复4~24小时后才测试。 Recovery: For class I, 4 to 24 hours of recovery under the standard condition after test. 对于II类介质, 在试验前应先进行如下预处理: 150(-10,+0)℃, 1小时, 接着在标准条件下恢复48 ±4 小时。 Preconditioning (Class II) : 1 hour of preconditioning at 150(-10,+0)℃, followed by 48 ±4 hours of recovery under the standard condition. 恢复: 对于II类介质试验后, 应在标准条件下恢复48 ±4小时后才测试。 Recovery ( Class II) : 48 ±4 hours of recovery under the standard condition after test.

项目 Item	技术要求 Technical Specification		测试方法和备注 Test Method and Remarks		
高温负荷 High Temperature Loading Test	外观无可见损伤 No significant abnormality in appearance.		温度 Temperature		
	容量变化Capacitance Change: I类介质Class I: ≤ ±3% or ±0.3pF取较大值Whichever is larger. II类介质Class II: B: ≤ ±12.5% Y(F): ≤ ±30%		CG (N)	X7R(B)	Y5V(Y/F)
			125(-0,+3)°C		85(-0,+3) °C
	损耗角正切Dissipation Factor: I类介质: 小于原始值的两倍 Class I: Not more than twice of initial value. II类介质Class II: B: ≤ 5.0% Y(F): ≤12.5% (C <sub>R</sub> ≤ 0.1uF) ≤15.0%(1uF > C <sub>R</sub> > 0.1uF) ≤17.5% (C <sub>R</sub> ≥ 1uF)		电压: 1.5倍额定电压 Applied voltage: 1.5 times rated voltage 充放电电流不超过50mA The charge/ discharge current is less than 50mA. 时间: 1000 (-0, +48) 小时 Duration: 1000 (-0, +48) hours 恢复时间: Recovery Time: I类介质: 24 ±2小时, Class I Dielectric : 24 ±2 hours II类介质: 48 ±4小时 Class II Dielectric: 48 ±4 hours		
绝缘电阻Insulation Resistance: ≥ 500M Ω or 25 Ω .F取较小值Whichever is smaller.					
端头强度	抗拉强度 Tensile Strength	无引线断裂或松动等可见不良。 No abnormality such as cut lead or looseness.	固定电容器本体, 沿引线方向逐步施加拉力直至10N, 然后保持10 ±1秒。 Fix the capacitor body, apply the force gradually to each lead in the radial direction of the capacitor until reaching 10N, and then keeping the force for 10 ±1 sec.		
	弯折强度 Bending Strength		对电容器引出端施加一2.5N的力, 使引线弯曲90度, 持续5秒, 然后使引线回到原始位置, 接着反方向操作一次为一个循环, 共重复2次。 Each lead wire shall be subjected to a force of 2.5N and then be bent a angle of 90 degree then returned to initial position. This operation is done over a period of 5 sec. Then second bend in the opposite direction shall be made, repeat 2 times.		

以上所示“标准条件”解释如下: 温度: 5~35°C, 相对湿度: 45~85%, 气压: 86~106kPa

\* Note on standard condition: " standard condition " referred to herein should be defined as follows:

5 to 35°C of temperature, 45 to 75% of relative humidity, and 86 to 106kPa of atmospheric pressure.

若测试结果有争议时, 仲裁试验用标准大气条件为: 温度: 25 ±1°C, 相对湿度: 48%~52%, 气压: 86~106kPa

\* When there are questions concerning measurement results:

In order to provide correlation data, the test should be conducted under a condition of 25 degrees plus/minus 1 centigrade of temperature, 48% through 52% of relative humidity and 86 to 106 kPa of atmospheric pressure.

# 包装形式

## Packaging Style

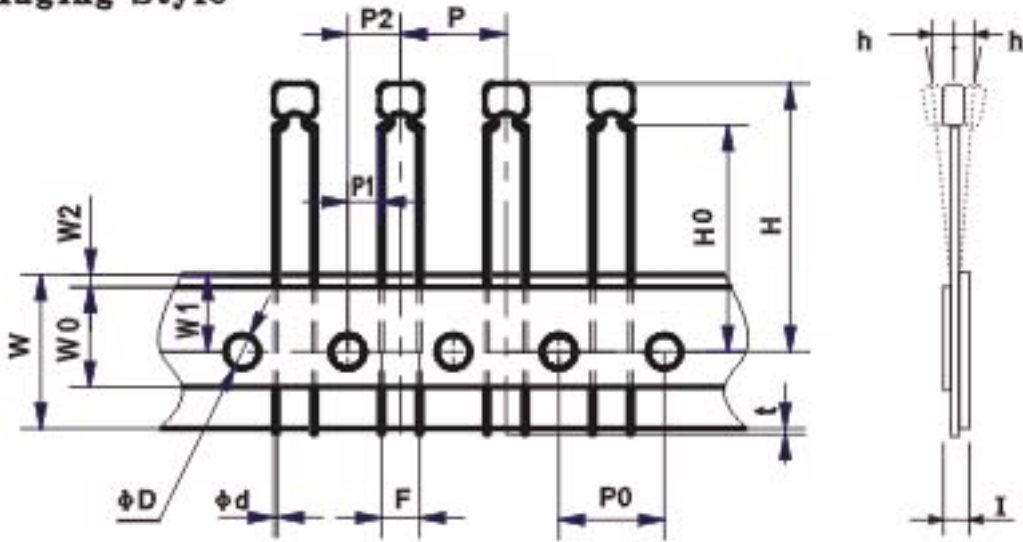

代号 Code	P	P0	P1	P2	d	$\Delta$ h	W	W0	W1	W2	H	H0	I	D	t
尺寸 Dim.	12.7	12.7	3.85	6.35	0.5	0	18.5	9	9	1.5	32.25	15~20	1.42	4.0	0.7
			5.1												
误差 Tol.	±1.0	±0.2	±0.7	±1.3	±0.1	±1	±1	±1	±0.5	±1.5	Max.	±0.5	Max.	±0.2	Max.

注意Note:

P1=3.85mm for F=5.08mm; P1=5.1mm for F=2.54mm.

盒带包装

Ammo Packaging

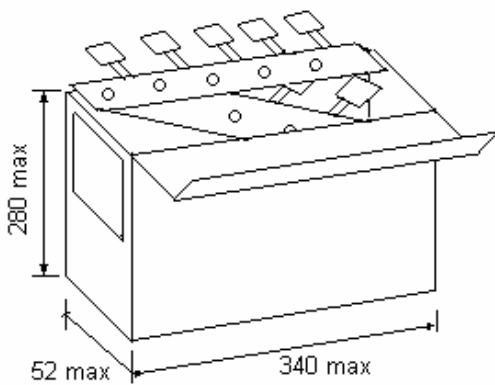

卷带包装

Tape and Reel Packaging

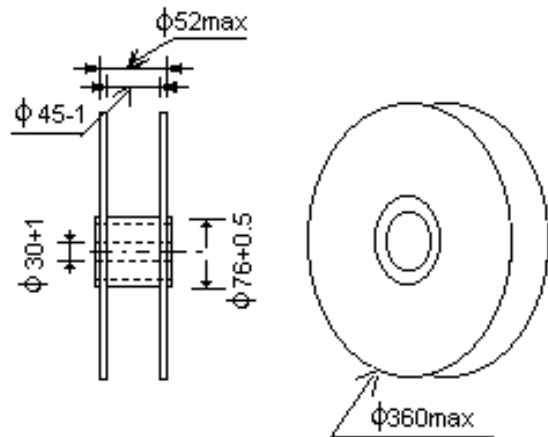

RoHS Compliant