

DIM.	TOL.
5mm DOWN	±0.2
5~20mm	±0.3
20~40mm	±0.4
40~60mm	±0.5
60~100mm	±0.8
100mm UP	±1.0

REVISIONS			
REV	DESCRIPTION	DATE	BY

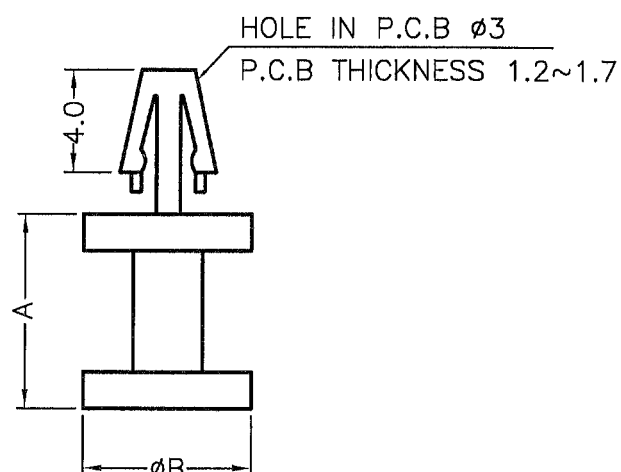
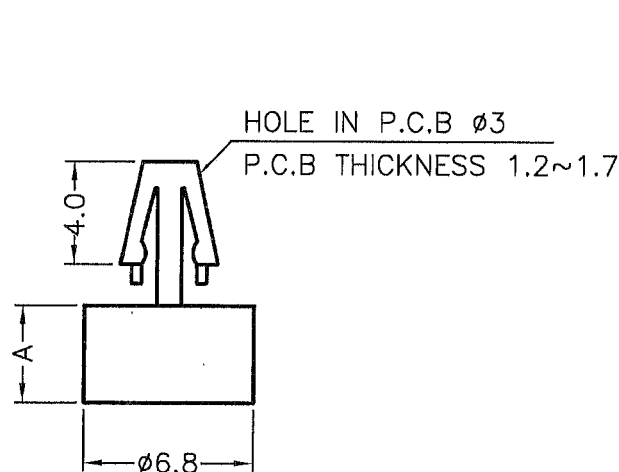

PART NO.	A
DCB-3	3.0
DCB-3.5	3.5
DCB-4	4.0

PART NO.	A	B
DCB-5	5.0	6.0
DCB-5.8	5.8	6.9
DCB-6	6.0	6.8
DCB-6.5	6.5	6.0
DCB-7	7.0	6.0
DCB-8	8.0	6.8
DCB-10	10.0	6.8
DCB-15	15.0	6.0

NOTE: All measurement does not include gate which raises under 0.3mm.

PART NUMBER SEE ABOVE				DRAWING NUMBER DCB		TITLE SPACER SUPPORT		SPEC. DWG.			
				MATERIAL NYLON 66 UL94V-2		FINISH		DATE 2005.12.27		DRAWN JASON	
				COLOR NATURAL		UNLESS OTHERWISE SPECIFIED TOLERANCE SEE ABOVE		CHECK 		APPROVED Kang	
				SIZE A4	SCALE NONE	UNIT mm	REV C				