

TO

APPLICABLE STANDARD				
RATING	OPERATING TEMPERATURE RANGE	-35 °C TO +85 °C (NOTES 1)	STORAGE TEMPERATURE RANGE	-10 °C TO +60 °C (NOTE2)
	VOLTAGE	250 V AC	APPLICABLE CONNECTOR	DF1E- * S-2.5C
	CURRENT	AWG20 TO 24: 3A AWG26: 2A AWG28: 1A AWG30: 0.5A	UL, CSA	VOLTAGE AC 30V CURRENT AWG20 TO 22: 3A AWG24 TO 28: 1A AWG30: 0.5A

SPECIFICATIONS

ITEM	TEST METHOD	REQUIREMENTS	QT	AT
------	-------------	--------------	----	----

CONSTRUCTION

GENERAL EXAMINATION	VISUALLY AND BY MEASURING INSTRUMENT.	ACCORDING TO DRAWING.	X	X
MARKING	CONFIRMED VISUALLY.		X	X

ELECTRIC CHARACTERISTICS

CONTACT RESISTANCE MILLIVOLT LEVEL METHOD.	20 mV MAX, 1 mA(DC OR 1000 Hz).	30 mΩ MAX.	X	-
INSULATION RESISTANCE	500 V DC.	1000 MΩ MIN.	X	-
VOLTAGE PROOF	650 V AC FOR 1 min.	NO FLASHOVER OR BREAKDOWN.	X	-

MECHANICAL CHARACTERISTICS

MECHANICAL OPERATION	30 TIMES INSERTIONS AND EXTRACTIONS.	① CONTACT RESISTANCE: 30 mΩ MAX. ② NO DAMAGE, CRACK OR LOOSENESS OF PARTS.	X	-
VIBRATION	FREQUENCY 10 TO 55 Hz, SINGLE AMPLITUDE 0.75 mm, AT 2 h, FOR 3 DIRECTIONS.	① NO ELECTRICAL DISCONTINUITY OF 1 μs. ② NO DAMAGE, CRACK OR LOOSENESS OF PARTS.	X	-
SHOCK	490 m/s ² DURATION OF PULSE 11 ms AT 3 TIMES FOR 3 DIRECTIONS.		X	-

ENVIRONMENTAL CHARACTERISTICS

RAPID CHANGE OF TEMPERATURE	TEMPERATURE -55→ 5 TO 35→+85→ 5 TO 35 °C TIME 30→ 5 MAX→ 30→ 5 MAX min UNDER 5 CYCLES.	① CONTACT RESISTANCE: 30 mΩ MAX. ② INSULATION RESISTANCE: 1000 MΩ MIN. ③ NO DAMAGE, CRACK OR LOOSENESS OF PARTS.	X	-
DAMP HEAT (STEADY STATE)	EXPOSED AT 40 ± 2 °C, 90 TO 95 %, 96 h.	① CONTACT RESISTANCE: 30 mΩ MAX. ② INSULATION RESISTANCE: 500 MΩ MIN. ③ NO DAMAGE, CRACK OR LOOSENESS OF PARTS.	X	-
RESISTANCE TO SOLDERING HEAT	1) AUTOMATIC SOLDERING (FLOW) SOLDER TEMPERATURE, 260 °C FOR IMMERSION, DURATION, 10 sec. 2) MANUAL SOLDERING SOLDERING IRON TEMPERATURE : 300 °C, SOLDERING TIME : 3 sec. NO STRENGTH ON CONTACT.	NO DEFORMATION OF CASE OF EXCESSIVE LOOSENESS OF THE TERMINALS.	X	-
SOLDERABILITY	SOLDERED AT SOLDER TEMPERATURE, 235 °C FOR IMMERSING DURATION, 5 s.	SOLDER SHALL COVER A MINIMUM OF 95 % OF THE SURFACE BEING IMMERSED.	X	-

COUNT	DESCRIPTION OF REVISIONS	DESIGNED	CHECKED	DATE
△				

REMARKS NOTE1: INCLUDE THE TEMPERATURE RISING BY CURRENT. NOTE2:NO CONDENSING. NOTE3:APPLY TO THE CONDITION OF LONG TERM STORAGE FOR UNUSED PRODUCTS BEFORE PCB ON BOARD,AFTER PCB BOARD,OPERATING TEMPERATURE AND HUMIDITY RANGE IS APPLIED FOR INTERIM STORAGE DURING TRANSPORTATION. Unless otherwise specified, refer to IEC 60512.	APPROVED	KI. AKIYAMA	15.05.23
	CHECKED	TS. FUKUSHIMA	15.05.23
	DESIGNED	TS. KUMAZAWA	15.05.23
	DRAWN	MI. SAKIMURA	15.05.23

Note QT:Qualification Test AT:Assurance Test X:Applicable Test	DRAWING NO.	ELC-161943-35-00
--	-------------	------------------

	SPECIFICATION SHEET	PART NO.	DF1EC-*P-2.5DSA (35)	
	HIROSE ELECTRIC CO., LTD.	CODE NO.	CL541	△ 1/1

1 2 3 4 5 6 7 8

A

B

C

D

E

F

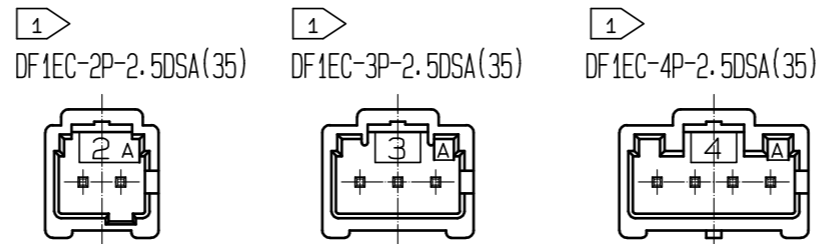
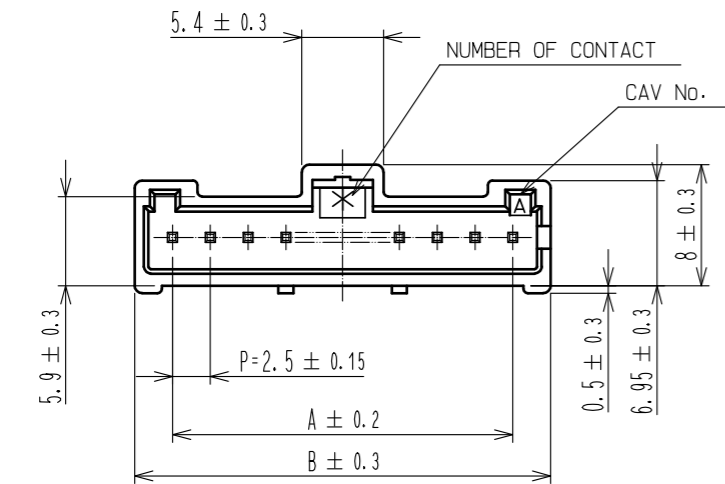

RECOMMENDED PCB LAYOUT(5:1)
(PCB THICKNESS:1.6±0.1)

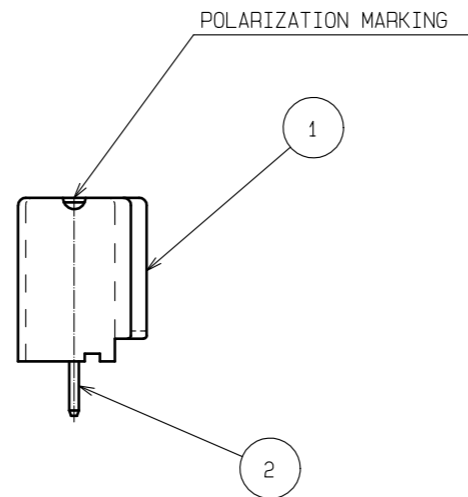
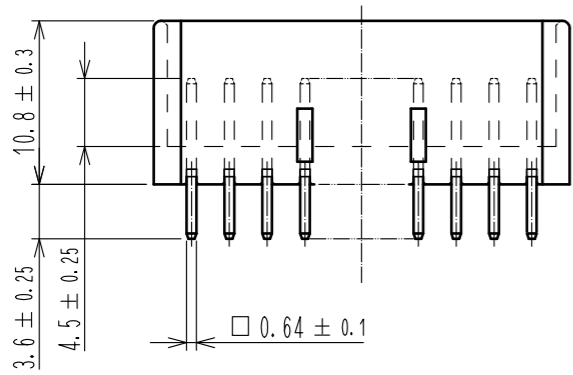
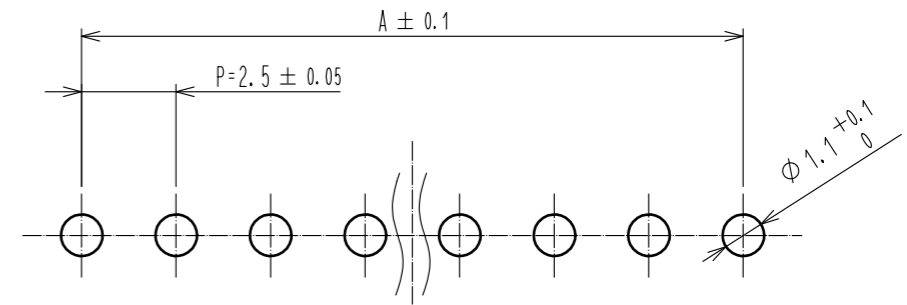

APPLICATION DIAGRAM(3:1)

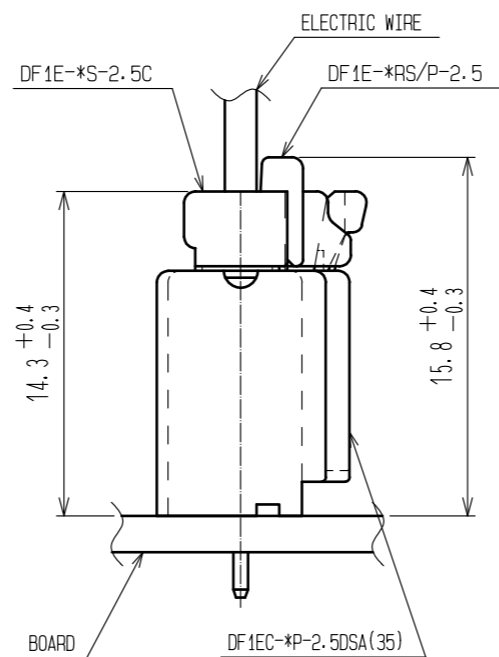
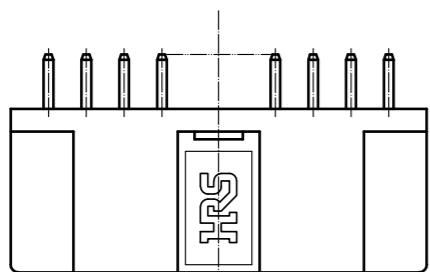
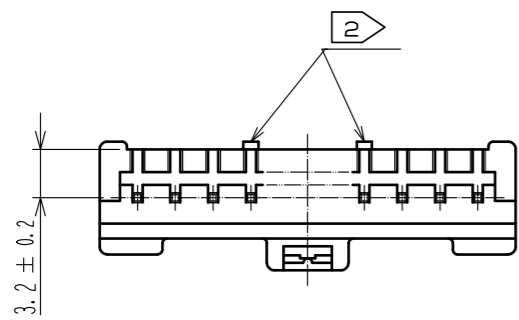

PART No.	CODE No.	NUMBER OF CONTACT	A	B
DF1EC- 2P-2.5DSA(35)	CL541-0867-4-35	2	2.5	7.5
DF1EC- 3P-2.5DSA(35)	CL541-0868-7-35	3	5.0	10.0
DF1EC- 4P-2.5DSA(35)	CL541-0869-0-35	4	7.5	12.5
DF1EC- 5P-2.5DSA(35)	CL541-0870-9-35	5	10.0	15.0
DF1EC- 6P-2.5DSA(35)	CL541-0871-1-35	6	12.5	17.5
DF1EC- 7P-2.5DSA(35)	CL541-0872-4-35	7	15.0	20.0
DF1EC- 8P-2.5DSA(35)	CL541-0873-7-35	8	17.5	22.5
DF1EC- 9P-2.5DSA(35)	CL541-0874-0-35	9	20.0	25.0
DF1EC-10P-2.5DSA(35)	CL541-0875-2-35	10	22.5	27.5
DF1EC-11P-2.5DSA(35)	CL541-0876-5-35	11	25.0	30.0
DF1EC-12P-2.5DSA(35)	CL541-0877-8-35	12	27.5	32.5
DF1EC-13P-2.5DSA(35)	CL541-0878-0-35	13	30.0	35.0
DF1EC-14P-2.5DSA(35)	CL541-0879-3-35	14	32.5	37.5
DF1EC-15P-2.5DSA(35)	CL541-0880-2-35	15	35.0	40.0

- NOTES
- 1 CONFIGURATION OF DF1EC-2P-2.5DSA(35), DF1EC-3P-2.5DSA(35) AND DF1EC-4P-2.5DSA(35).
 - 2 AND 3 OF CONTACTS MAKE DRAWING FORM (PROJECTION) UNNECESSARY, AND 4 OF CONTACTS CONSIDERED AS ONE PROJECTION IN THE CENTER.
 3. UL(FILE NO.E52653).
- C-UL(FILE NO.E52653) APPROVED PRODUCT.



1	POLYAMIDE	NATURAL (BEIGE)・UL94V-0	2	BRASS	SURFACE:TIN PLATED 1μm min UNDER PLATING:NICKEL PLATED 0.5μm min		
NO.	MATERIAL	FINISH . REMARKS	NO.	MATERIAL	FINISH . REMARKS		
UNITS mm		SCALE 2 : 1	COUNT 	DESCRIPTION OF REVISIONS	DESIGNED	CHECKED	DATE
		APPROVED : KI. AKIYAMA	15.05.23	DRAWING NO. EDC-161943-35-00			
HIROSE ELECTRIC CO., LTD.		CHECKED : TS. FUKUSHIMA	15.05.23	PART NO. DF1EC-*P-2.5DSA(35)			
		DESIGNED : TS. KUMAZAWA	15.05.23	CODE NO. CL541-			
		DRAWN : MI. SAKIMURA	15.05.23				

1 2 3 4 5 6 7 8

A

B

C

D

E

F