

ELC12 Series

Instruction Manual

BEFORE USING POWER SUPPLY UNIT

Be sure to read this instruction manual thoroughly before using this product.

Pay attention to all warnings and cautions before using the unit. Incorrect usage could lead to an electrical shock, damage to the unit or a fire hazard.

⚠ DANGER

- Never use this product in locations where flammable gas or ignitable substances are present.

⚠ WARNING ON INSTALLATION

- Follow the installation instructions in this manual. If installation has a defect, there is fear of an electric shock and a fire.
- Qualified personnel (Electrical worker, etc.) who has experience needs to perform installation. There is fear of electric shock and fire.
- Avoid mounting this product using fixing method other than screws (fixing with double-sided tape, or not fixing at all).
- Do not cover with cloth or put paper on this product. Do not place flammable objects nearby. They may cause damage, electric shock or fire.

⚠ WARNING ON USE

- Do not touch the product while it is in operation or immediately after disconnecting power. There is a risk of burns on contact.
- While this product is operating, keep your hands and face away from it as you may be injured by an unexpected accident.
- Do not perform disassembly and reconstruction of this product, otherwise you may receive an electric shock and void your warranty.
- Do not use this product under unusual condition such as emission of smoke or abnormal smell and sound etc. It might lead to fire and electric shock. In such cases, contact us. Do not attempt to repair by yourself, as it is dangerous for the user.

⚠ CAUTIONS ON INSTALLATION

- The power supply unit is for LED lamp load. Never use it for other purpose than LED lamp load
- Protection class IP66 shows initial protection class against dust and water. Performance may degrade depending usage environment. In addition, for connection point of the input and output lines, take appropriate waterproofing. When the water enters inside the power supply from the connection point of the wire, there is a risk of electric shock or fire or smoke
- About connection of input and output line, check that it is performed appropriately as shown in this instruction manual. If wrong wire connection is carried out, it may cause failure, electric shock, or fire. Particularly, be sure to avoid connecting input line and output line in reverse
- When wiring long input wire, use thick wires as possible, and lower input impedance as much as possible
- If dropped or shock is applied to the unit, never use the unit because it might have caused damage.
- Do not use in special environments such as direct sunshine, locations with exposure to water such as rain, strong magnetic field and corrosive gas, etc.
- For applications, which require very high reliability (Nuclear related equipment, traffic control equipment, etc.), it is necessary to provide a fail-safe mechanism in the end equipment.
- When handling this product, carry the main body. Avoid working with input and output line because it might cause damage.

⚠ CAUTIONS FOR USE

- Input voltage, Output current, Output power, ambient temperature and ambient humidity should be kept within specifications, otherwise it may cause failure, electric shock, or fire.
- Never operate the product under over current or short-circuit conditions, or outside its specified Input Voltage Range. Insulation failure, smoking, burning or other damage may occur.
- Notice the abnormal voltage from the external to output. It may become the origin of the trouble (failure, electric shock, or fire) in particular when power supply is applied overvoltage more than the rating voltage or the reverse voltage between the output.

⚠ OTHER CAUTIONS

- Do not keep in places like the following.
 - Places with high temperature or high humidity, places in direct sunshine exposure, places where vibration and shock are applied, places where corrosive gas is emitted.
- When disposing this product, follow the disposal procedures of each local government.
- The information in this document is subject to change without prior notice. Refer to the latest version of the data sheet, etc., for the most up-to date specifications of the product.
- No part of this document may be copied or reproduced in any form without prior written consent of TDK-Lambda.

1. Model Name Identification Method

ELC 12 - 18 - R70

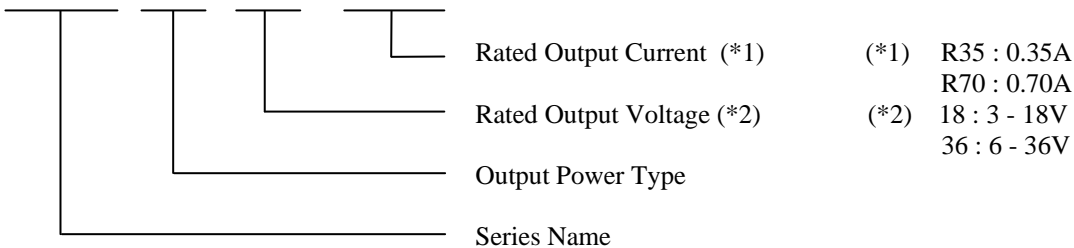

2. Terminal Explanation

- a) L : Input terminal (Brown) Live line (Fuse in line)
- b) N : Input terminal (Blue) Neutral line
- c) Earth : Earth terminal (Green/Yellow) Protective earth
- d) V+ : + Output terminal (Red)
- e) V- : - Output terminal (Black)
- f) Mounting Hole (Hole Size : R2.0mm)

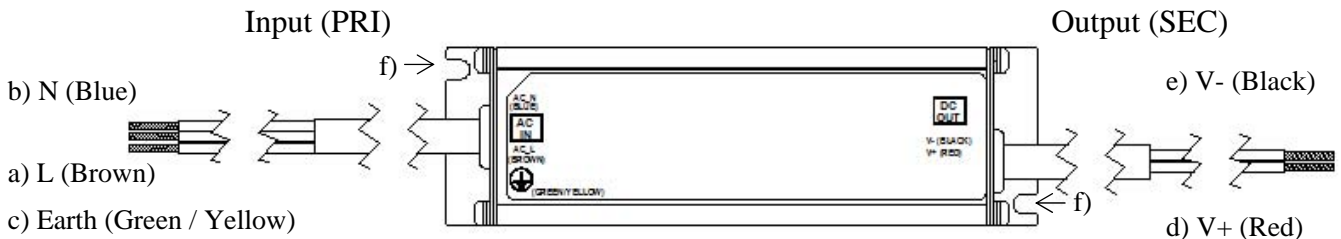

3. Terminal connecting method

Pay extra attention to the input wiring. Wrong connection may cause damage, electric shock or fire. Never connect output wire and input wire in reverse.

- Input must be off when making connections. Input must be turned on after completing wire connection including LED.
- Input wire and output wire shall be separated.
- Take enough consideration to avoid electric shock.
- Do not subject the unit to scratch and undue stress such as bending or pulling the input and output wires.
- When connecting wire, connect firmly by ensuring no loose connection, omission, and no wire being pulled out.
- Input and output wire is not waterproof. If there is risk of contact with water, waterproofing is necessary.
- Do not connect product output in series and parallel connection.
- If PSE is needed, connect output line (V-) to ground. In addition, be sure to connect the earthed line of the input terminal to ground.

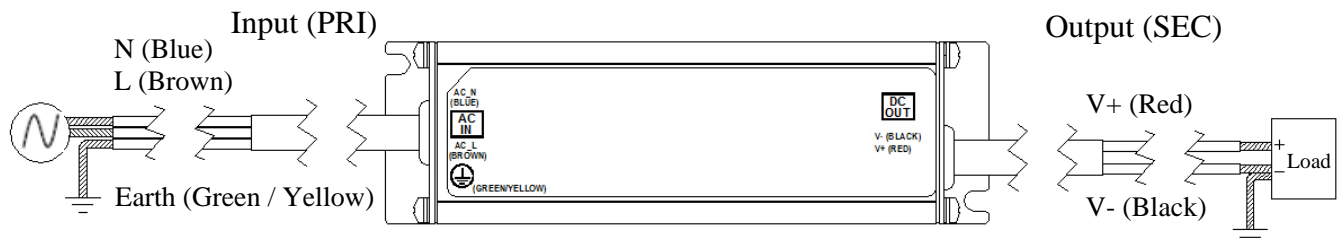

Note : This power supply unit is for driving LED loads.

4. Explanation of Functions and Precautions

4-1. Input Voltage Range

Input voltage range is single phase 90 - 265VAC (47 - 63Hz)

Using this unit outside the input voltage specification range might cause damage to unit. For cases where conformance to various safety specs are required, input voltage range will be 100 - 240VAC (50 - 60Hz).

4-2. Inrush Current

This series is equipped with Power thermistor to limit the inrush current. Since this series employs power thermistor method, inrush current increase at higher ambient temperature or input recycle condition.

4-3. Over Voltage Protection (OVP)

The OVP function will cause the output to shut down. In order to recover output during output shutdown, remove the AC input for a few minutes, then recycle AC input. OVP setting is fixed and cannot be adjusted externally.

4-4. Output Voltage low condition

Output Ripple becomes large at several conditions such as 100V input system ($V_{in} = 90$ to 169VAC) when output voltage is set at approximately 40% or less than the rated voltage, and 200V input system ($V_{in} = 170$ to 265VAC) when output voltage is set approximately 50% or less than the rated voltage.

When using in the above mentioned low voltage load range, please perform operation check sufficiently. In addition, never operate the unit under less than the minimum of the output voltage range (16.7% of rated output voltage) or shorted conditions. This might cause damage to the unit.

4-5. Load terminal disturbance voltage test

To satisfy load terminal disturbance voltage test in PSE, attach electrolytic capacitor : 100uF, film capacitor : 0.1uF to the end of output wire.

4-6. Maximum Load Capacity

Attach capacitor to the load side within the following capacitance.

	Maximum External Capacitance	
Model	ELC12-18-R70	ELC12-36-R35
Capacitance	100uF	100uF

5. Isolation / Withstand Voltage

5-1. Isolation Resistance Test

Isolation resistance between output and earth shall 100MΩ at 500VDC. For safety, voltage setting of DC isolation tester must be done before the test. Ensure that the unit is fully discharged after the test.

Output - Earth : 500VDC 100MΩ or more

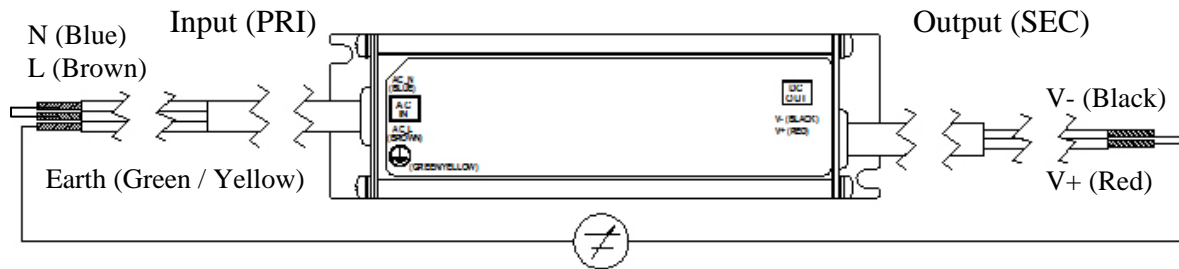

5-2. Withstand Voltage

This series is designed to withstand 3kVAC between input and output , 2kVAC between input and earth for one minute. When testing withstand voltage, set current limit of withstand voltage test equipment at 10mA. The applied voltage must be gradually increased from zero to testing value and then gradually decreased for shut down. When timer is used, the power supply may be damaged by high impulse voltage during timer switch on and off. Connect input and output as follows :

Input - Output : 3kVAC, 1min (10mA)

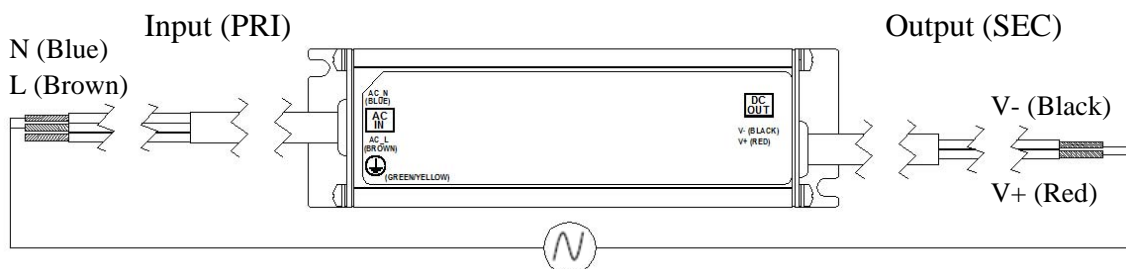

Input - Earth: 2kVAC, 1min (10mA)

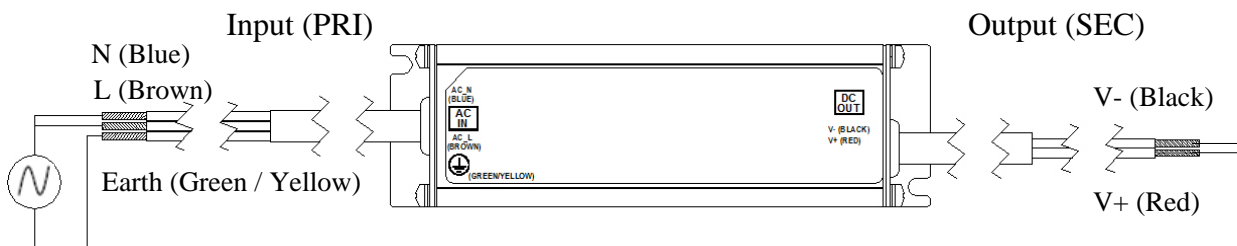

6. Mounting Directions

6-1. Mounting Directions

Recommended standard mounting methods is (A). Methods (B) ~ (E) are also possible.

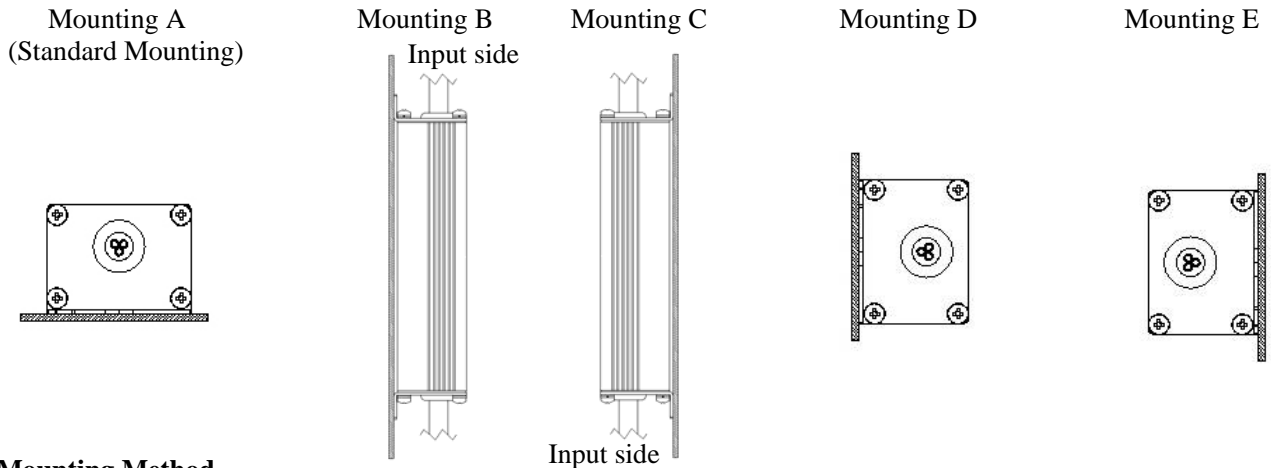

6-2. Mounting Method

- (1) This is a convection cooling type power supply. The power supply itself generates heat. In consideration of the heat radiation and safety, keep a distance more than 15mm between the power supply and the peripheral parts. When lining up multiple units, be sure to place them 15mm or more apart from each other. Avoid unit layout that will prevent heat dissipation such as stacking or piling up one unit over the other. Even when operating ambient temperature is thought to be within the limits of power supply specification, if the power supply is enclosed in a sealed device or apparatus, components temperature in the power supply rises with increase in ambient temperature of the power supply remarkably, which might cause failure.
- (2) Recommended torque for mounting screw (M3 screw) : 0.49N·m (5.0kgf·cm)
- (3) Do not exceed the recommended torque to prevent mechanical stress on the enclosure.
- (4) Secure with the fixing holes in two places.
- (5) Fix the product to a plane surface without stress such as torsion, bend and shock.
- (6) About installed side of the power supply, use structure and materials that sufficiently capable tolerating weight or temperature of the power supply.

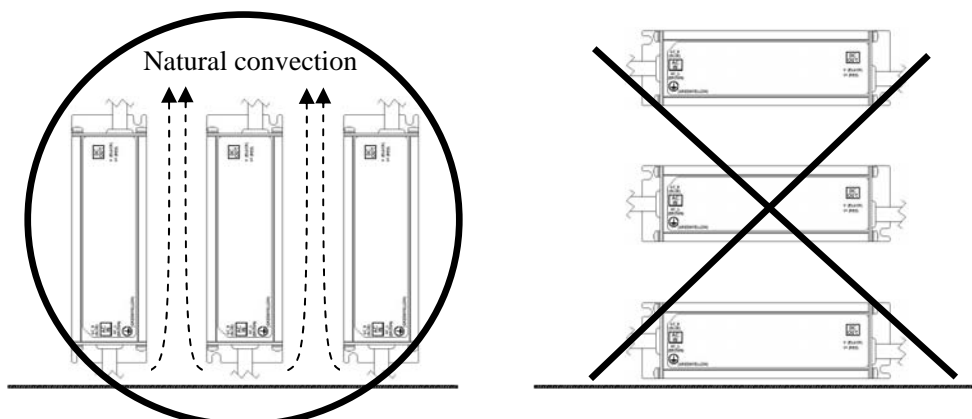
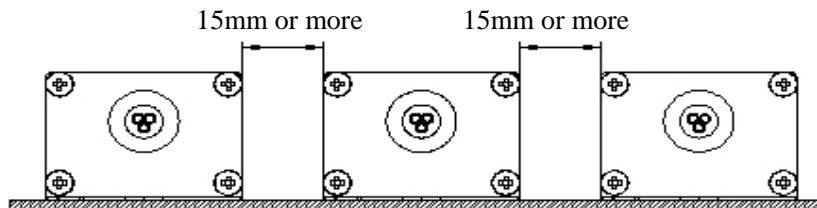

6-3. Output Derating

(1) Vin=90 - 132VAC(169VAC)

Ta (°C)	LOAD (%)
-10 - +60	16.7 - 100

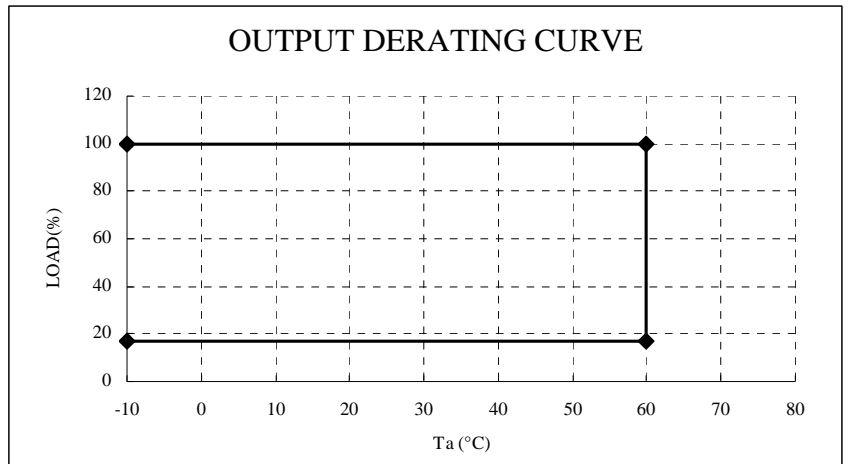

(2) Vin=170 - 265VAC

Ta (°C)	LOAD (%)
-10 - +50	16.7 - 100

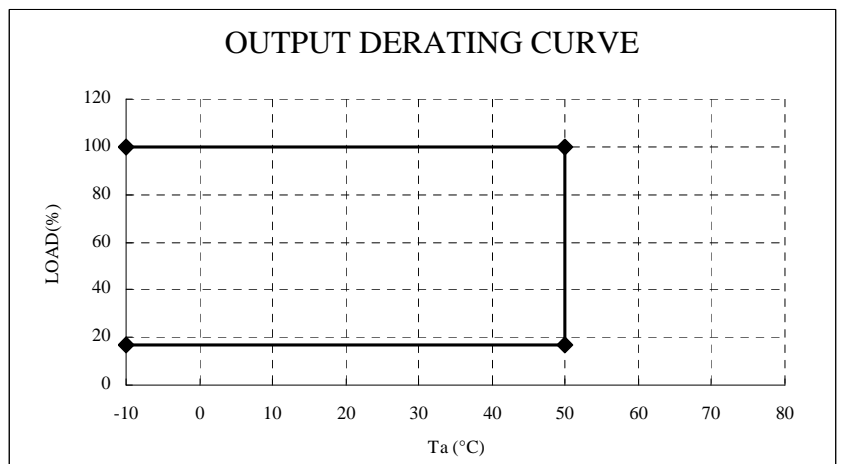

Output Ripple becomes large at several conditions such as 100V input system (Vin = 90 to 169VAC) when output voltage is set at approximately 40% or less than the rated voltage, and 200V input system (Vin = 170 to 265VAC) when output voltage is set approximately 50% or less than the rated voltage.

When using in the above mentioned low voltage load range, please perform operation check sufficiently. In addition, never operate the unit under less than the minimum of the output voltage range (16.7% of rated output voltage) or shorted conditions. This might cause damage to the unit.

7. Wiring Method

- The output wire and input wire should be separated.
- The output wire and input wire should not be pulled in such a manner that it will render mechanical stress to the unit.
- If the input and output lines are long and thin, it may affect the operation of the power supply. Check thoroughly that there is no influence before using.

8. Light modulation control

- Never adjust light modulation control by the PWM switch (etc.) that is connected to the output side of ELC series. This might cause damage to the LED.

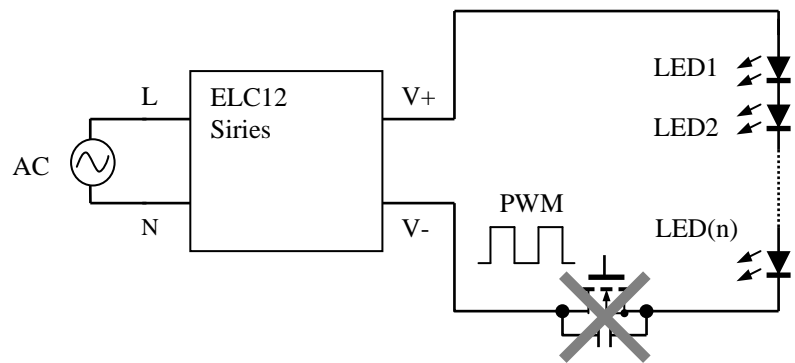

9. Switch (Relay)

- Never use switch (relay) at the output side. This might cause damage to the LED.

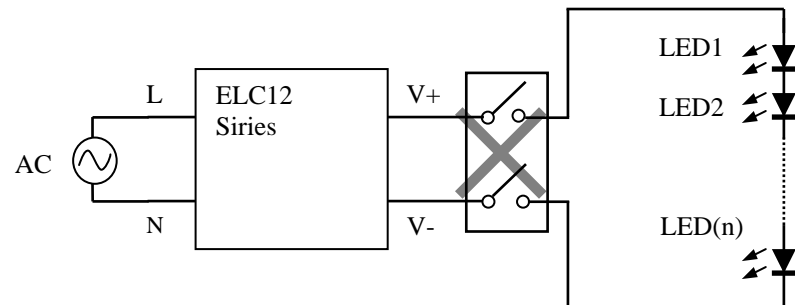

10. LED load connection

- Never make LED wiring connections while the AC power is connected. This might cause damage to the LED.

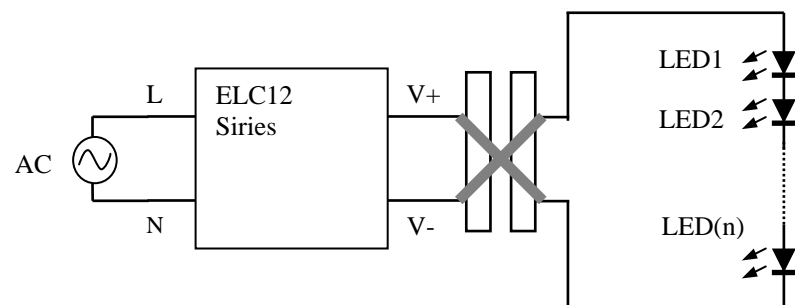

11. Before concluding that the unit is at fault...

- Check if the rated input voltage is applied.
- Check if the wiring of output polarity is correct.
- Check if the output current and output wattage does not exceed the specification.
- Audible noise can be heard during Dynamic Load operation.
- Audible noise can be heard when input voltage waveform is not sinusoidal wave. (connecting UPS, etc.)
- Ensure that large capacitor is not connected on the output side. Use within maximum external capacitance Shown in "4-6. Maximum Load Capacity".

12. Power Supply Lifetime

This product has lifetime. This lifetime changes depending on operating conditions. For reference lifetime years of the power supply, refer to the electrolytic capacitor life expectancy calculated value in the reliability data. When the power supply has exceeded life span, output noise becomes large, output voltage becomes unstable, output voltage drops, etc., causing the power supply not to be able to meet the power supply specifications. Therefore, take enough consideration for environment, and use at low storage temperature, operating ambient . Replacement is recommended before lifetime expires.

13. Maintenance

Structure of the product does not allow repair. Contact TDK-Lambda in case of failure.
Also it is not possible to replace the input wire and output wire.

14. Warranty Period

This product is warranted for a period of 3 years from the date of shipment. For breakdown under normal usage during free warranty term, replacement is free of charge.

Conditions of usage covered by free of charge warranty are as follows.

- (1) Average operating temperature (ambient temperature of the power supply unit) is under 40°C.
- (2) Load factor is less than 100%.
Maximum rating of the load factor and operating temperature are in the range of output derating as provided for in the specifications.

Following cases are not covered by warranty.

- (1) Improper usage like dropping products, applying shock, corrosive gas etc., salt damage etc. and defects from operation exceeding specification of the units.
- (2) Defects resulting from natural disaster (fire, flood).
- (3) Unauthorized modifications or repair by the buyers' defects not cause by our company.