

RoHS compliant

Packing unit on supplement AM0411
 max. torque are 40 Ncm
 Part-No. 9 and 10 not mounted

ØF1 = Cable diameter without rubber bushing ø3 - ø8.5mm
 ØF2 = Cable diameter with rubber bushing max. 6.5mm

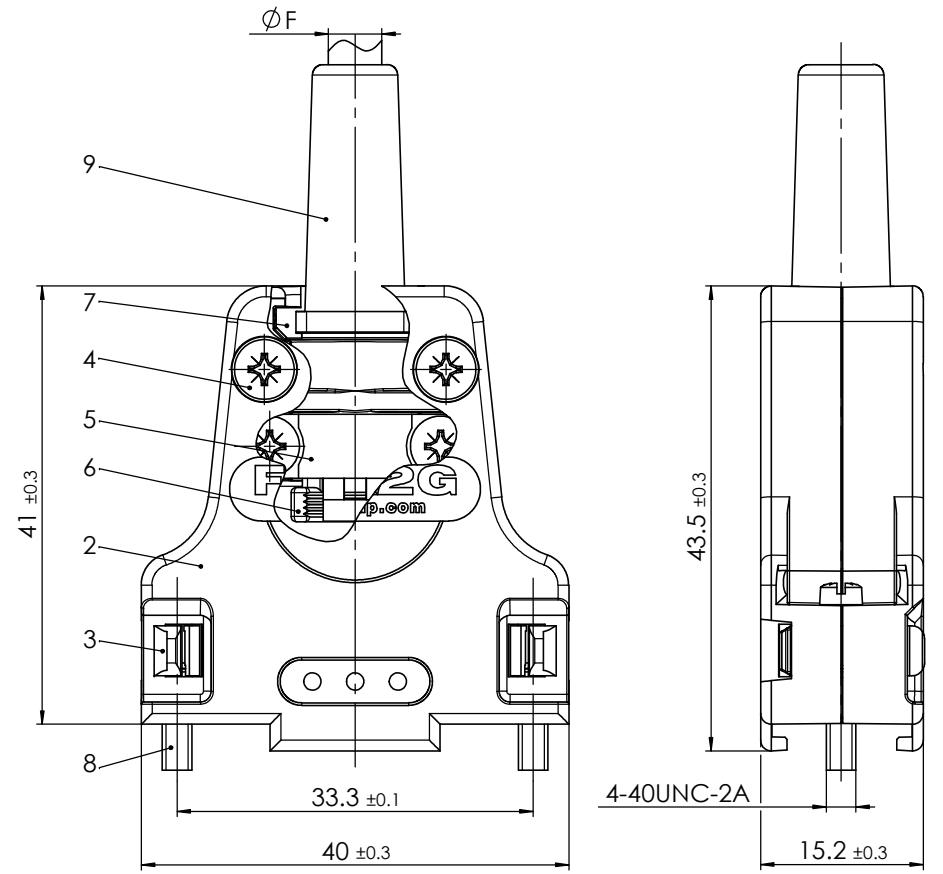

| No. | St. | Part | Type | Description/Material | Surface plating/Colour/Class |
|-----|-----|------------------------|---------------------------|----------------------|------------------------------|
| 10 | 2 | High power contact | FMP006S204 | | AuroPur / 20A / AWG 12-16 |
| 9 | 1 | Rubber bushing | TPE | | black |
| 8 | 2 | Locking screw | FVS1/5-K1163 4-40 / Steel | | nickel plated |
| 7 | 2 | Cable reduction plate | Zinc die-cast | | nickel plated |
| 6 | 1 | Strain relief | ABS | | nickel plated |
| 5 | 1 | Cable clamp | Steel | | tin plated |
| 4 | 4 | Screw | Case hardened steel | | zinc plated |
| 3 | 2 | Catch spring | PEI | | black |
| 2 | 1 | Hood | FMK2G / Zinc die-cast | | nickel plated |
| 1 | 1 | Mixed-Layout Connector | FM7W2SA-K121 | | |

| | | | | | |
|------|------|---------|------------------------------------|------------------|---------|
| 1 | | | | | |
| REV. | DATE | CH.-NO. | ORIGINAL: DIN A3-DRAWING AS A FILE | REPLACEMENT FOR: | PAGES 1 |

Measurement without tolerance occ. to ISO 2768-m

SCALE 2:1

TITLE

NAME / DATE

tschneider01
26-07-2016

DRAWN

BWiftek
01-08-2016

CHECKED

FCT
a mollex company

Hood Connector Set

DWG.NO.

FMK2G-7W2SA-5909

REV.

1

COMMENT: ALL RIGHTS ARE RESERVED BY US FOR THIS DRAWING. WITHOUT OUR PRIOR CONSENT, IT IS NOT ALLOWED TO REPRODUCE, COPY, OR TRANSMIT THIS DRAWING IN ANY FORM OR BY ANY MEANS, ELECTRONIC OR MECHANICAL, INCLUDING PHOTOCOPYING, RECORDING, OR BY ANY INFORMATION STORAGE AND RETRIEVAL SYSTEM. IT IS ALSO NOT ALLOWED TO BE REPRODUCED OR TRANSMITTED IN ANY FORM OR BY ANY MEANS, ELECTRONIC OR MECHANICAL, INCLUDING PHOTOCOPYING, RECORDING, OR BY ANY INFORMATION STORAGE AND RETRIEVAL SYSTEM.