

样品承认书

SPECIFICATION FOR APPROVAL

型号 (Model) : KCD3-A1-101

品名 (Name) : 船形开关

ROCKER SWITCH

编制 Edit	审核 Check	批准 Approved	客户承认 C-Approved
方是亮	孙良忠	方家民	

	规 格 书 SPECIFICATION	编号 No.	
		日期 DATE	2012-01-11

1. 概述 GENERAL

- 1.1 系列 DESIGNATION: 船形开关 ROCKER SWITCH
 1.2 型号 MODULE No.: KCD3-A1-101
 1.3 电路图 CIRCUIT: 
 1.4 额定值 RATING: 16A 250VAC
 1.5 使用温度 OPERATING TEMPERATURE RANGE: 0 TO 55°C
 1.6 贮存温度 STORAGE TEMPERATURE RANGE: -20 TO 85°C

2. 外观与尺寸 APPEARANCE AND DIMENSIONS

- 2.1 外观 APPAERANCE: 无影响产品使用性能的缺陷。
 There shall be no defects that affect the serviceablity of the product.
- 2.2 标识 MARKING: 应有商标、型号、额定值、认证标志等标识。
 There shall be trademark, module No., rating, license mark and other necessary mark on the switch body.
- 2.3 尺寸 DIMENSIONS: 应符合产品图。
 Shall conform to drawing.

3. 性能要求 PERFORMANCE

项目 ITEM	测试条件 TEST CONDITIONS	要求 REQUIREMENT
3.1 电气性能 ELETRICAL PERFORMANCE:		
3.1.1 接触电阻 CONTACT RESISTANCE	开关处于闭合状态, 用微电阻测试仪或高精度线性毫欧计测量端子间的电阻 The switch to be made in "on" state, and the resistance be measured between the two terminals with micro-resistance test instrument or high precision liner mro-ohm meter.	50mΩ max
3.1.2 绝缘电阻 INSULATION RESISTANCE	触点间的绝缘和功能绝缘: 约500伏的直流电压施加在处于断开状态的开关的两触点间和开关的不同极之间, 相同极性的导电件应连接在一起。施加电压1分钟后进行测量 INSULATION RESISTANCE BETWEEN CONTACT AND OPERATIONAL INSULATION: A d.c. voltage of approximately 500V is applied between the open contacts of each pole of a switch and between the different poles of which all the parts is connected together, the measurement shall be made after the voltage is applied for 1 min.	10MΩ min
	加强绝缘: 约500伏的直流电压施加在导电部件和覆在易接触的开关外表面的金属箔及易接触的金属部件之间。施加电压1分钟后进行测量 REINFORED INSULATION: A d.c. voltage of approximately 500V is applied between all live parts and a metal foil covering the outer accessible surface and accessible metal parts, the measurement shall be made after the voltage is applied for 1 min.	100MΩ min
3.1.3 介电强度 DIELECTRIC STRENGTH	触点间和各极间的介电强度: 处于断开状态的开关的两触点间和开关的不同极之间, 应能承受基本为正弦波形, 频率为50或60赫兹的1500伏电压5秒钟无击穿或闪络现象。 DIELECTRIC STRENGTH BETWEEN CONTACTS AND BETWEEN	无击穿或闪络现象 No flashover or breakdown shall occur

规格书 SPECIFICATION

编号 No.

日期 DATE

2012-01-11

项目 ITEM	测试条件 TEST CONDITIONS	要求 REQUIREMENT
	<p>DIFFERENT POLES: A voltage of substantially sine wave form, with a frequency of 50Hz or 60Hz and the value of 1500v is applied for 5s between the open contacts and the different poles.</p> <p>加强绝缘间的介电强度: 基本为正弦波形的、频率为50或60赫兹、数值为3000伏的电压施加在导电部件和覆在开关的易接触外表面的金属箔及易接触的金属部件之间5秒钟无击穿或闪络现象发生。</p> <p>DIELECTRIC STRENGTH BETWEEN REINFORCED INSULATION: A voltage of substantially sine wave form, having a frequency of 50Hz or 60Hz and the value of 3000v is applied for 5s between all live parts and a metal foil covering the outer accessible surface and accessible metal parts.</p>	<p>无击穿或闪络现象 No flashover or breakdown shall occur</p>
<p>3.1.4 开关的发热 HEATING</p>	<p>开关首先在无电流通过的情况下,作20个操作循环,然后将操作件停留在最不利的“闭合”位置,开关通以电流,其值为电阻性负载最大额定电流的1.06倍,试验电流至少维持一小时或维持到端子温度稳定。当每隔5分钟读取连续的三个读数变化不大于±2℃,即认为温度稳定。测得的温升不应超过45K。</p> <p>First of all, the switches are subjected to 20 operating cycles with no current flowing. Then the actuating member is left in the most unfavourable "ON" position and the switches are loaded with a current of 1.06 times the maximum rated current for resistive load. The current is maintained at least for one hour or until a constant temperature at the terminal is attained. A temperature is considered to be constant when three successive readings obtained at every 5min of which value indicate no change greater than ±2℃.</p>	<p>端子温升不超过45K; 操作件温度不超过85℃; 金属操作件温度不超过60℃。 The temperature rise at the terminals shall not exceed 45K. The temperature of actuating members shall not exceed 85℃; Metal actuating members shall not exceed 60℃.</p>
<p>3.2 材料性能 MATERIAL PERFORMANCE:</p>		
<p>3.2.1 开关材料的阻燃性:灼热丝试验 RESISTANCE TO FIRE: GLOW WIRE TEST</p>	<p>保持、支持带电导体在其相对位置的非金属零件应能承受850℃的灼热丝试验,其他零件应能承受650℃的灼热丝试验。</p> <p>For nonmetal parts which are in contact with, maintain or retain the live parts in position should be carried out the glow wire test at the 850℃. The other parts should be carried out the glow wire test at the 650℃.</p>	<p>无火焰产生或灼热丝离开后火焰30秒内熄灭 No flame or the flame fire out in 30S when glow wire leave away.</p>
<p>3.2.2 开关材料的耐热性:球压试验 RESISTANCE TO HEAT: BALL PRESSURE TEST</p>	<p>保持、支持带电导体在其相对位置的非金属零件应能承受125℃的球压试验,其他零件应能承受75℃的球压试验。</p> <p>For nonmetal parts which are in contact with, maintain or retain the live parts in position electrical should be carried out the ball pressure test at the 125℃. The other parts should be carried out the ball pressure test at the 75℃.</p>	<p>压痕直径 ≤2mm The diameter of the impression shall not exceed 2 mm.</p>
<p>3.2.3 开关材料的耐漏电起痕特性 RESISTANCE TO TRACKING</p>	<p>在不同极的导电部件之间、导电部件与接地金属部件之间、导电部件与易接触的表面之间有特定的爬电路径的所有非金属部件应能通过175V的耐漏电起痕指数测试。</p> <p>All non-metal parts for which a creepage path is specified between live parts of different polarity,</p>	<p>No flashover or breakdown shall occur 无击穿或闪络现象</p>

	规 格 书 SPECIFICATION	编号 No.	
		日期 DATE	2012-01-11

项目 ITEM	测试条件 TEST CONDITIONS	要求 REQUIREMENT
	between live parts and earthed metal parts and between the live parts and accessible surfaces of a switch shall be carried out the proof tracking test of 175V.	

3.3 机械性能 MECHANICAL PERFORMANCE:

3.3.1 机械强度 MECHANICAL STRENGTH:	<p>将弹簧冲击器的释放能量校准到0.5Nm±0.04Nm,用弹簧冲击器对可触及的表面包括驱动元件进行冲击,对每一个认为薄弱的位置冲击三次。</p> <p>The spring-operated impact-test apparatus is calibrated to deliver an energy of 0.5Nm±0.04Nm Blows are applied to all accessible surfaces, including actuating members by the test apparatus. For all such surfaces three blows are applied to every point that is likely to be weak.</p> <p>首先对开关的按钮施加15N的拉力1分钟试图拉脱按钮,然后对所有按钮施加30N压力1分钟。</p> <p>First a pull of 15N shall be applied for 1 min to try to pull off the actuating member and secondly a push of 30N for 1 min is applied to all actuating member.</p>	<p>试验后不应有影响开关安全和使用的损伤。</p> <p>There shall be no damages to switch safety and usage</p>
3.3.2 操作性能 OPERATING PERFORMANCE:	<p>用约为20mm/s的线速度按动开关的按钮。</p> <p>The linear velocity is about 20mm/s while operating the switch actuator.</p>	

3.3.2 操作性能 OPERATING PERFORMANCE:	<p>用约为20mm/s的线速度按动开关的按钮。</p> <p>The linear velocity is about 20mm/s while operating the switch actuator.</p>	<p>当释放按钮时,开关只能处于“闭合”或“断开”的状态。</p> <p>When release the actuator, the switch is in "open" or "close" status.</p>
--------------------------------------	--------------------------------------------------------------------------------------------------------------	----------------------------------------------------------------------------------------------------------------

3.3.3 插片端子的安装强度 THE STRENGTH OF TABS:	<p>将80N的轴向压力和98N的轴向拉力依次无冲击地作用在开关的插片上。</p> <p>A axial push of 80N and a axial pull of 98N shall be applied in turn to the tabs of a switch without jerks.</p>	<p>开关的插片不应出现明显的位移和损伤。</p> <p>No significant displacement or damage shall occur.</p>
------------------------------------------	--------------------------------------------------------------------------------------------------------------------------------------------------------------	-------------------------------------------------------------------------------------

3.4 耐久性能 ENDURANCE:

3.4.1 提高电压加速测试 INCREASE-VOLTAGE AT ACCELERATED SPEED:	<p>测试电压 APPLIED VOLTAGE: 1.15倍额定电压 1.15 times of rated voltage</p> <p>测试电流 APPLIED CURRENT: 额定电流 Rated current</p> <p>操作循环数: THE NUMBER OF OPERATING CYCLE: 100</p> <p>功率因数 POWER FACTOR : 0.95±0.05</p> <p>环境温度 AMBIENT TEMPERATURE: 25±10℃</p> <p>操作速率 OPERATING RATE: 15次/分钟 15 operations per minute</p>	<p>1、所有的动作功能正常。</p> <p>2、通以额定电流,在周围温度为25±10℃的条件下进行温升测试,端子温升不应超过55K。</p> <p>3、能够承受3.1.3条要求的75%的介电强度测试。</p> <p>1.All actions function as normal;</p> <p>2.The temperature rise test at the terminal carried out under rated current and ambient temperature of 25±10℃.</p> <p>the temperature rise at</p>
----------------------------------------------------------	--------------------------------------------------------------------------------------------------------------------------------------------------------------------------------------------------------------------------------------------------------------------------------------------------------------------------------------	---------------------------------------------------------------------------------------------------------------------------------------------------------------------------------------------------------------------------------------------------------------------------------------------------------

	规 格 书 SPECIFICATION	编号 No.	
		日期 DATE	2012-01-11

项目 ITEM	测试条件 TEST CONDITIONS	要求 REQUIREMENT
	操作速度 OPERATING SPEED: 大约80mm/s的线性速度 Approximately 80mm/s for lineal actions	the terminal does not exceed 55K. 3.Can subject to the dielectric strength test which the test voltage shall be 75% the corresponding test voltage specified in clause 3.1.3.
3.4.2慢速测试 SLOW SPEED TEST:	测试电压 APPLIED VOLTAGE: 额定电压 rated voltage 测试电流 APPLIED CURRENT: 额定电流 Rate current 操作循环数: THE NUMBER OF OPRATING CYCLE: 100 功率因数 POWER FACTOR : 0.95±0.05 环境温度 AMBIENT TEMPERATURE: 25±10℃ 操作速率 OPERATING RATE: 15次/分钟 15 operations per minute 操作速度 OPERATING SPEED: 大约20mm/s的线性速度 Approximately 20mm/s for lineal actions	
3.4.3加速测试 ACCELERATED SPEED TEST:	测试电压 APPLIED VOLTAGE: 额定电压 rated voltage 测试电流 APPLIED CURRENT: 额定电流 Rate current 操作循环数: THE NUMBER OF OPRATING CYCLE: 9800 功率因数 POWER FACTOR : 0.95±0.05 环境温度 AMBIENT TEMPERATURE: 25±10℃ 操作速率 THE RATE OF OPERATIONS: 15次/分钟 15 operations per minute 操作速度 OPERATING SPEED: 大约80mm/s的线性速度 Approximately 80mm/s for lineal actions	
3.5 焊接性能 SOLDERING PERFORMANCE:		
3.5.1可焊性试验 SOLDERING TEST:	端子顶部被浸入焊锡池中2mm深, 温度230±5℃, 时间3秒。 The tip of the terminal shall be dipped 2mm in the bath at temperature 230±5℃ for 3 sec.	浸入的部分75%以上表面将被锡覆盖。 A new uniform coating of solder shall cover a minimum of 75% of the surface being immersed.
3.5.2耐焊接热试验 RESISTANCE TO SOLDERING HEAT TEST:	焊锡炉的方法: 焊锡炉的温度控制在260℃±5℃, 锅炉焊接的时间3±0.5秒, 基板的厚度为1.6mm。 SOLDER BATH MOTHOD: Solder temperature 260℃±5℃; Immersion time 3±0.5sec.	本体无变形, 能满足机械、电气性能要求。 Without distoration of case or excessive looseness of terminals, Electrial and mechanical characteristics

	规 格 书 SPECIFICATION	编号 No.	
		日期 DATE	2012-01-11

项目 ITEM	测试条件 TEST CONDITIONS	要求 REQUIREMENT
	<p>the thickness of PCB 1.6mm.</p> <p>手工焊接方法： 手工焊接的时候，温度控制在350℃±5℃，焊接的时间3±0.5秒，但不能在端子上施加异常力。 SOLDERING IRON MOTHOD: Control temperature 260℃±5℃; Application time 3±0.5sec; However excessive pressure shall not be applied to the terminal.</p>	shall be satisfied.

4、开关的材料 MATERIALS OF THE SWITCH

零件名称 PARTS	材料名称 MATERIAL	供应商 MANUFACTURER
基座 (Base)	增强阻燃尼龙 PA66-B10	横店得邦工程塑料有限公司 Hengdian Debang CO., LTD
按钮 (Push button)	聚碳酸脂 PC1250	日本帝人工程塑料有限公司 Ribem Diren CO., LTD
内套 (Inner sheathing)	阻燃尼龙 FYR27T03	河南神马 Henan shenma
接触桥 (Contact bridge)	紫铜带 T2 Copper Strip	万泰铜业公司 WaitaiCopper CO., LTD
端子 (Terminal)	紫铜带 T2 Copper Strip	万泰铜业公司 WaitaiCopper CO., LTD
触点 (Contact bridge)	AgNi10/Cu	福达合金材料公司 FudaAlloyMaterial CO., LTD
弹簧 (Spring)	碳素弹簧钢丝 Steel Wire	新达电子元件厂 XindaElectronicComponent CO., LTD

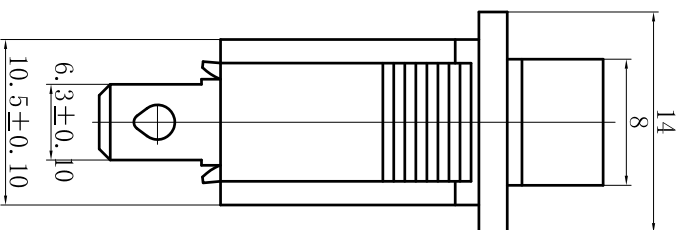
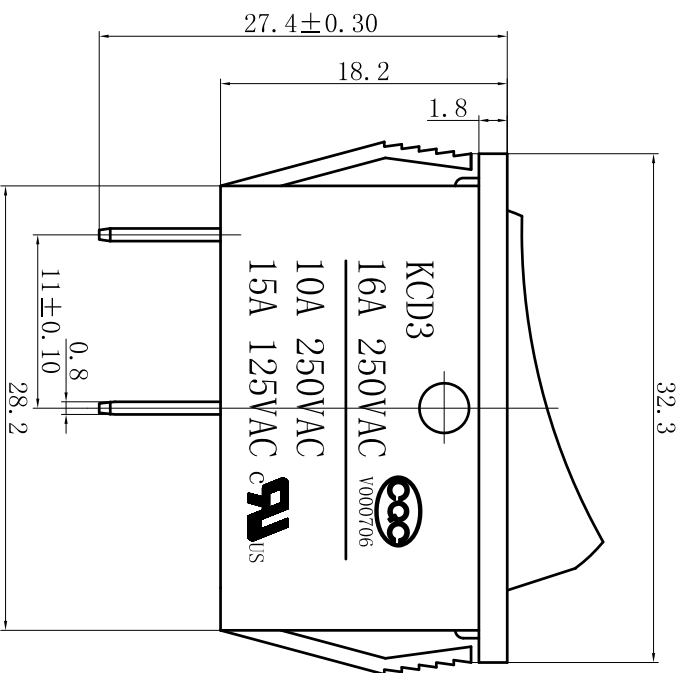

主要技术参数、性能 The Main Technology Performance

项目 Item	参数 Parameter
电路图 Circuit	ON-OFF
额定电流、电压 Rated voltage Rated current	16A 250V AC (16/100A 250V AC)
绝缘电阻 Insulated resistance	≥100MΩ
接触电阻 Contact resistance	≤50mΩ
介电强度(工作绝缘) Dielectric strength	≥1500V/5s
电气寿命 使用温度 Ambient temperature	≥10000 T55

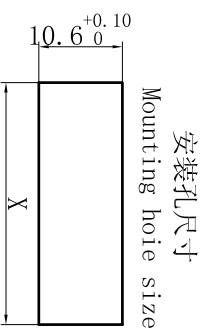
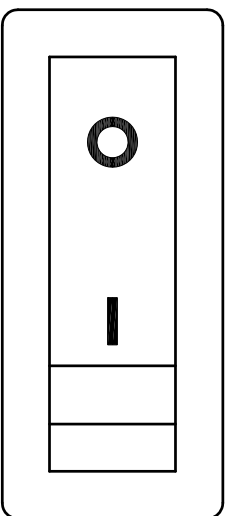

安装面板厚度 Install panel thickness	X
1.5~2.5	30.7

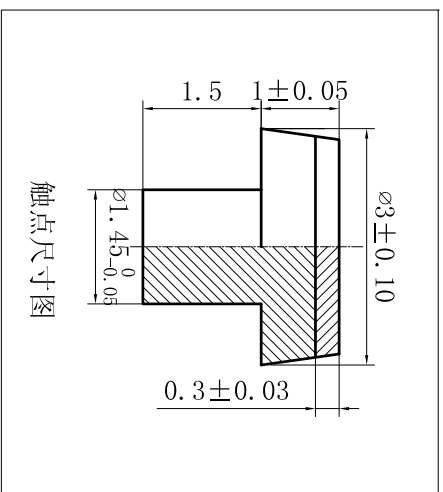

触点尺寸图

标记	数量	更改文件号	更改人	日期
MARK	AMOUNT	MODIFY FILE NO.	CHANGE BY	DATE
设计	DESTIGN			
审核	CHECK			
批准	APPROVAL			
			日期	DATE
第一视角 THE FIRST ANGLE PROJECTION		比例 SCALE 2:1		
		一般公差 GENERAL TOLERANCE		
单位 UNIT	mm	>0.5~6	±0.10	
重量 WEIGHT		>6~30	±0.20	
角度 ANGLE		>30~120	±0.30	
		角度 ANGLE	±2°	
KCD3-1-101011CBD		船形开关 ROCKER SWITCHES		
DESIGNATION: KCD3-A1-101				