

Outline Dimensions

Part No. : LD504W3CD-2B/02

§ Standard 5mm diameter package.

Characters

§ High intensity.

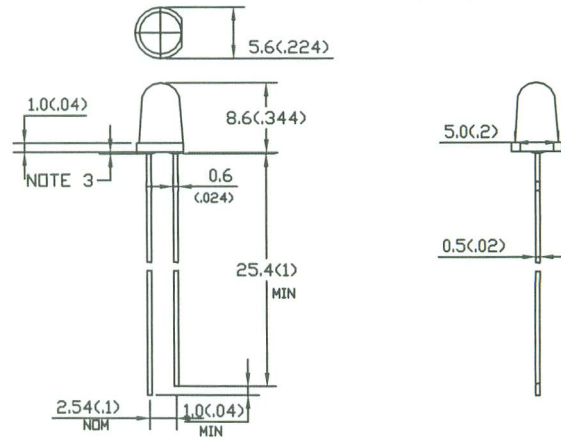

§ All dimensions are in millimeters (inches) .

§ Tolerance is ± 0.25 (.010) mm unless otherwise noted.

§ Protruded resin under flange is 1.0 mm (.04) max.

ITEM		MATERIALS
Resin(Mold)		Epoxy
Lens Color Code	C	Water Transparent
	T	Colored Transparent
	M	White Diffused
	D	Colored Diffused
Lead Frame		Ag Plating Iron Alloy
Dice		InGaN

Absolute Maximum Ratings (Ta=25°C)

Item	Symbol	Value	Unit
Power Dissipation	PD	120	mW
DC Forward Current	IF	30	mA
Pulsed Forward Current	IFP	100*	mA
Reverse Voltage	VR	5	V
Operating Temperature	Topr	-25 ~ +80	°C
Storage Temperature	Tstg	-40 ~ +100	°C
Soldering Temperature	Tsol	260for5sec	°C

* Duty 1/10 Pulse Width 0.1ms Δ At the position of 4mm from the bottom of the package

Directive Characteristics (Ta=25°C)

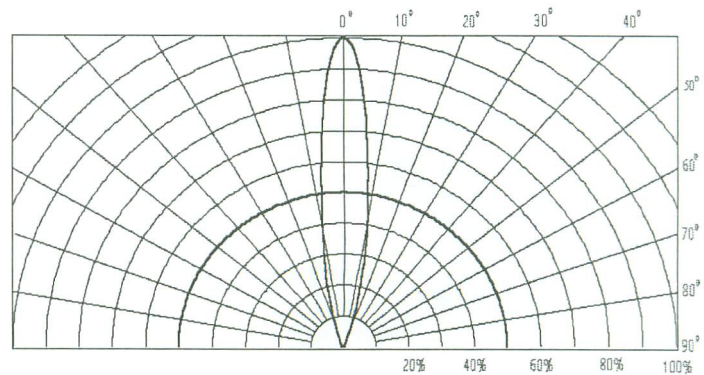

Electrical-Optical Characteristics (Ta=25°C)

Parameter	Symbol	Value			Unit	Test condition
		Min.	Typ.	Max.		
Forward Voltage	V_f	---	3.2	4.0	V	$I_f=20\text{mA}$
Luminous intensity	I_v	12000	15000	---	mcd	$I_f=20\text{mA}$
Wavelength	$x(\& \lambda d)$	---	0.2793	---	(nm)	$I_f=20\text{mA}$
	y	---	0.2600	---	---	$I_f=20\text{mA}$
Reverse Current	I_r	---	---	1	μA	$V_r=5\text{V}$
Viewing angle	$2\theta_{1/2}$	---	20	---	Deg	$I_f=20\text{mA}$
Spectral half bandwidth	$\Delta \lambda$	---	---	---	nm	$I_f=20\text{mA}$