

SPECIFICATIONS

CA845-01-01C

ITEMS		MODEL	CME200A-12	CME200A-18	CME200A-24	CME200A-36	CME200A-48
1	Nominal Output Voltage	V	12	18	24	36	48
2	Maximum Output Current @ Convection cooling	A	16.7	11.2	8.4	5.5	4.2
	Maximum Output Current @ Forced air cooling	(*12) A	16.7	14.0	10.5	7.0	5.3
3	Maximum Output Power @ Convection cooling	W	200.4	201.6	201.6	198.0	201.6
	Maximum Output Power @ Forced air cooling	(*12) W	200.4	252.0	252.0	252.0	254.4
4	Standby Mode Power	-	5V @ 0.5A(max)				
5	Efficiency @ Convection cooling (Typ.)	(*1) %	92 / 93	92 / 94	92 / 94	92 / 94	92 / 94
	Efficiency @ Forced air cooling (Typ.)	(*1) %	92 / 93	92 / 94	92 / 94	92 / 94	92 / 94
6	Input Voltage Range	(*2) -	85 - 265 VAC (47-63Hz)				
7	Input Current @ Convection cooling (Typ.)	(*1) A	2.2/ 1.1				
	Input Current @ Forced air cooling (Typ.)	(*1) A	3.0/ 1.5				
8	In-rush Current (Typ.)	(*1)(*3) -	35A / 70A at Cold Start				
9	PFHC	-	Built to meet IEC61000-3-2,Class A				
10	Power Factor (Typ.)	(*1) -	0.99/0.95				
11	Output Voltage Range	V	11.7 ~ 12.6	17.6 ~ 18.9	23.5 ~ 25.2	35.2 ~ 37.8	47 ~ 50.4
12	Maximum Ripple & Noise@ Convection cooling	(*1)(*4)(*5) mV	180	180	240	360	480
	Maximum Ripple & Noise@ Forced air cooling	(*1)(*4)(*5) mV	180	200	240	360	480
13	Maximum Line Regulation	(*4)(*6) mV	60	90	120	180	240
14	Maximum Load Regulation	(*4)(*7) mV	120	180	240	360	480
15	Power Consumption @ Remote OFF(Typ.)	(*13) -	< 0.5W @ 230VAC				
16	Temperature Coefficient	(*4) -	Less than 0.02% / °C				
17	Over Current Protection	(*8) A	>17.5	>14.7	> 11	>7.4	>5.5
18	Over Voltage Protection	(*9) V	13.2 - 16.2	19.8 - 24.3	26.4 - 32.4	39.6 - 48.6	52.8 - 64.8
19	Hold-up time (Typ.)	(*1) -	16ms @ 200W, 12ms @ 250W				
20	Leakage Current	(*10) -	0.3mA max @ 265VAC, 60Hz				
21	Remote ON/OFF control	-	Possible				
22	DC-OK	-	Possible				
23	Parallel Operation	-	-				
24	Series Operation	-	Possible				
25	Operating Temperature	(*11) -	-20°C - +70°C				
26	Operating Humidity	-	10 - 95%RH (No condensing)				
27	Storage Temperature	-	-40°C - +85°C				
28	Storage Humidity	-	10 - 95%RH (No condensing)				
29	Cooling	(*12) -	Convection or Forced Air Cooling				
30	Withstand Voltage	-	Input-FG : 2kVAC (20mA) 1x MOPP Input-Output : 4kVAC (20mA) 2x MOPP Output-FG : 1.5kVAC (20mA) 1x MOPP				
31	Isolation Resistance	-	More than 100MΩ at 25°C,70%RH, Output - FG : 500VDC				
32	Vibration	-	At no operating, 10-55Hz (Sweep for 1min.) Maximum 19.6m/s ² X,Y,Z 1 hour each				
33	Shock	-	Less than 196m/s ² and MIL-STD-810F				
34	Safety	-	Approved by IEC/EN62368-1,UL62368-1,CSA62368-1 Approved by IEC/EN60601-1,ES60601-1,CSA-C22.2 No.60601-1				
35	EMI	(*1) -	Designed to meet EN55011-B, EN55032-B, FCC-Class B				
36	Immunity	-	Designed to meet IEC61000-6-2 IEC61000-4-2, IEC61000-4-3, IEC61000-4-4, IEC61000-4-5 IEC61000-4-6, IEC61000-4-8, IEC61000-4-11				
37	Weight (Typ.)	g	350				
38	Size (L x W x H)	mm	127 x 76.2 x 34 (Refer to Outline Drawing)				

*Read instruction manual carefully, before using the power supply unit.

=NOTES=

*1. At 115VAC/230VAC, Ta=25°C, Nominal output voltage and maximum output power.

*2. For cases where conformance to various safety specs (UL, CSA, EN) are required, input voltage range will be 100 ~ 240VAC (50-60Hz).

Output derating required when Vin is less than 115VAC, refer to output derating curve for details.

*3. Not applicable for the in-rush current to Noise Filter for less than 0.2ms.

*4. Please refer to Fig. A for measurement of Vo, line and load regulation and ripple voltage.

*5. Ripple & noise are measured at 20MHz by using a 150mm twisted pair of load wires terminated with a 0.1uF and 100uF capacitor.

*6. 85~265VAC, constant load.

*7. No load - full load, constant input voltage.

*8. Hiccup with automatic recovery, however power supply may be latched for protection when output is shorted and manual reset is required (Repower on).

Avoid to operate at over load or short circuit condition.

*9. OVP circuit shut down the output, manual reset (Repower on) to get output voltage.

*10. Measured by the each measuring method of UL, CSA, and EN (at 60Hz), Ta=25°C.

*11. Refer to output derating curve for details of output derating versus

input voltage, ambient temperature and mounting method.

- Load (%) is percent of maximum output power or maximum output current.

- Do not exceed its derating of Maximum Load.

*12. Forced air cooling with air velocity more than 1.5m/s (measured at component side, The entire components must be cooled).

*13. The power consumption refers to input power during remote off and standby mode power is at no load condition.

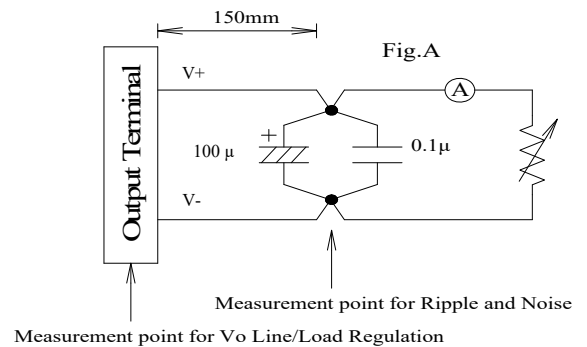

OUTPUT DERATING

CA845-01-02A

OUTPUT DERATING VERSUS OPERATING AMBIENT TEMPERATURE (Ta)

*COOLING : CONVECTION COOLING

MODEL: CME200A-18, CME200A-24, CME200A-36, CME200A-48

Ta (°C)	MOUNTING A,B	MOUNTING C,D	MOUNTING E
	LOAD (%)	LOAD (%)	LOAD (%)
-20 - +40	100	100	100
50	100	80	100
60	75	60	75
65	63	50	-
70	50	40	-

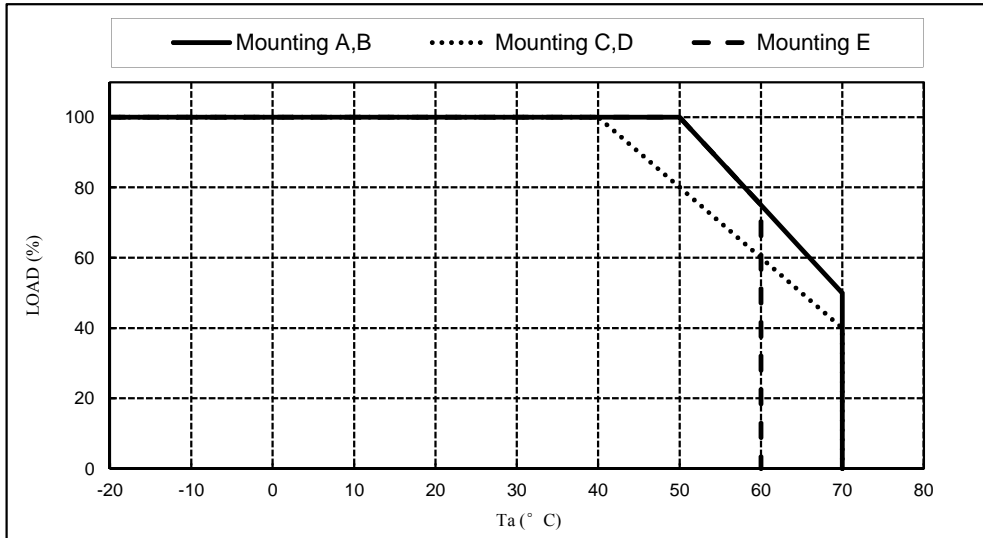

*COOLING : CONVECTION COOLING

MODEL: CME200A-12

Ta (°C)	MOUNTING A,B	MOUNTING C,D	MOUNTING E
	LOAD (%)	LOAD (%)	LOAD (%)
-20 - +40	100	100	100
50	100	80	80
60	75	60	60
65	63	50	-
70	50	40	-

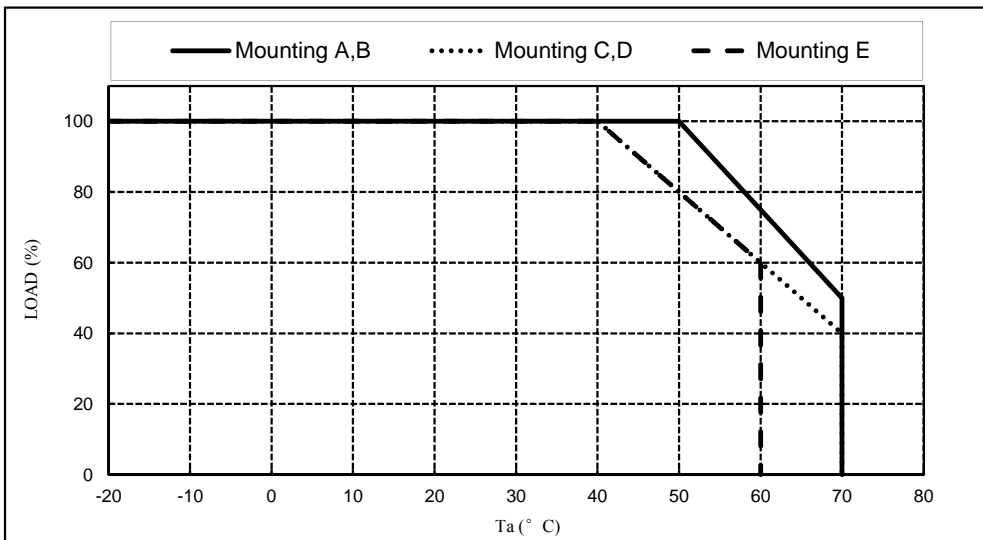

OUTPUT DERATING

CA845-01-03A

OUTPUT DERATING VERSUS OPERATING AMBIENT TEMPERATURE (Ta)

* COOLING: FORCED AIR COOLING
FOR ALL MOUNTINGS AND ALL MODELS

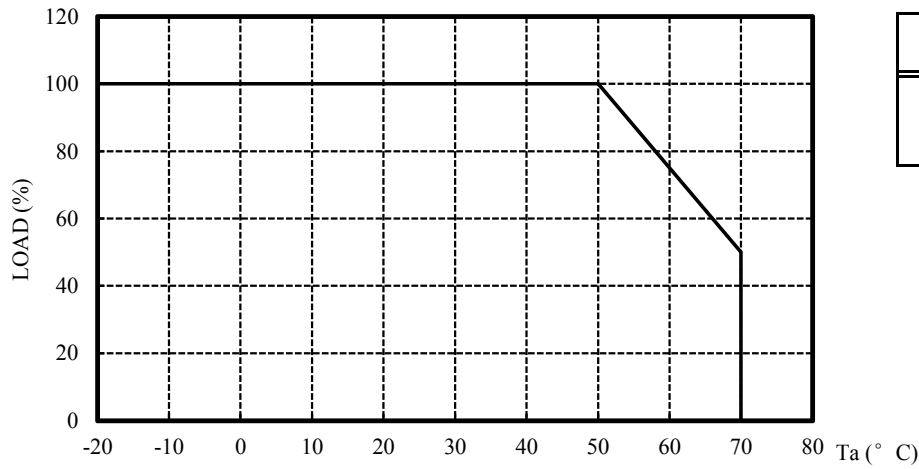

Ta (°C)	LOAD (%)
-20 - +50	100
60	75
70	50

OUTPUT DERATING VERSUS INPUT VOLTAGE

FOR ALL MOUNTINGS AND ALL MODELS

INPUT VOLTAGE (VAC)	LOAD (%)
85	80
115~265	100

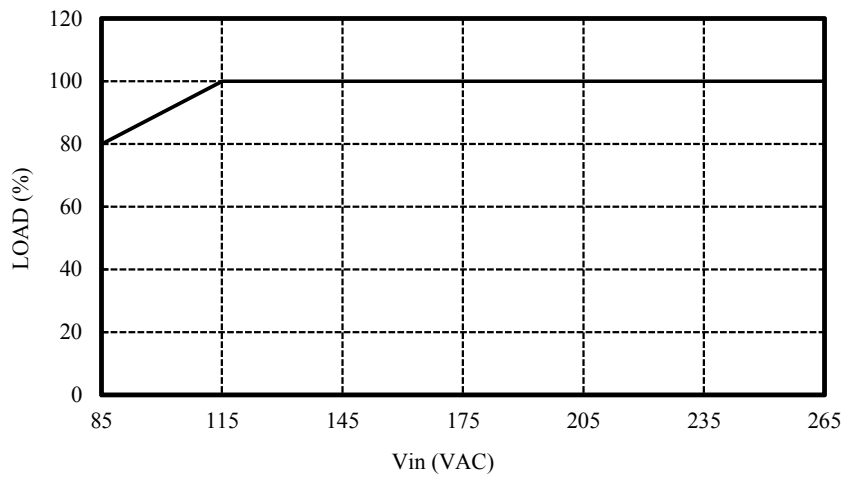

MOUNTING METHOD

