

**Part Number: MMPSA 240/30 (Alternate Part No: S1693) LH**  
**Proximity Switch - Reed Switch based**  
**Rectangular - Normally Open Contacts - Suggested Magnet: MMPSM**

**PICTURE**



✓ **RoHS Compliant**

**APPLICATIONS INCLUDE**

- Position and limit sensing
- Linear actuators
- Security system switch
- Door Switch

**FEATURES**

- Also available in all Black.
- White economy version available.
- Left (**MMPSA 240/30 LH**) and Right (**MMPSA 240/30 RH**) hand versions available.
- Custom cable lengths, strip lengths, cable types, terminations.
- If you do not see what you need, just ask, as there is a strong possibility we can do it!
- Device is intended to be mounted in an enclosure under UL recognition.

**DIMENSIONS**

Drawings not to scale.  
 All dimensions in mm (inches) nominal.

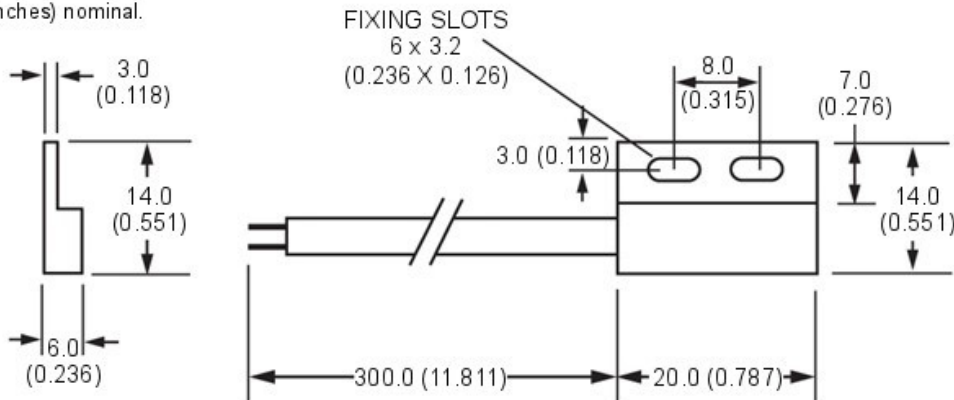

**SPECIFICATION**

Contact Form / Style	Normally Open
Switching Capacity (Resistive)	10 W/VA MAX
Switching Voltage	350 VAC MAX
Switching Current	0.5 A MAX
Carry Current	1.0 A MAX
Breakdown Voltage	600 VDC MIN (reed switch reference value)
Contact Resistance	150 mOhms MAX
Switching Distance	10 mm MIN
Operating Temperature Range	-20°C +85°C
Storage Temperature	-25°C +90°C
Case Material	Blue Nylon 66
Cable	2 x Round 0.14mm <sup>2</sup> PVC covered Grey and insulated Brown/White

As part of the company policy of continued product improvement, specifications may change without notice. Our sales office will be pleased to help you with the latest information on this product range and the details of our full design and manufacturing service. All products are supplied to our standard conditions of sale unless otherwise agreed in writing.

**Phone: (1) 973 777 6900**      **www.comus-intl.com**      **Fax: (1) 973 777 8405**