

Frontplattenausschnitt (Rueckseite)
Panel cut out (rear side)

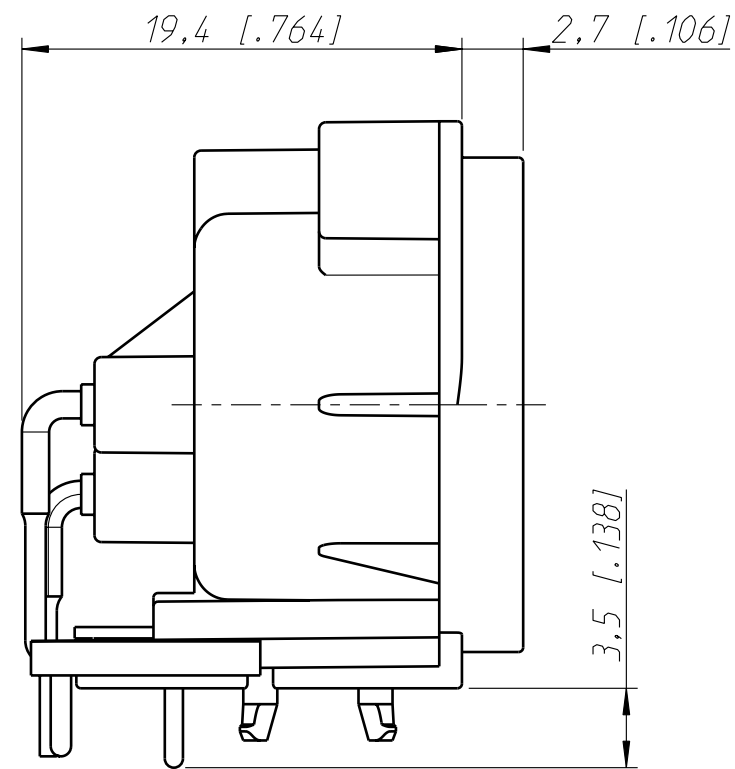

Print Bohrplan (Bestueckungsseite)
PCB-Layout (component side)

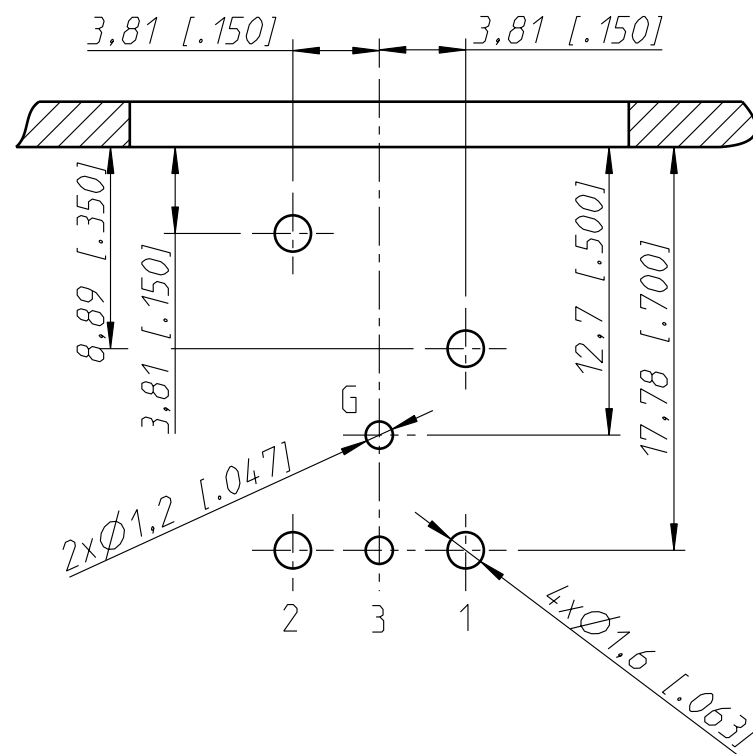
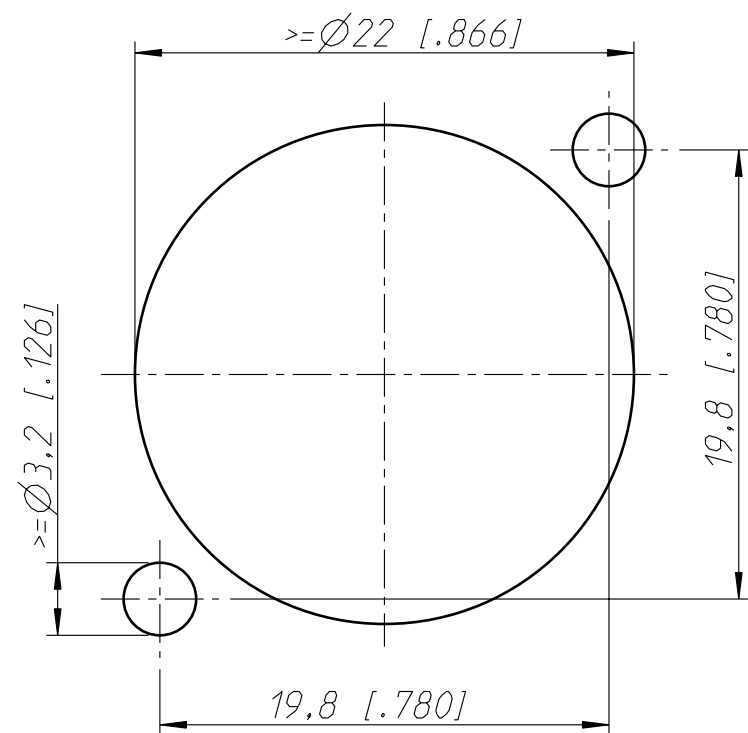
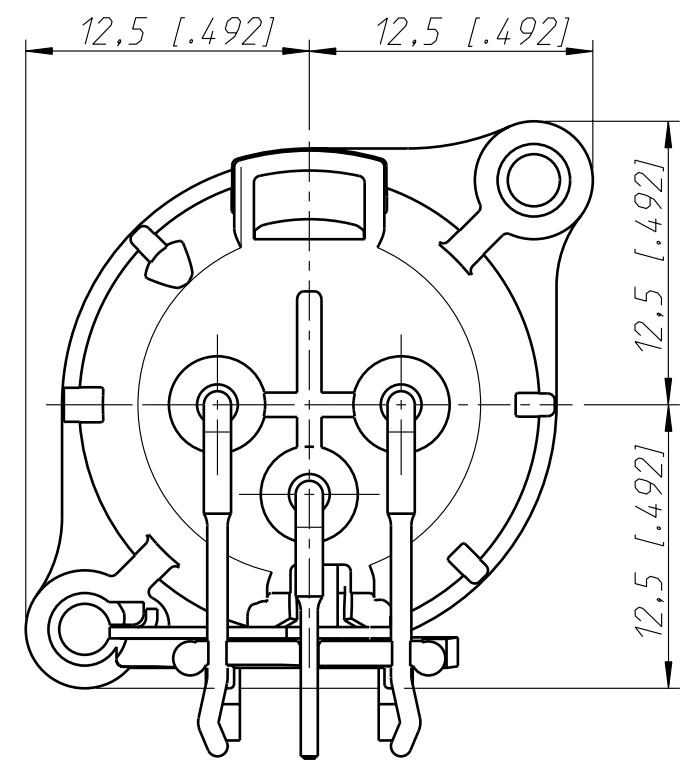

Housing material: UL94 V-0

Allgemeintoleranzen ISO 2768-m	Werkstoff	Massstab:	Datum	Name
Zeichnung urheberrechtlich geschuetzt (DIN 34) (C)	-	3:1 (A3)	Gezeichnet	21.12.93 Dobler
			Freigegeben	
Benennung	NC3MAH NC3MAH	NEUTRIK AG FL-9494 SCHAAN	Geändert	28.05.08 Mijatovic
			Aend.-Nr.	-
			Ersatz fuer:	Blatt 1 von 1 Bl.
			Zeichn. Nr.	ST-NC3MAH