

## 300/400MHz BAND DOWN MIXER WITH AMPLIFIER

### ■ GENERAL DESCRIPTION

The **NJM2288** is a low-current, low-voltage down mixer, which operates from 2V supply. It is very suitable for situations where small size, low cost, low parts count is important.

### ■ PACKAGE OUTLINE

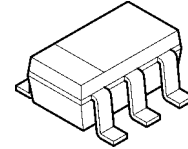

**NJM2288F1**

### ■ FEATURES

- Wide Operating Voltage                    2V to 5.5V
- Low Operating Current                    2.8mA type. @ V+=2.2V, 429MHz input
- Conversion Gain                            9dB @V+=2.2V, 429MHz input
- Input Frequency                            300MHz to Up to 500MHz (recommended range)
- Excellent Thermal Stability  
     Conversion Gain                    2dB @ V+=2.2V, 429MHz input, - 40 to + 85°C (reference range)
- Third - Order Intercept Point            -12dBm @V+=2.2V, 429MHz input
- Local Input Resistance                   9.1kΩ
- Bipolar Technology
- Package Outline                            SOT23-6 (MTP6), 2.8mm x 2.9mm

### ■ PIN CONFIGURATION

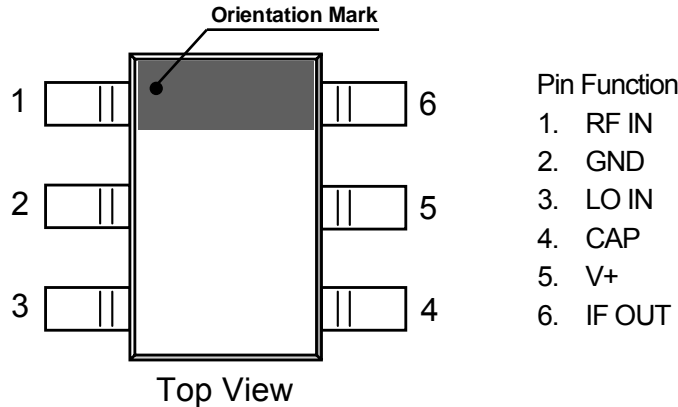

### ■ Simplified Block Diagram

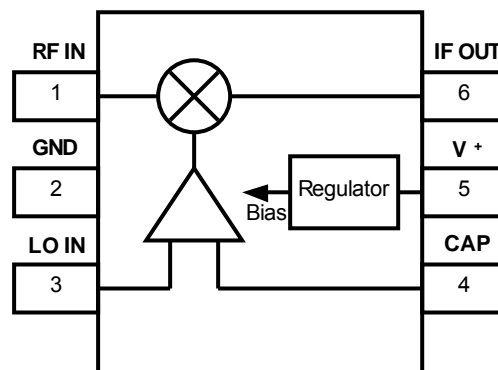

**■ ABSOLUTE MAXIMUM RATINGS (Ta=25°C)**

PARAMETER	SYMBOL	RATINGS	UNIT
Supply Voltage	V+	7	V
Power Dissipation	P <sub>D</sub>	200	mW
RF Input Level	Pr f max	6	dBm
LO Input Level	Pl o max	6	dBm
Operating Temperature	T o p r	- 40 to + 85	°C
Storage Temperature	T s t g	- 40 to +125	°C

**■ RECOMMENDED OPERATING CONDITIONS (Ta=25°C)**

PARAMETER	SYMBOL	TEST CONDITIONS	MIN.	TYP.	MAX.	UNIT
Supply Voltage	V+		2	2.2	5.5	V

**■ ELECTRICAL CHARACTERISTICS**

Ta=25°C, V+ =2.2V, frf = 429MHz, Prf = -35dBm, flo = 407.7MHz, Plo = -15dBm, fif = 21.3MHz, unless otherwise noted)

PARAMETER	SYMBOL	TEST CONDITIONS	MIN.	TYP.	MAX.	UNIT
Operating Current	I c c q	No signal Test circuit 1	-	2.8	3.5	mA
Conversion Gain	CG	Test circuit 1	-	9	-	dB
Mixer Intercept Point	IIP3	Test circuit 1	-	- 12	-	dBm
Noise Figure	NF	Test Circuit 2	-	9	-	dB
RF Input Return Loss	S <sub>11</sub>   <sup>2</sup>	Test Circuit 3	-	- 0.8	-	dB
Impedance between LO IN and CAP Terminal	Zlo	Test Circuit 4 DC value	-	9.1	-	kΩ
LO Leakage at RF IN (1)	Plo-rf1	Test Circuit 3	-	- 40	-	dB
LO Leakage at RF IN (2)	Plo-rf2	Test Circui3 flo=800MHz, Plo= -15dBm	-	- 25	-	dB
LO Leakage at IF OUT	Plo-if	Test Circuit1	-	- 40	-	dB

**■ TEMPERATURE DRIFT (Reference)**

PARAMETER	SYMBOL	TEST CONDITIONS	MIN.	TYP.	MAX.	UNIT
Conversion Gain	--	Ta= - 40 to + 85°C	- 2	0	2	dB

■ TEST CIRCUIT

These test circuits allow the measurement of all parameters described in "ELECTRICAL CHARACTERISTICS".

● Test Circuit 1 for Iccq, CG, IIP3 and Plo-if

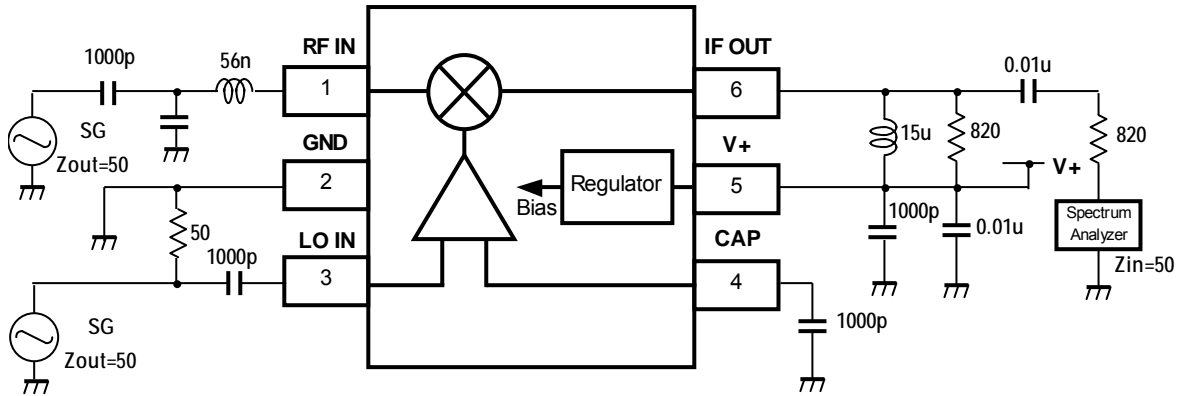

CG is calculated from

$$CG = P_{if} - P_{rf}$$

Where

$P_{sa}$  = the value of spectrum analyzer in dBm

$$P_{if} = P_{sa} + 10 \log 820/50 \text{ (dBm)}$$

$P_{rf}$  = input level in dBm

● Test Circuit 2 for NF

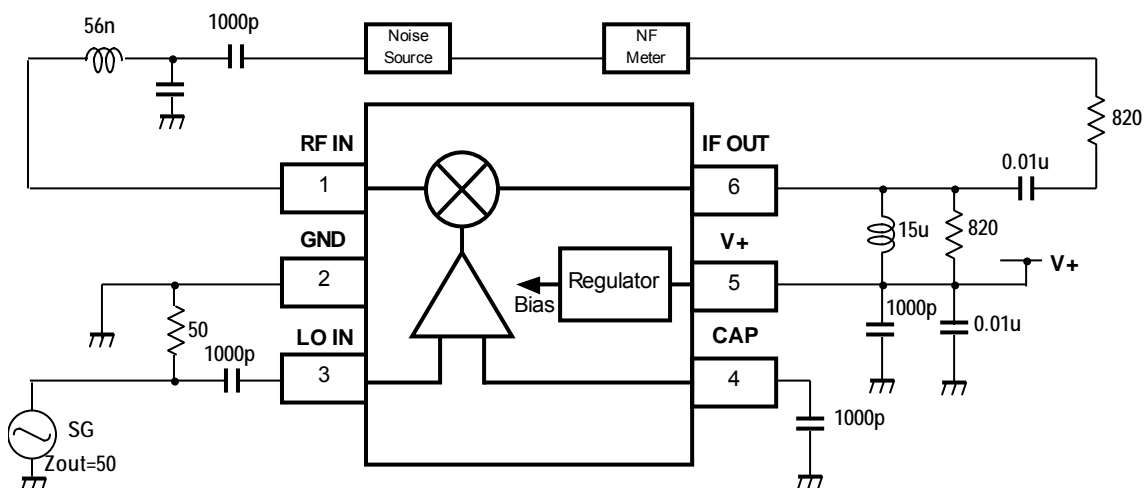

● Test Circuit 3 for IS11I<sup>2</sup>, Plo-rf1 and Plo-rf2

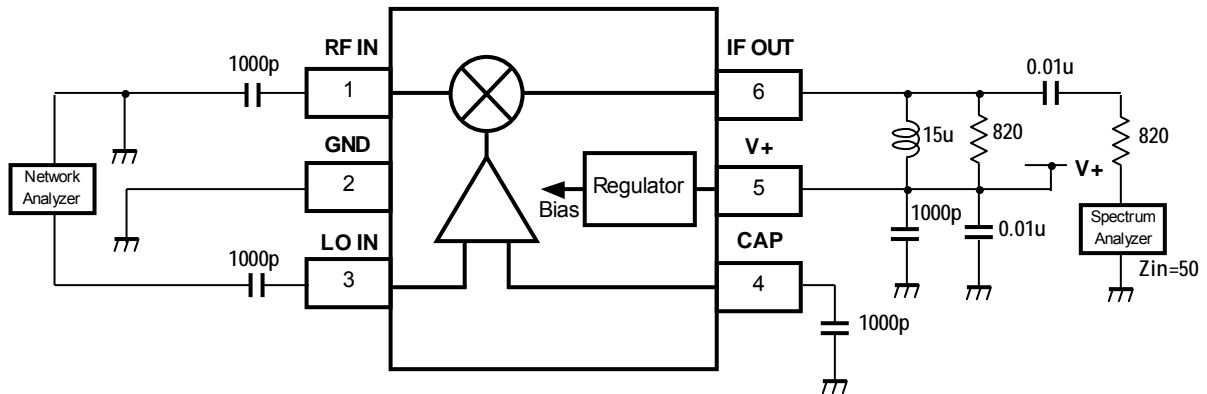

● Test Circuit 4 for Zlo

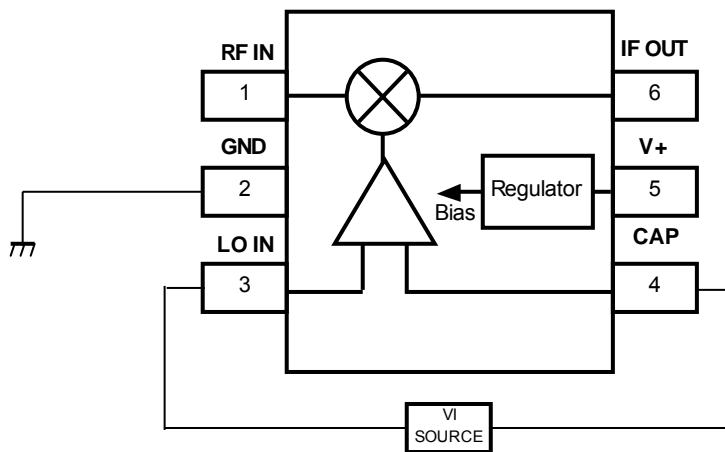

● Test Circuit 5 for VCG (voltage conversion gain)

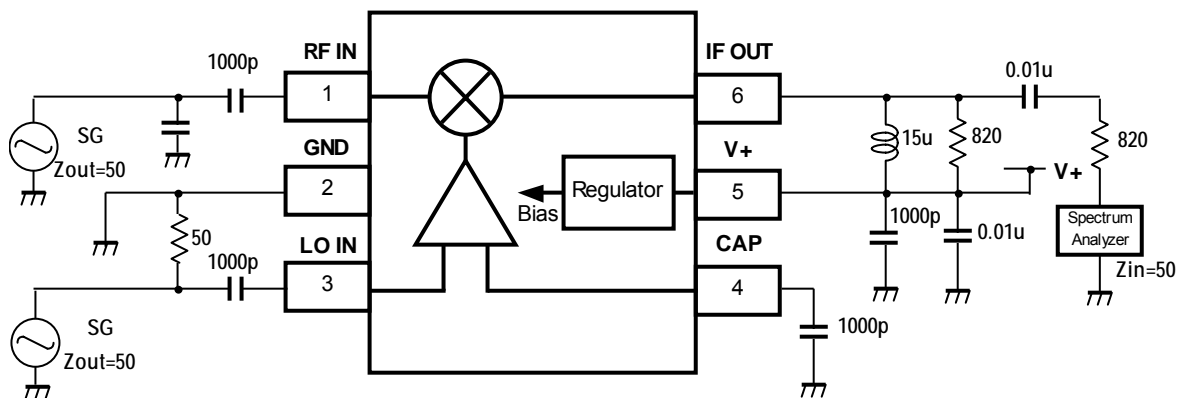

■ EVALUATION PC BOARD

The evaluation board is useful for your design and to have more understanding of the usage and performance of this device. This circuit is the same as TEST CIRCUIT. Note that this board is not prepared to show the recommendation of pattern and parts layout.

● Circuit Diagram

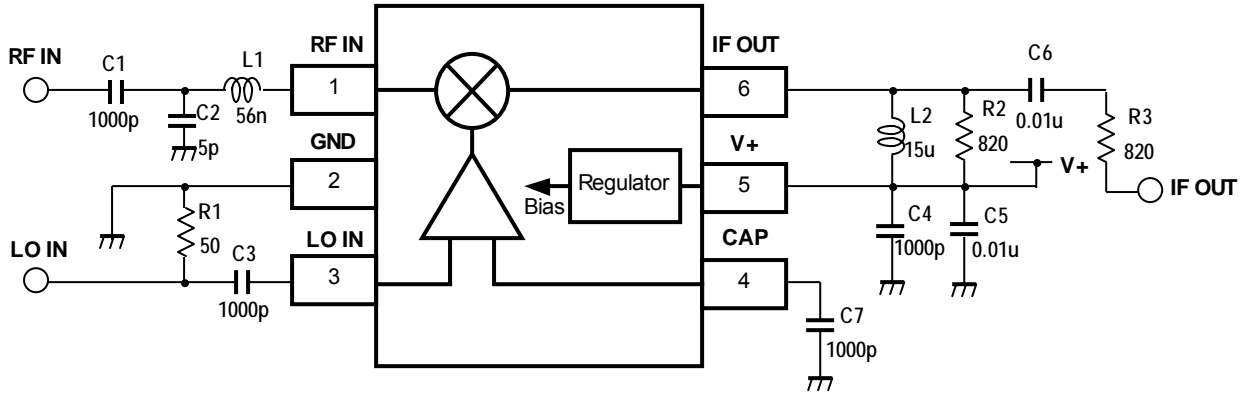

● Evaluation PC Board

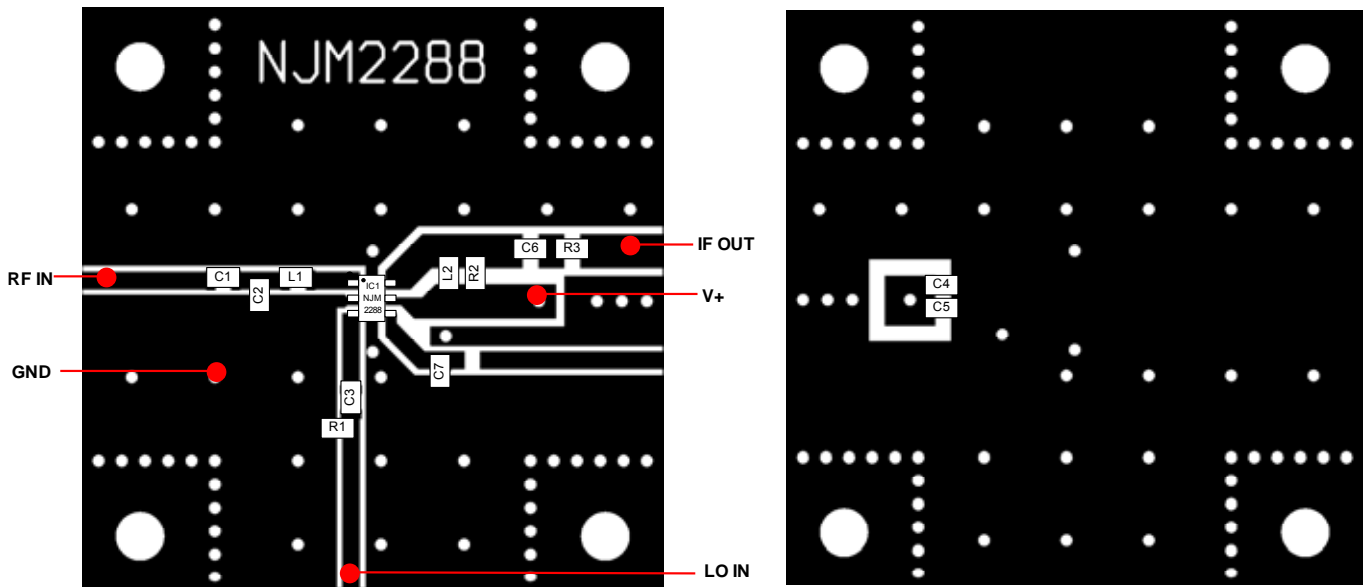

● External Components

Number	Value	Supplier	Number	Value	Supplier
IC1	NJM2288	New Japan Radio	C1	1000pF	Murata (GRM21 series)
			C2	5pF	Murata (GRM21 series)
R1	50Ω	KOA (RK73B series)	C3	1000pF	Murata (GRM21 series)
R2	820Ω	KOA (RK73B series)	C4	1000pH	Murata (GRM21 series)
R3	820Ω	KOA (RK73B series)	C5	0.01uF	Murata (GRM21 series)
			C6	0.01uF	Murata (GRM21 series)
L1	56nH	Taiyo Yuden (HK1608)	C7	1000pF	Murata (GRM21 series)
L2	15uH	Taiyo Yuden (LAP02)			

## ■ TERMINAL FUNCTION (Ta=25°C, V+=2.2 V)

Pin No.	SYMBOL	EQUIVALENT CIRCUIT	VOLTAGE	FUNCTION
1	RF IN		1.18V	<b>RF Input</b> Recommended input frequency range is from 300 to 500MHz. For using at another frequency, please refer to the data shown in "TYPICAL CHARACTERISTICS".
6	IF OUT		--	<b>IF Output</b> Output frequency $f_{if}$ is calculated from $f_{if} = f_{rf} - f_{lo}$ . where $f_{rf}$ =RF IN input signal frequency $f_{lo}$ =LO IN input signal frequency
2	GND	--	--	<b>Ground</b>
3	LO IN		2.03V	<b>Local Input</b> Input level of over -20dBm is recommended to obtain high IF output level, where IF output is saturated. Note that absolute maximum input level is 6dBm.
4	CAP		2.03V	<b>Local Signal Reverse Input</b> An external decoupling capacitor is placed between this pin and ground. The value of capacitance should be selected to be very low impedance at LO IN input signal frequency.
5	V+	--	--	<b>Supply Voltage</b> ESD protection transistor exists between V+ and ground.

■ **TYPICAL CHARACTERISTICS** ( $T_a=25^\circ\text{C}$ ,  $V_+ = 2.2\text{V}$ ,  $f_{rf} = 429\text{MHz}$ ,  $P_{rf} = -35\text{dBm}$ ,  $f_{lo} = 407.7\text{MHz}$ ,  $P_{lo} = -15\text{dBm}$ ,  $f_{if} = 21.3\text{MHz}$ , unless otherwise noted)

**Operating Current  $I_{ccq}$  versus Supply Voltage  $V_+$**

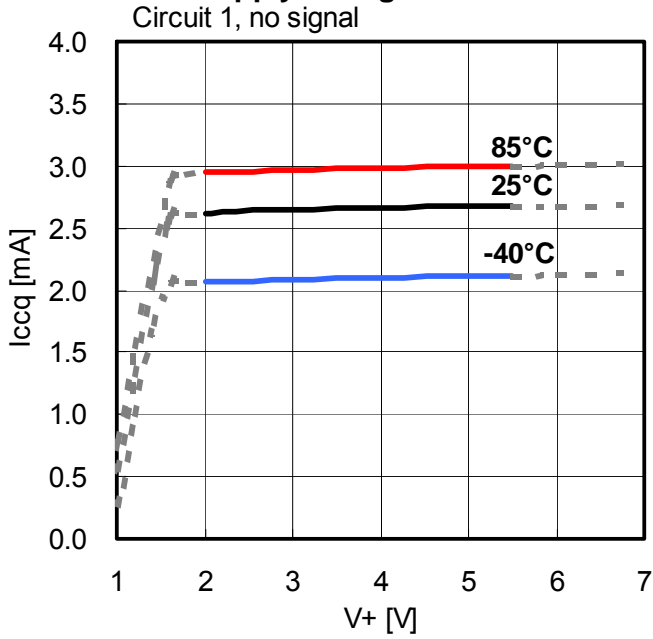

**Operating Current  $I_{ccq}$  versus Ambient Temperature  $T_a$**

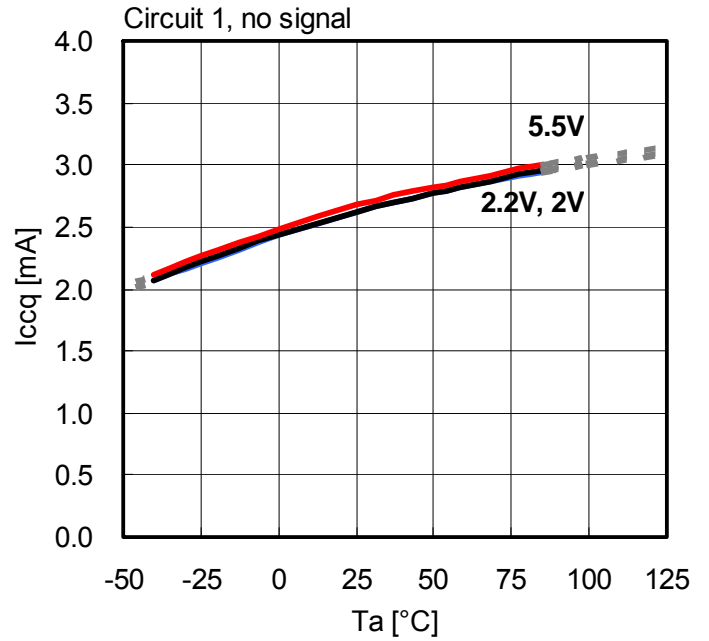

**Conversion Gain CG versus Supply Voltage  $V_+$**

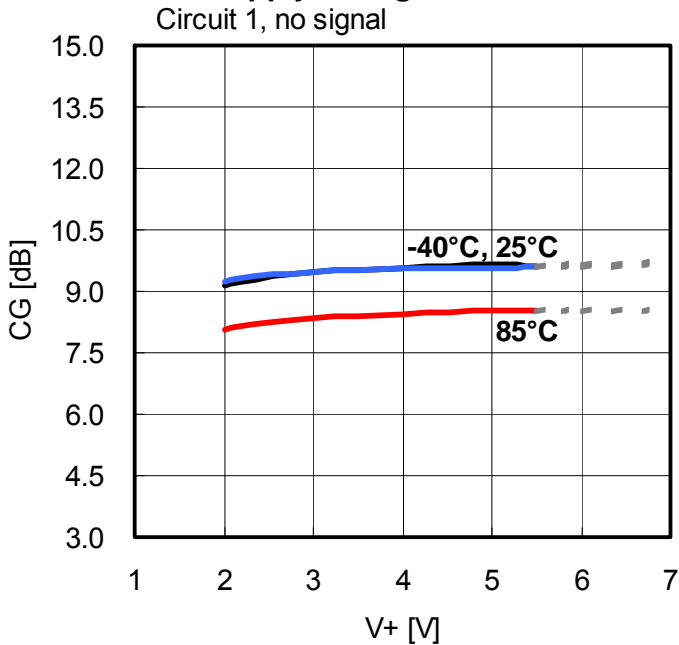

**Conversion Gain CG versus Ambient Temperature  $T_a$**

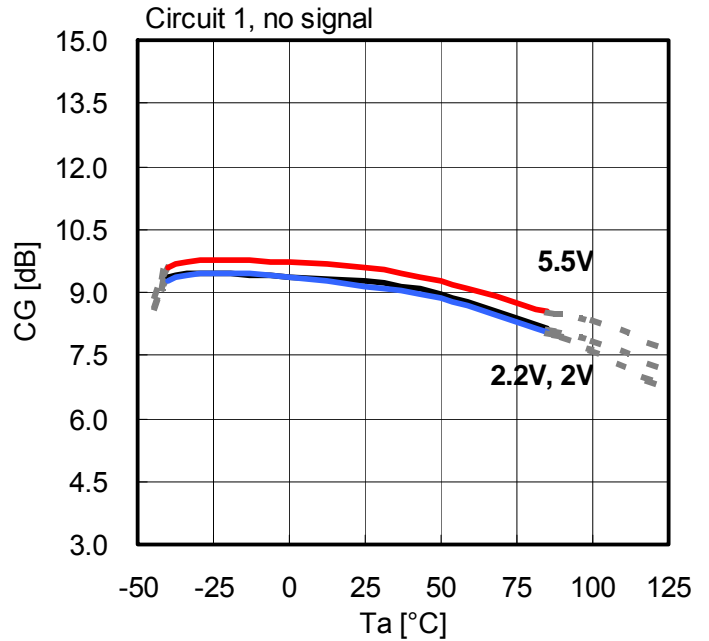

IF Output Level Pif versus RF Input Level Prf

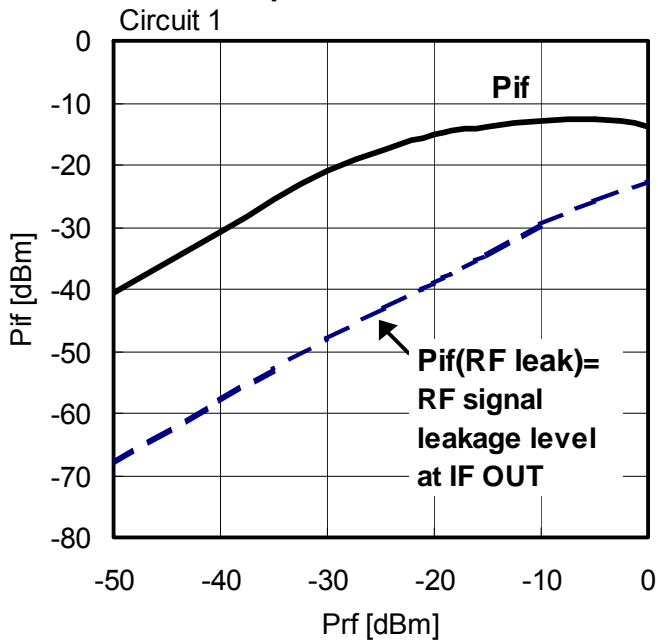

IF Output Level Pif versus Ambient Temperature Ta

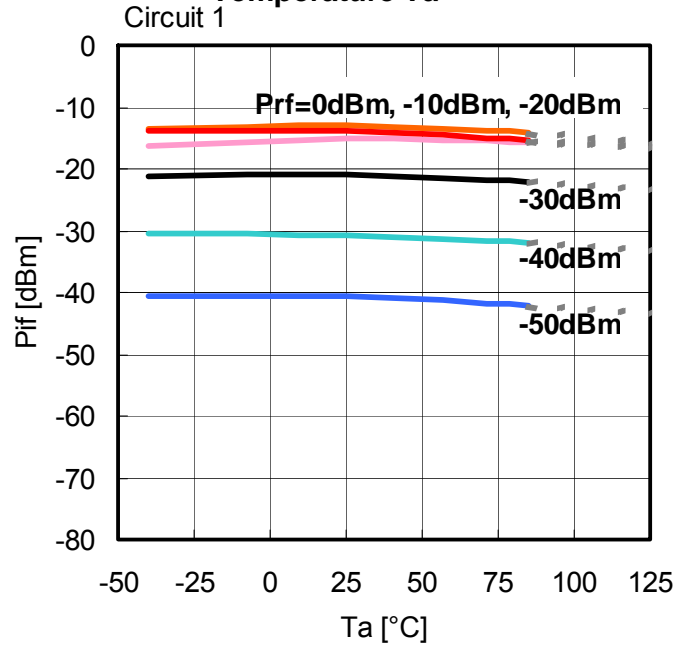

IF Output Level Pif versus LO IN Input level Plo

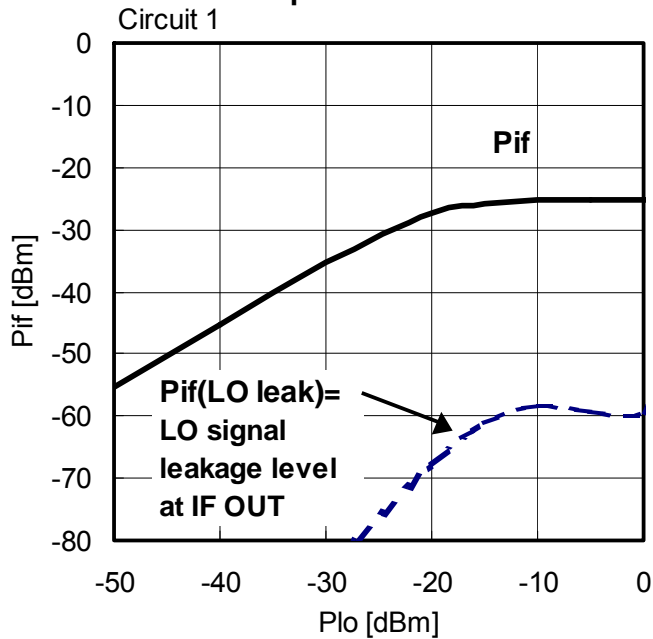

IF Output Level Pif versus Ambient Temperature Ta

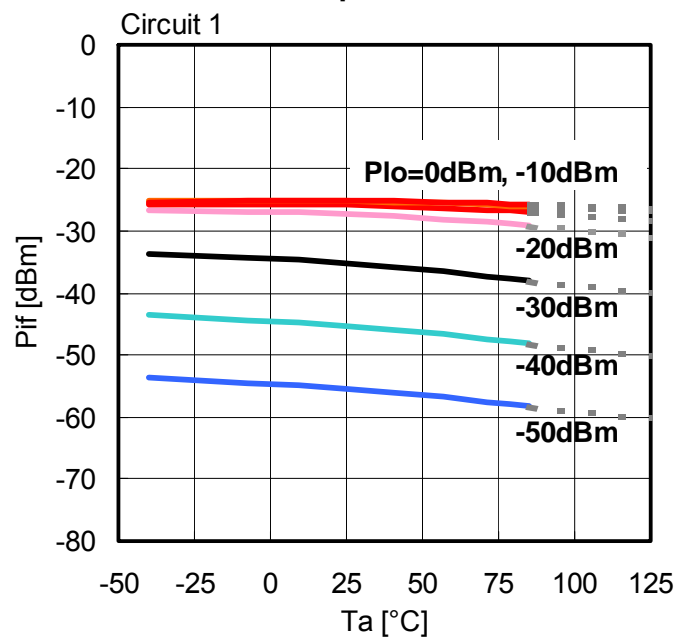



**Intermodulation versus  
RF Input Level Prf**

Circuit 1, frf1=429MHz, frf2=429.0125MHz,  
fif=21.3MHz

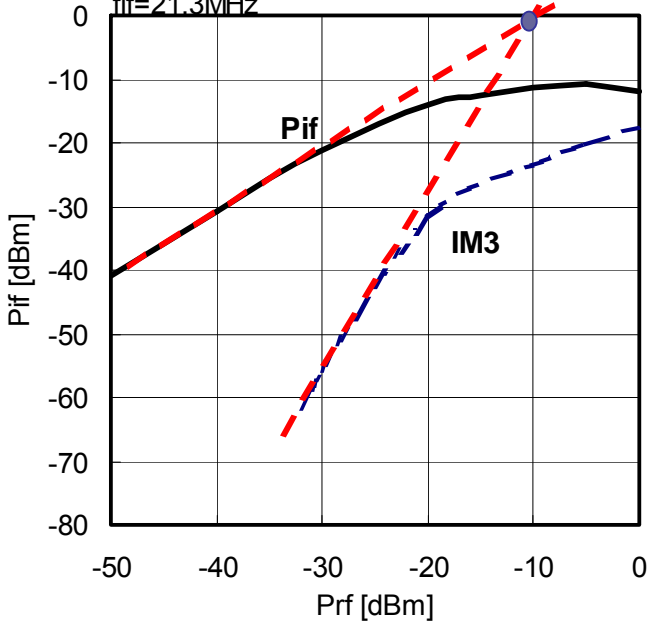

**IP3 versus Ambient Temperature Ta**

Circuit 1, frf1=429MHz, frf2=429.0125MHz,  
fif=21.3MHz

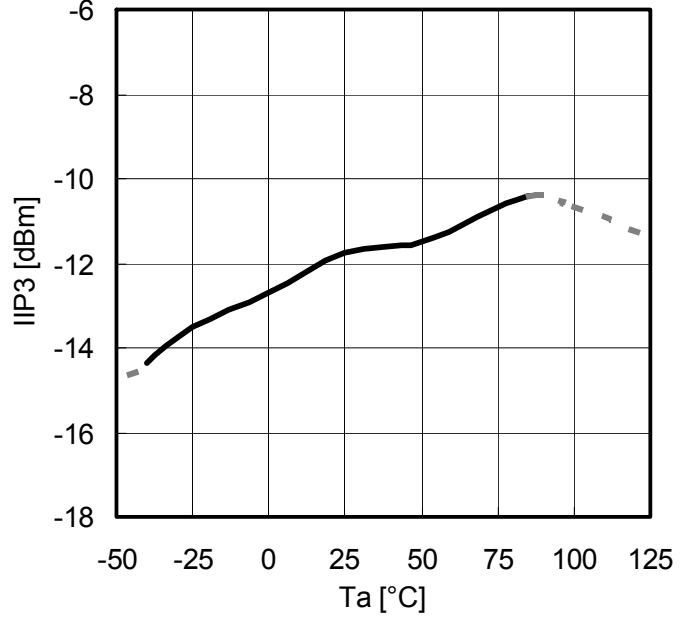

**Noise Figure NF versus  
Supply Voltage V+**

Circuit 2

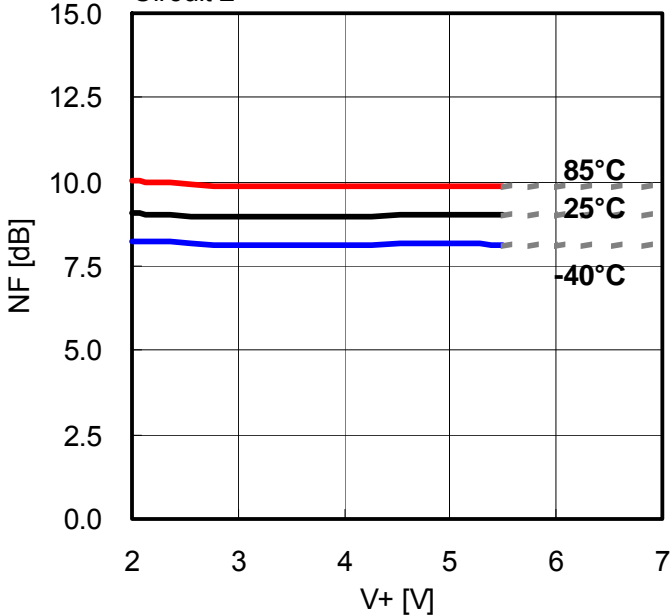

**Noise Figure NF versus  
Ambient Temperature Ta**

Circuit 2

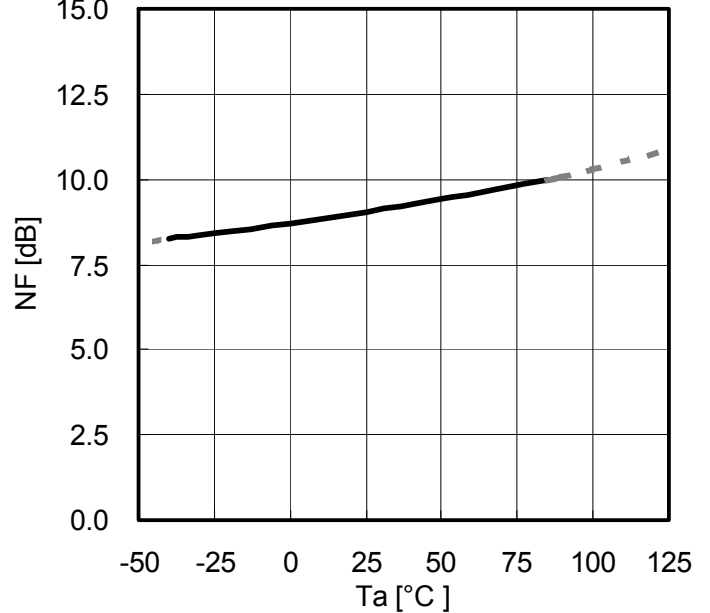

**Voltage Conversion Gain VCG versus  
RF Input Frequency frf**

Circuit 5, Prf=-35dBm, Plo=-15dBm,  
fif=21.3MHz

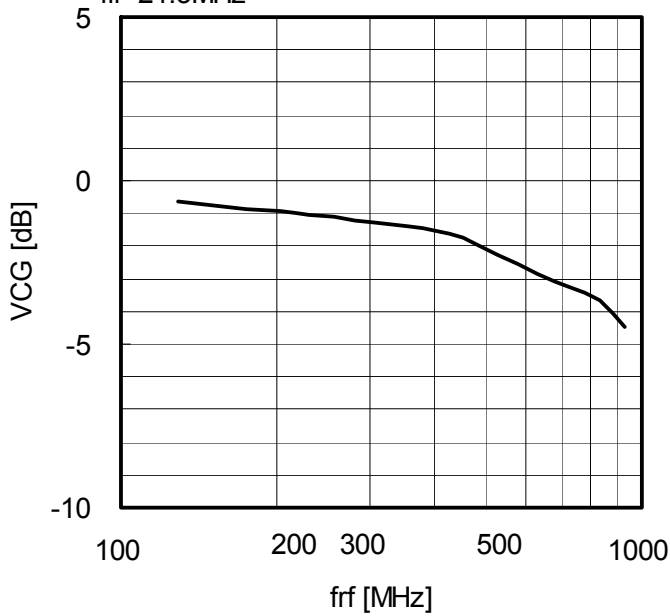

**RF IN Characteristics**  
Circuit 3

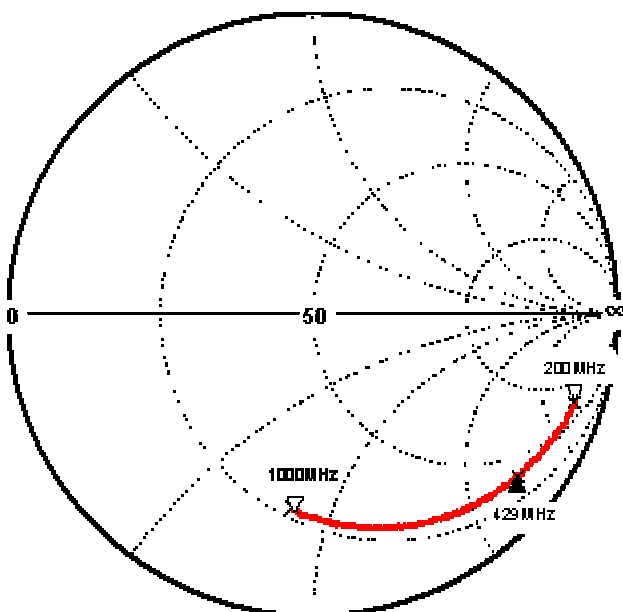

**LO IN Characteristics**  
Circuit 3

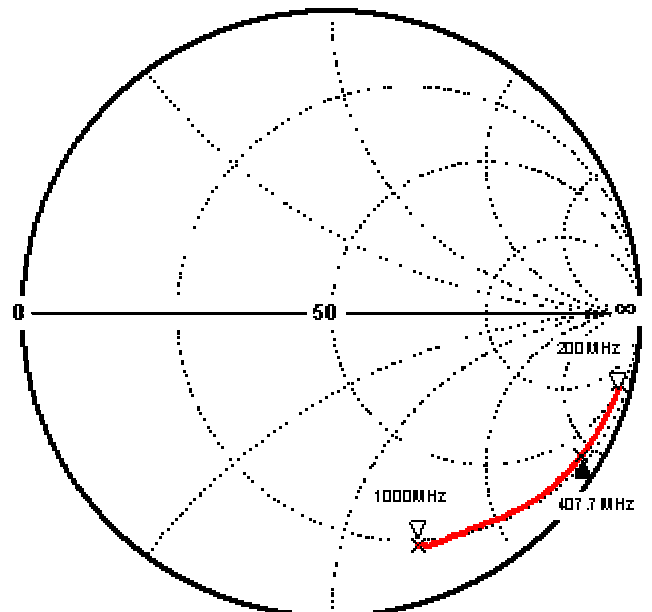

**[CAUTION]**

The specifications on this databook are only given for information, without any guarantee as regards either mistakes or omissions. The application circuits in this databook are described only to show representative usages of the product and not intended for the guarantee or permission of any right including the industrial rights.