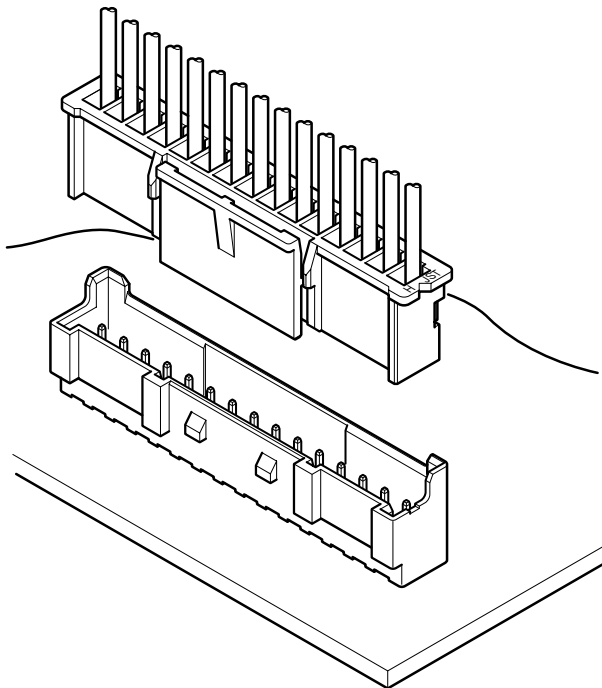

JST

Crimp

2.0mm
(.079") pitch

PA CONNECTOR

Disconnectable Crimp style connectors

Features

• **Locking device**

The housing has a locking device to securely hold the header, preventing accidental disconnection because of external forces that might result from the routing of wires during assembly process or of vibration.

• **Reliable contacts**

The box contact supplies stable contact performance even under conditions of vibration, distortion, low voltage or low current.

• **Low insertion force**

Header pins are reflow-treated, which provides low insertion force.

• **Insertion guide mechanism**

Header has housing insertion guides for easy and secure insertion.

• **Flanged press pin**

Top entry type header has flanged press pins, preventing accidental removal of the pins that might result from the distorted unmating especially in the case of small no. of circuits.

• **Polarizing boss**

Top entry type headers with polarizing bosses are also available.

Specifications

- Current rating: 3A AC, DC (AWG#22)
 - Voltage rating: 250V AC, DC
 - Temperature range: -25°C to +85°C
(including temperature rise in applying electrical current)
 - Relative humidity: 0 to 80%
 - Contact resistance: Initial value/10m Ω max.
After environmental testing/20m Ω max.
 - Insulation resistance: 1,000M Ω min.
 - Withstanding voltage: 800V AC/minute
 - Applicable wire: AWG #28 to #22
 - Applicable PC board thickness: 1.6mm(.063")
- * Contact JST for details.

PA CONNECTOR

Contact

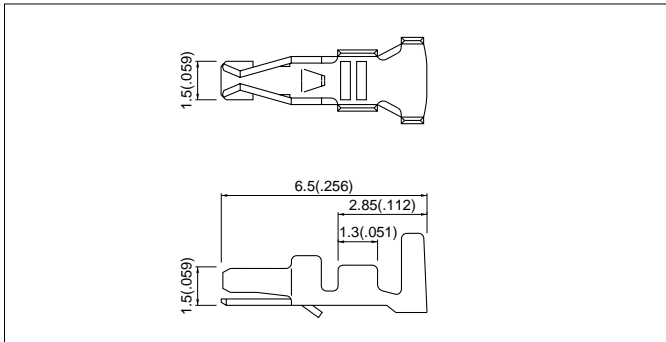

Model No.	Applicable wire			Q'ty / reel
	mm ²	AWG #	Insulation O.D. mm(in.)	
SPHD-002T-P0.5	0.08 to 0.21	28 to 24	0.9 to 1.5(.035 to .059)	8,000
SPHD-001T-P0.5	0.13 to 0.33	26 to 22	1.0 to 1.5(.039 to .059)	

Material and Finish

Phosphor bronze, tin-plated

Contacts are interchangeable with those of the PAD connector.

Housing

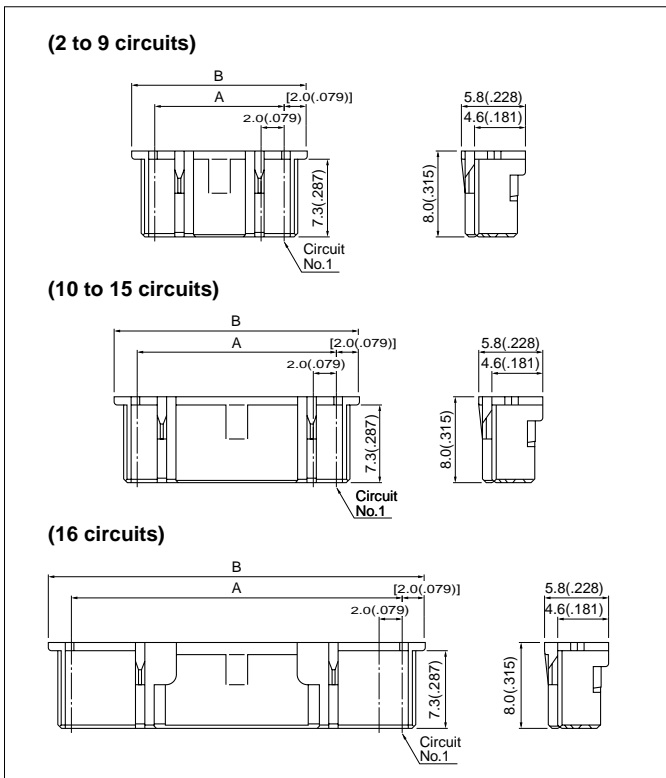

Circuits	Model No.	Dimensions mm(in.)		Q'ty / bag
		A	B	
2	PAP-02V-S	2.0 (.079)	6.0 (.236)	5,000
3	PAP-03V-S	4.0 (.157)	8.0 (.315)	5,000
4	PAP-04V-S	6.0 (.236)	10.0 (.394)	5,000
5	PAP-05V-S	8.0 (.315)	12.0 (.472)	5,000
6	PAP-06V-S	10.0 (.394)	14.0 (.551)	1,000
7	PAP-07V-S	12.0 (.472)	16.0 (.630)	1,000
8	PAP-08V-S	14.0 (.551)	18.0 (.709)	1,000
9	PAP-09V-S	16.0 (.630)	20.0 (.787)	1,000
10	PAP-10V-S	18.0 (.709)	22.0 (.866)	1,000
11	PAP-11V-S	20.0 (.787)	24.0 (.945)	1,000
12	PAP-12V-S	22.0 (.866)	26.0(1.024)	1,000
13	PAP-13V-S	24.0 (.945)	28.0(1.102)	1,000
14	PAP-14V-S	26.0(1.024)	30.0(1.181)	1,000
15	PAP-15V-S	28.0(1.102)	32.0(1.260)	1,000
16	PAP-16V-S	30.0(1.181)	34.0(1.339)	1,000

Material and Finish

Nylon66, UL94V-0, natural (white)

PA CONNECTOR

Shrouded header

Top entry type

(2 to 9 circuits)

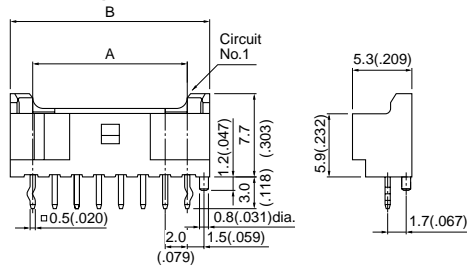

(10 to 15 circuits)

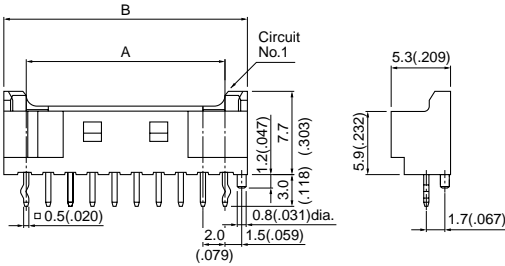

(16 circuits)

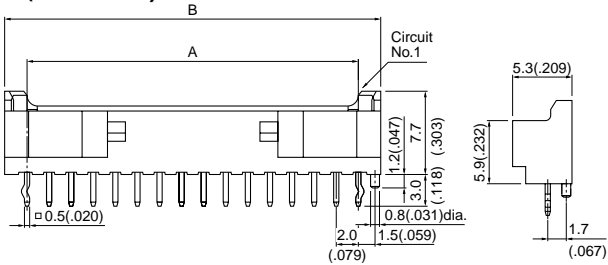

Circuits	Model No.		Dimensions mm(in.)		Q'ty / bag
	Without a boss	With a boss	A	B	
2 (Note1)	B02B-PAFYK-A	B02B-PAFYK-1A	2.0 (.079)	6.0 (.236)	1,000
2	B02B-PASK	B02B-PASK-1	2.0 (.079)	6.0 (.236)	1,000
3	B03B-PASK	B03B-PASK-1	4.0 (.157)	8.0 (.315)	1,000
4	B04B-PASK	B04B-PASK-1	6.0 (.236)	10.0 (.394)	1,000
5	B05B-PASK	B05B-PASK-1	8.0 (.315)	12.0 (.472)	500
6	B06B-PASK	B06B-PASK-1	10.0 (.394)	14.0 (.551)	500
7	B07B-PASK	B07B-PASK-1	12.0 (.472)	16.0 (.630)	500
8	B08B-PASK	B08B-PASK-1	14.0 (.551)	18.0 (.709)	500
9	B09B-PASK	B09B-PASK-1	16.0 (.630)	20.0 (.787)	500
10	B10B-PASK	B10B-PASK-1	18.0 (.709)	22.0 (.866)	500
11	B11B-PASK	B11B-PASK-1	20.0 (.787)	24.0 (.945)	250
12	B12B-PASK	B12B-PASK-1	22.0 (.866)	26.0 (1.024)	250
13	B13B-PASK	B13B-PASK-1	24.0 (.945)	28.0 (1.102)	250
14	B14B-PASK	B14B-PASK-1	26.0 (1.024)	30.0 (1.181)	250
15	B15B-PASK	B15B-PASK-1	28.0 (1.102)	32.0 (1.260)	250
16	B16B-PASK	B16B-PASK-1	30.0 (1.181)	34.0 (1.339)	250

Material

Post: Copper alloy, copper-undercoated, tin/lead-plated

Wafer: Glass-filled PBT, UL94V-0, natural (white)

(Note1) Nylon 66, UL94V-0, vivid yellow

Shrouded header

Side entry type

(2 to 9 circuits)

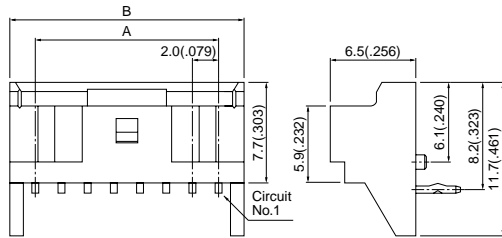

(10 to 15 circuits)

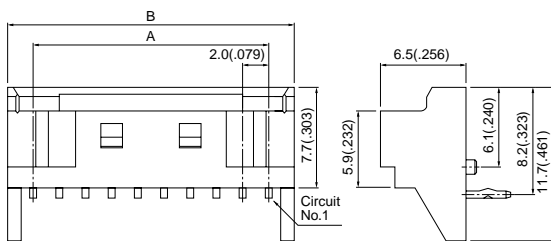

(16 circuits)

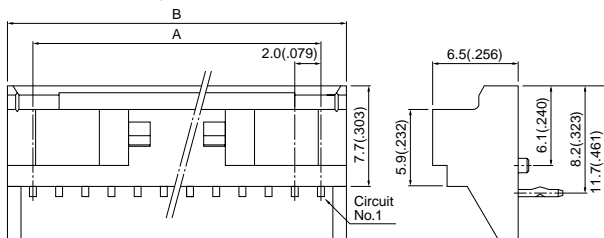

Circuits	Model No.	Dimensions mm(in.)		Qty / box
		A	B	
2	S02B-PASK-2	2.0 (.079)	6.0 (.236)	1,000
3	S03B-PASK-2	4.0 (.157)	8.0 (.315)	1,000
4	S04B-PASK-2	6.0 (.236)	10.0 (.394)	500
5	S05B-PASK-2	8.0 (.315)	12.0 (.472)	500
6	S06B-PASK-2	10.0 (.394)	14.0 (.551)	500
7	S07B-PASK-2	12.0 (.472)	16.0 (.630)	500
8	S08B-PASK-2	14.0 (.551)	18.0 (.709)	250
9	S09B-PASK-2	16.0 (.630)	20.0 (.787)	250
10	S10B-PASK-2	18.0 (.709)	22.0 (.866)	250
11	S11B-PASK-2	20.0 (.787)	24.0 (.945)	250
12	S12B-PASK-2	22.0 (.866)	26.0 (1.024)	250
13	S13B-PASK-2	24.0 (.945)	28.0 (1.102)	250
14	S14B-PASK-2	26.0 (1.024)	30.0 (1.181)	250
15	S15B-PASK-2	28.0 (1.102)	32.0 (1.260)	200
16	S16B-PASK-2	30.0 (1.181)	34.0 (1.339)	200

Material and Finish

Post: Copper alloy, copper-undercoated, tin/lead-plated
Wafer: Glass-filled PBT, UL94V-0, natural (white)

PC board layout (viewed from component side) and Assembly layout

Top entry type

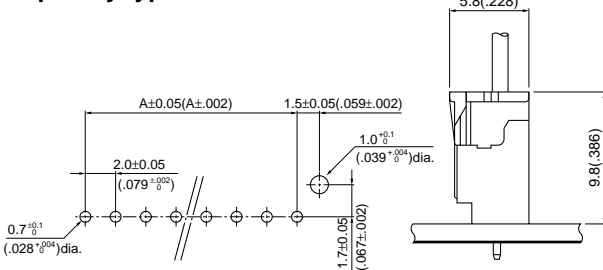

Side entry type

